

SPECIAL CHARACTERISTICS (IO 515)			
REPORT	SC	AREA	CRITICAL VALUE
01	⊙	E12	OPERATING FEATURES
02	⊙	E10	OPERATING FEATURES
03	⊙	E9	CABLE FIXATION

REPRESENTATIVE VIEW OF FIXING POINTS WITH STUD M5

REVISION HISTORY			
REV.	DESCRIPTION	NAME	DATE
0	FIRST ISSUE	M.LAGUARDIA	12.04.2016

REPRESENTATIVE VIEW - ASSEMBLY CONFIGURATIONS

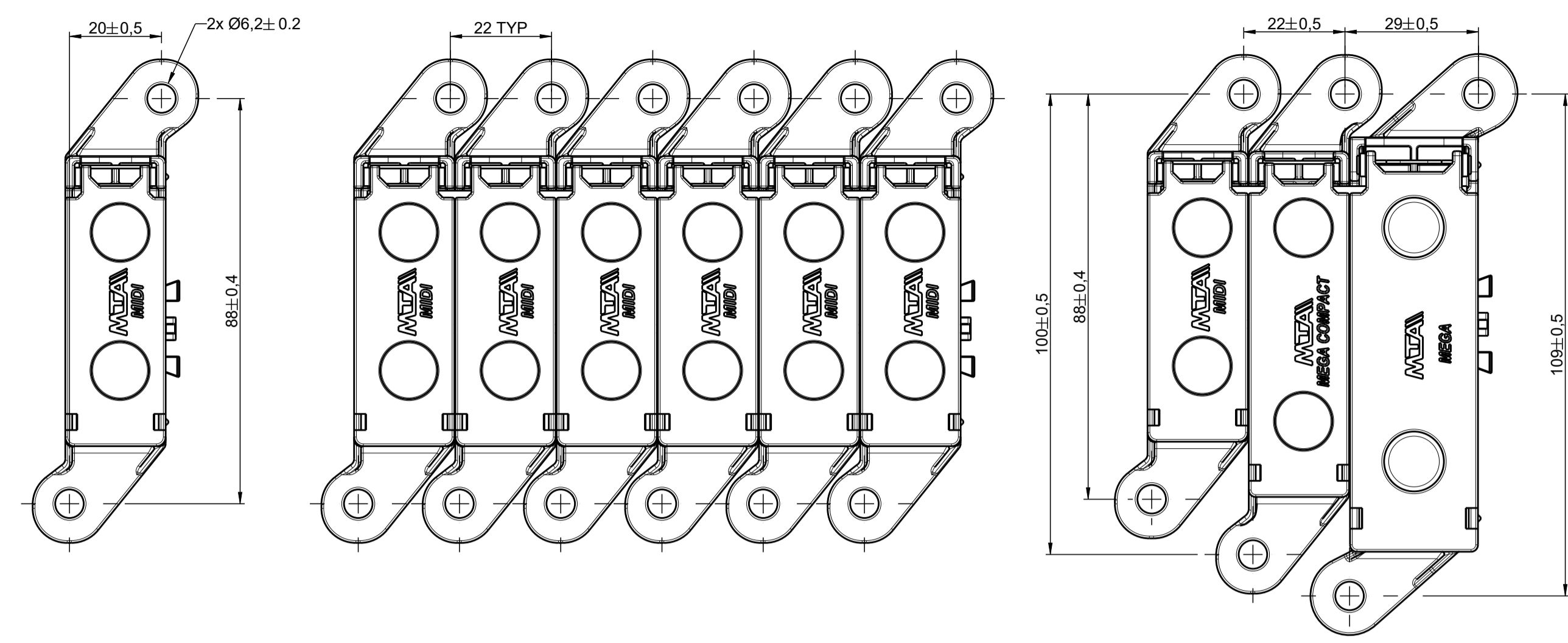
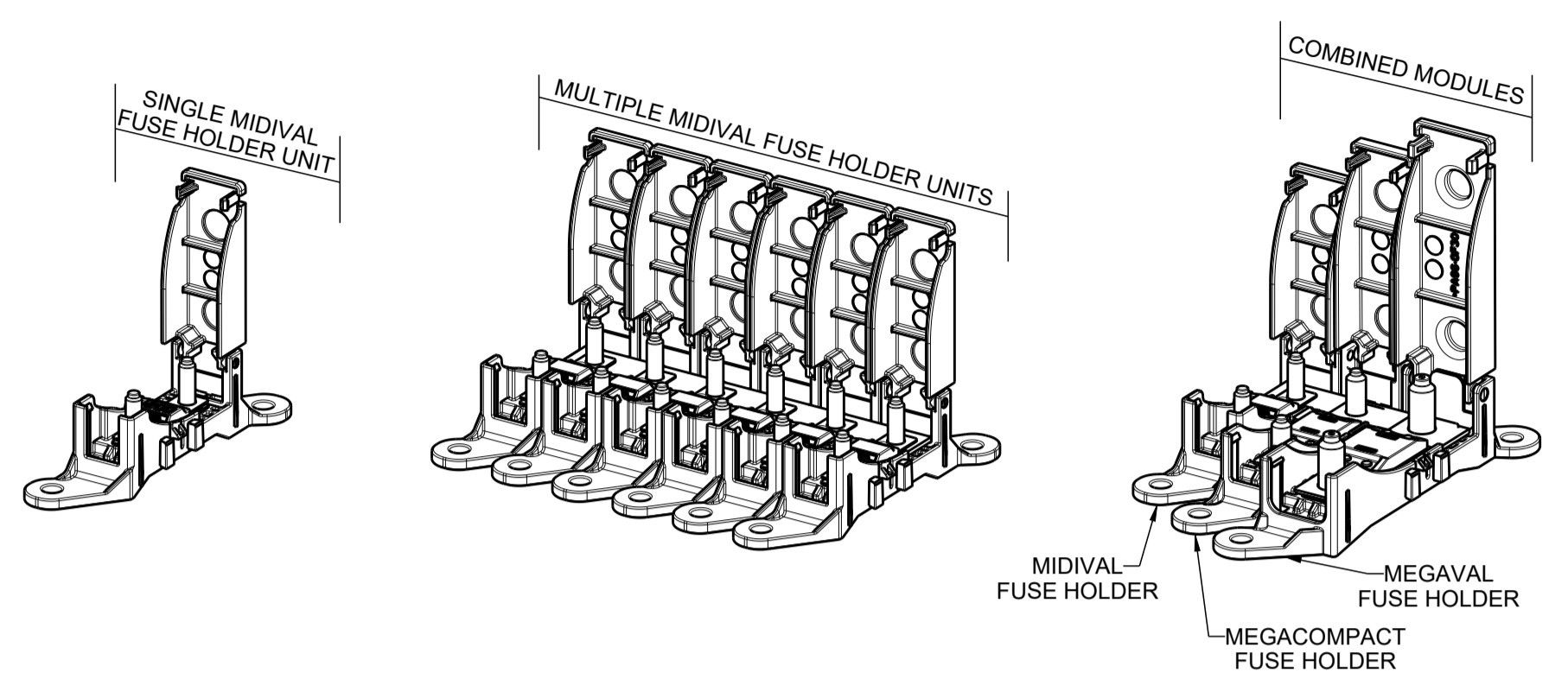

SCALE 1:2

MIVAL FUSE HOLDER WITH ASSEMBLED COVER - OVERALL DIMENSIONS COMPLIANT WITH ISO 8820-5:2015 SF30

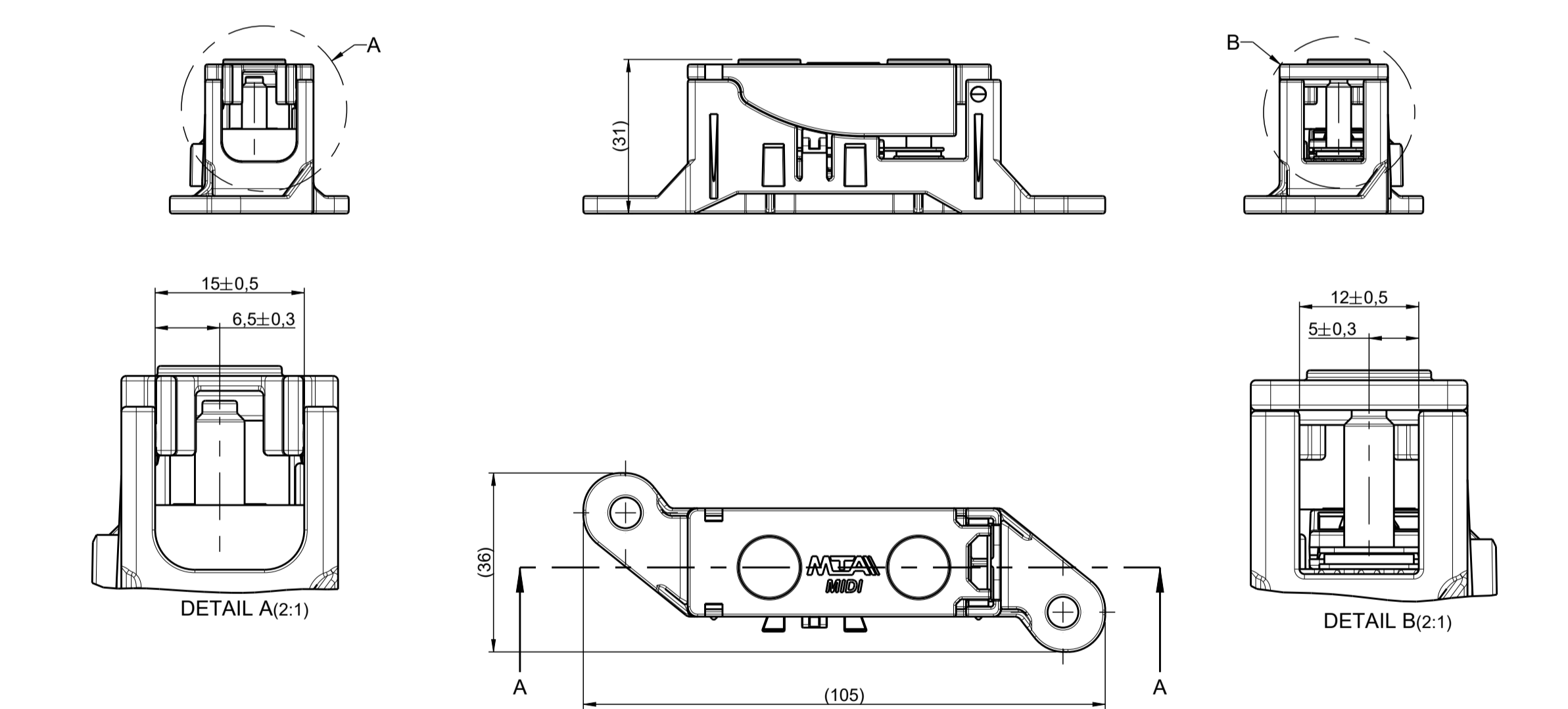
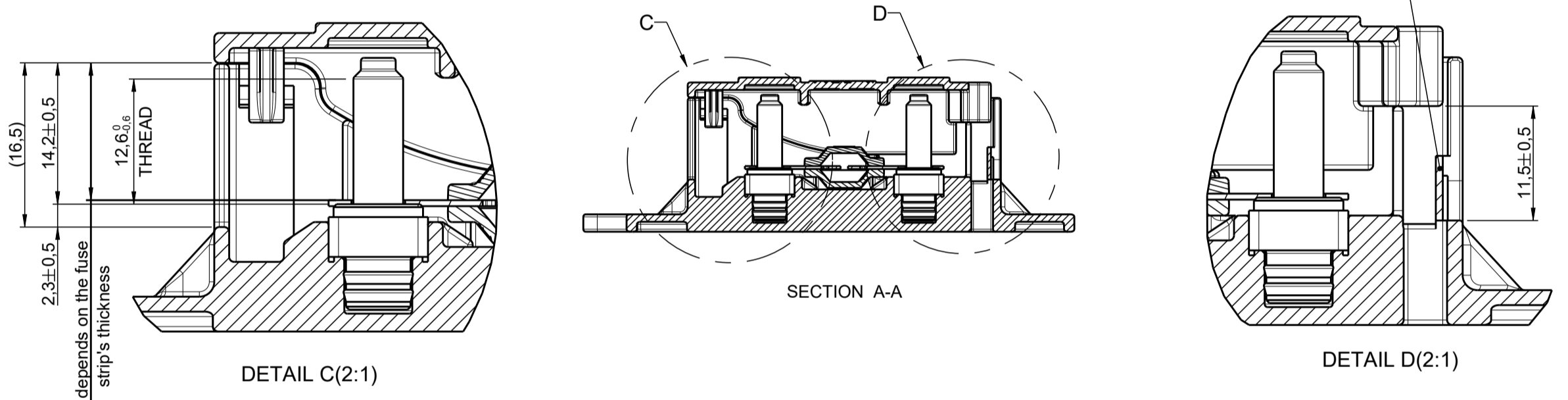

INSTALLATION

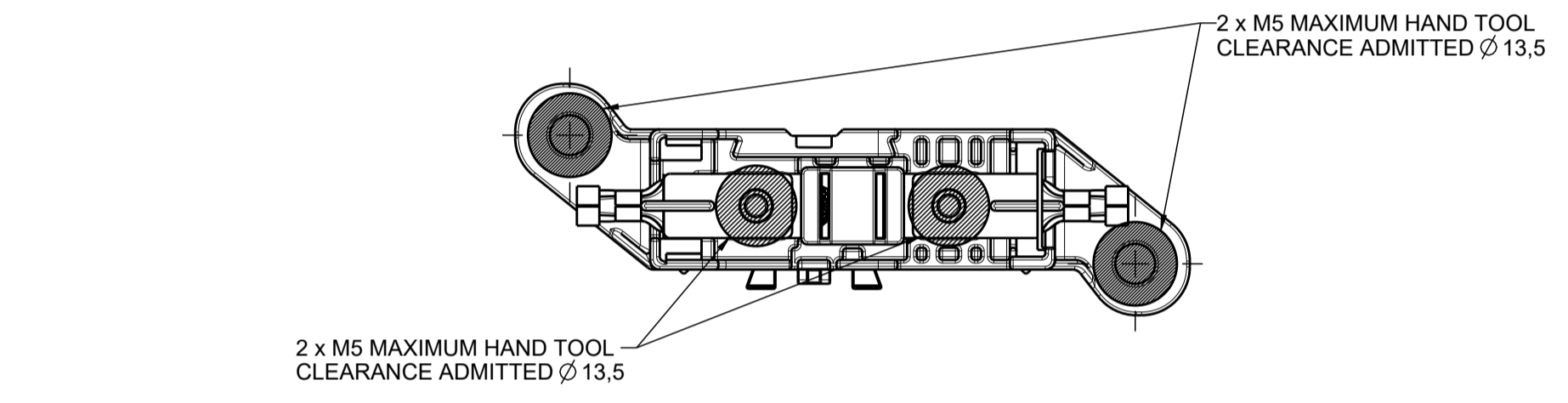

- USE TIE WRAPS / CLAMPS: HARNESS SHOULD BE SECURED FROM ANY MOVEMENT ONCE THE FUSE HOLDER IS INSTALLED (FOR BOTH INPUT AND OUTPUT CABLES).

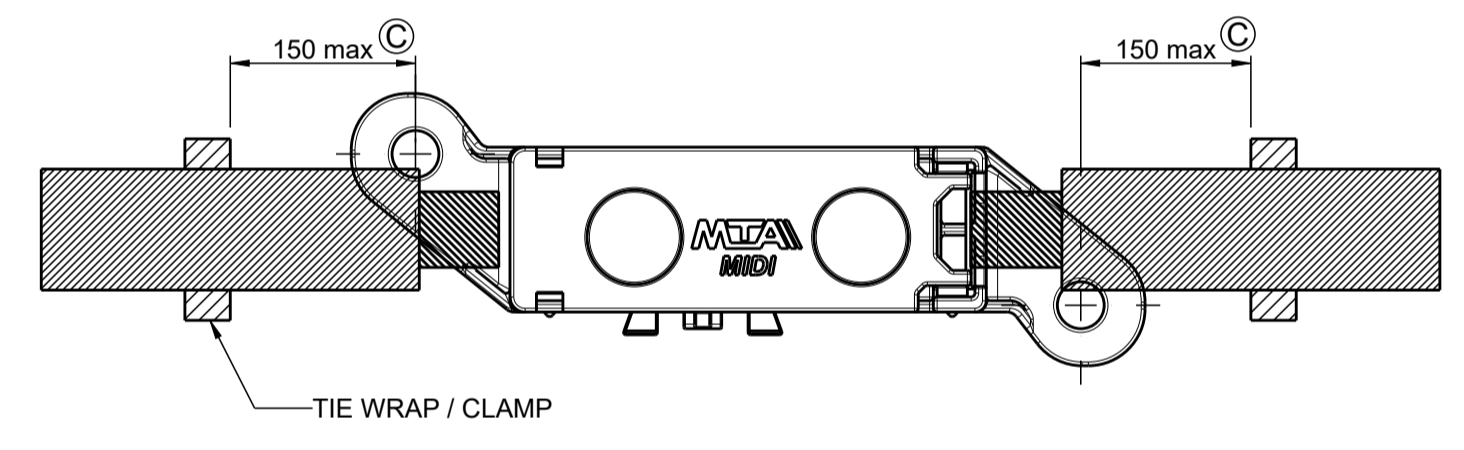

MTA M5 TERMINALS ASSOCIATED TABLE			
POS.	TERMINAL	MATERIAL	WIRE SECTION
A - B	1708240/xx	CuZn-Sn	2.5 + 4 sqmm
A - B	1708245/xx	CuZn-Sn	6 + 8 sqmm
A - B	1705606/xx	Cu-Sn	2.5 + 4 sqmm
A - B	1705705/xx	Cu-Sn	6 + 8 sqmm
A - B	1708250/xx	CuZn-Sn	10 + 16 sqmm
A - B	1705835/xx	Cu-Sn	10 + 20 sqmm
A - B	1605905/xx	Cu-Sn	25 + 35 sqmm

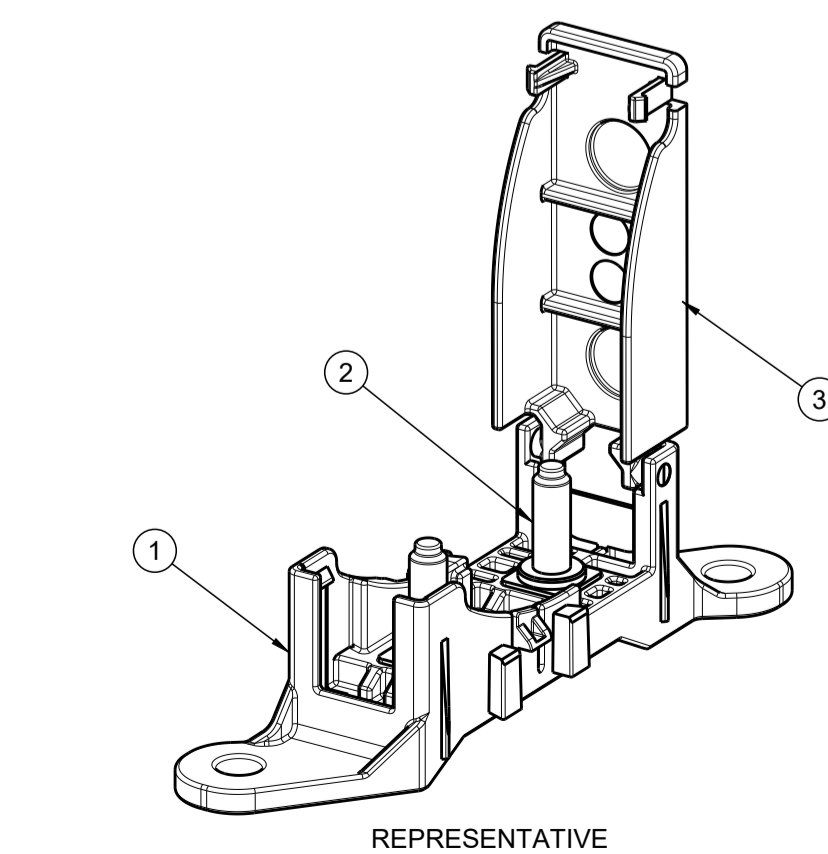
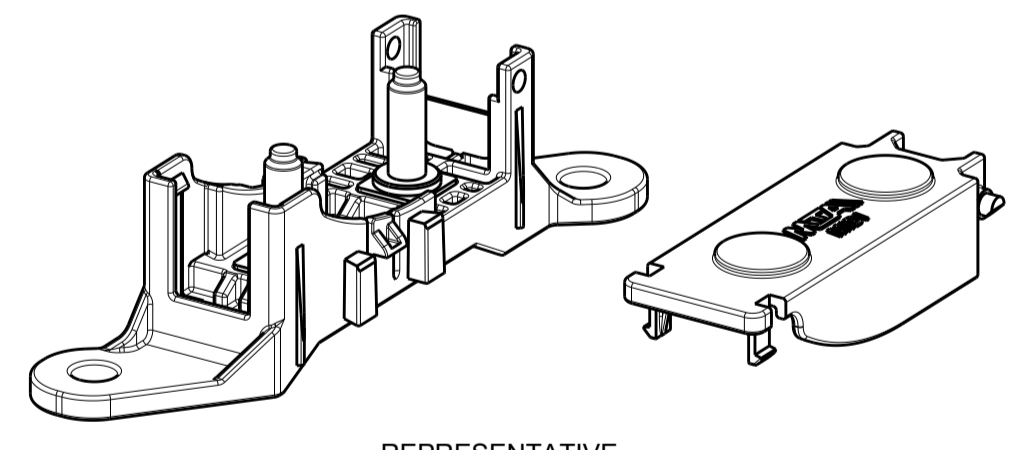
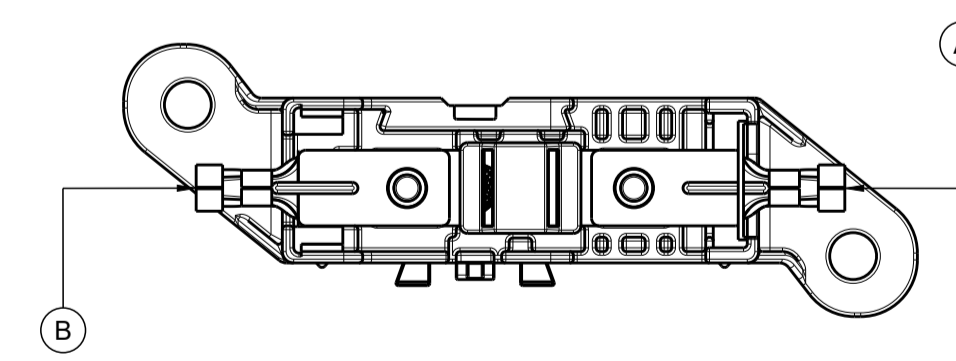

UNCONTROLLED COPY
In case of drawing updating/revision
NO AUTOMATIC
resubmission will follow

OPERATING FEATURES		
FEATURES	UNIT	VALUE
V MAX	V	32
I MAX	A	SEE ADDITIONAL NOTE (1)
TEMPERATURE RANGE	°C	SEE ADDITIONAL NOTE (2)
VIBRATION CLASS	-	SEE ADDITIONAL NOTE (3)
IP	IEC 529	20
FLAMMABILITY	UL 94	HB
	FMVSS 302	<= 100 mm/min
FUSE AND TERMINAL TIGHTENING TORQUE M5	Nm	4.5 ± 1
TIGHTENING TORQUE M5 FIXING POINTS	Nm	3.5 +/- 10%

ADDITIONAL NOTE:
1) ACCORDING TO FUSE DERATING CURVE DVP_1600017_rev.1 (C)
2) CONTINUOUS OPERATING TEMPERATURE RANGE: -40°C + +125°C (Overheating + T. Amb.)
NOT OPERATING MAX TEMPERATURE: 160°C (Short period condition)
3) COMPONENT DESIGNED TO OPERATE ENGINE COMPARTMENT (WHEELED VEHICLES)
4) NOT COMPLIANT TO CORROSIVE INDUSTRIAL ATMOSPHERE

IMPORTANT NOTE
1) CONSIDERING ALL POSSIBLE CONFIGURATIONS, IN ANY CASE, THE INSTALLER SHOULD TEST THE APPLICATION TO VERIFY THE PRODUCT MEETS THE CUSTOMER'S EXPECTATIONS.
2) IN CASE OF SINGLE MODULE APPLICATION THE COVER WILL BE IN THE SAME PACKAGE BUT NOT ASSEMBLED.
3) IN CASE OF COMBINED OR MULTIPLE CONFIGURATIONS THE COVER STATE OF SUPPLY WILL BE CHOSEN ACCORDING TO THE CUSTOMER'S NEEDS (ASSEMBLED OR NOT).
4) ASSOCIATED TERMINALS ARE DESCRIBED IN THE TABLE BELOW.
5) IN CASE OF COMBINED MULTIFUSE SEE ALSO: MEGACOMPACT FUSE HOLDER DRAWING 0301497/xx MEGAVAL FUSE HOLDER DRAWING 0301498/xx.
6) FOR THE CORRECT ASSEMBLY MUST BE USED SELF LOCKING NUT M5. STUDYING THE MAXIMUM HEIGHT OF THE NUTS ACCORDING TO TERMINAL HEIGHT TO GUARANTEE MINIMUM TWO THREADS AFTER THE ASSEMBLY.
7) THERE IS A POSSIBILITY THAT THE TERMINAL AREA IS EXPOSED, IT CAN BE COVERED BY A THERMO-SHRINKING SHEATH.
8) IT IS SUGGESTED TO SCRAP THE FALLEN PIECES.

3	1	COVER	PA66-GF30 (BLACK)
2	2	SCREW M5	STEEL CL. 8.8 - ZnNi
1	1	BODY	PA66-GF30 (BLACK)

POS.	Q.TY	DENOMINATION	MATERIAL
		MTA P/N 0301499/0x	Denom. MIVAL FUSE HOLDER
		Draw No. 16017M-00A	Used for -
		CLIENT	Material SEE TABLE
		Scale Weight(g) Lin.Tol.± Ang.Tol.±	Coating SEE TABLE
		1:1 35 0.5 1	Colour SEE TABLE
		Dimensions (in mm)	Note ACCORDING TO DVP 1600017_REV.1
		1/1	

REV 0 All proprietary rights reserved by MTA S.p.A. - This drawing shall not be reproduced, or in any way utilized, for the manufacture of the component or unit herein illustrated and must not be released to other parties, without written consent. Any infringement will be legally pursued.