

Wireless-Tag WT51822-S2

Bluetooth Low Energy 4.0 Module DATASHEET

Description

Bluetooth Low Energy® (BLE) module of WT51822-S2 is the next generation BLE module released by Wireless-Tag technology. The modules use nRF51822-QFAA from NORDIC as the controller chips. Given its small size, low power and competitive cost, WT51822-S2 can be easily used in your system and expedite your design.

nRF51822-QFAA is an ultra-low power 2.4 GHz wireless System on Chip (SoC) integrating the nRF51822 series 2.4 GHz transceiver, a 32 bit ARM® Cortex™-M0 CPU, flash memory, and analog and digital peripherals. nRF51822 can support Bluetooth® low energy and a range of proprietary 2.4 GHz protocols, such as Gazell from Nordic Semiconductor.

Fully qualified Bluetooth low energy stacks for nRF51822 are implemented in the S100 series of SoftDevices. The S100 series of SoftDevices are available for free and can be downloaded and installed on nRF51822 independent of your own application code.

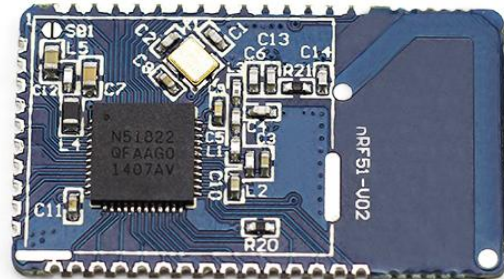

Features

- Operating temperature: -25°C ~75°C, typical 25°C
- 2.4 GHz transceiver
 - -93 dBm sensitivity in Bluetooth® low energy mode
 - 250 kbps, 1 Mbps, 2 Mbps supported data rates
 - TX Power -20 to +4 dBm in 4 dB steps
 - TX Power -30 dBm Whisper mode
 - 13 mA peak RX, 10.5 mA peak TX (0 dBm)
 - RSSI (1 dB resolution)
- ARM® Cortex™-M0 32 bit processor
 - 275 μ A/MHz running from flash memory
 - 150 μ A/MHz running from RAM
 - Serial Wire Debug (SWD)
- Memory
 - 256 KB embedded flash program memory
 - 16 KB RAM
- Flexible Power Management
 - Supply voltage range 2.0 V to 3.6 V
 - 2.5 μ s wake-up using 16 MHz RCOSC
 - 0.4 μ A @3V OFF mode
 - 0.5 μ A @3V in OFF mode + 1 region RAM retention

- 2.3 ^A @3V ON mode, all blocks IDLE
- 8/9/10 bit ADC - 8 configurable channels
- 31 General Purpose I/O Pins
- One 32 bit and two 16 bit timers with counter mode
- SPI Master
- UART (CTS/RTS)
- Two-wire Master (I2C compatible)
- Quadrature Decoder (QDEC)
- AES HW encryption
- Real Timer Counter (RTC)
- 16 MHz crystal
- Balun
- AES HW encryption
- Package variants
- Operating distance: 0~45m, class II level
- Support System: IOS & Android
- WT51822-S2, 16.5 x 28.8 mm, with PCB antenna.

Applications

- Computer peripherals and I/O devices
- Mouse
- Keyboard
- Multi-touch track pad
- Interactive entertainment devices
- Remote control
- 3D Glasses
- Gaming controller
- Personal Area Networks
- Health/fitness sensor and monitor devices
- Medical devices
- Key-fobs + wrist watch
- Remote control toys

1. Mechanical Data

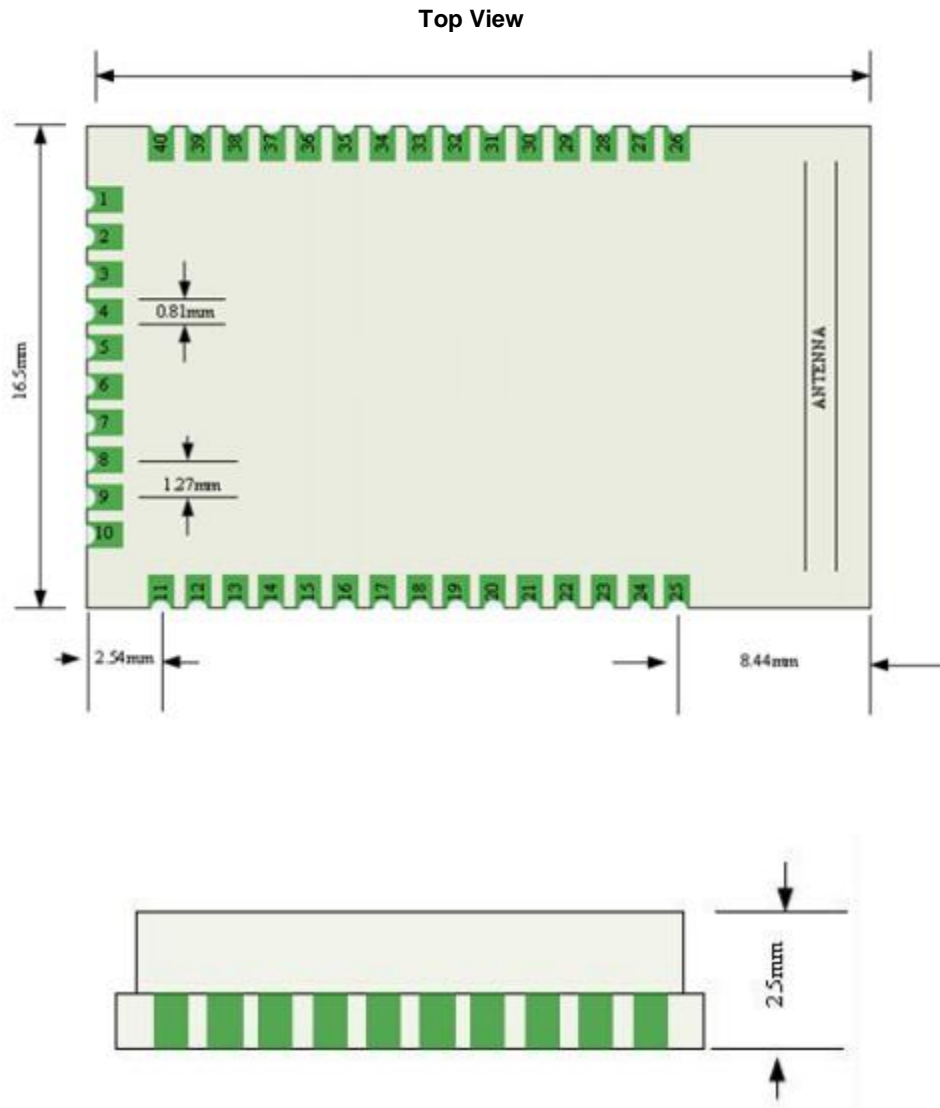

2. Pin Functions

No.	Name	Function description	No.	Name	Function description
1	VCC	DC2.0 V~3.6V	21	SWDIO RST	System reset (active low). Also HW debug and flash programming I/O
2	P0.30	General purpose I/O pin	22	SWDCLK	HW debug and flash programming I/O
3	P0.00	General purpose I/O pin	23	P0.17	General purpose I/O pin

	AREF0	ADC Reference voltage			
4	P0.01 AIN2	General purpose I/O pin ADC input 2	24	P0.18	General purpose I/O pin
5	P0.02 AIN3	General purpose I/O pin ADC input 3	25	P0.19	General purpose I/O pin
6	P0.03 AIN4	General purpose I/O pin ADC input 4	26	P0.20	General purpose I/O pin
7	P0.04 AIN5	General purpose I/O pin ADC input 5	27	GND	Ground (0 V)
8	P0.05 AIN6	General purpose I/O pin ADC input 6	28	ANTEN (GND)	2.4G antenna (Ground (0 V))*
9	P0.06 AIN7 AREF1	General purpose I/O pin ADC input 7 ADC Reference voltage	29	GND	Ground (0 V)
10	P0.07	General purpose I/O pin	30	GND	Ground (0 V)
11	GND	Ground (0 V)	31	GND	Ground (0 V)
12	P0.08	General purpose I/O pin	32	P0.21	General purpose I/O pin
13	P0.09	General purpose I/O pin	33	P0.22	General purpose I/O pin
14	P0.10	General purpose I/O pin	34	P0.23	General purpose I/O pin
15	P0.11	General purpose I/O pin	35	P0.24	General purpose I/O pin
16	P0.12	General purpose I/O pin	36	P0.25	General purpose I/O pin
17	P0.13	General purpose I/O pin	37	P0.26 AIN0 XL2	General purpose I/O pin ADC input 0 Connection for 32.768 kHz crystal
18	P0.14	General purpose I/O pin	38	P0.27 AIN1 XL1	General purpose I/O pin ADC input 1 Connection for 32.768 kHz crystal or external 32.768 kHz clock reference
19	P0.15	General purpose I/O pin	39	P0.28	General purpose I/O pin
20	P0.16	General purpose I/O pin	40	P0.29	General purpose I/O pin

3. Schematics

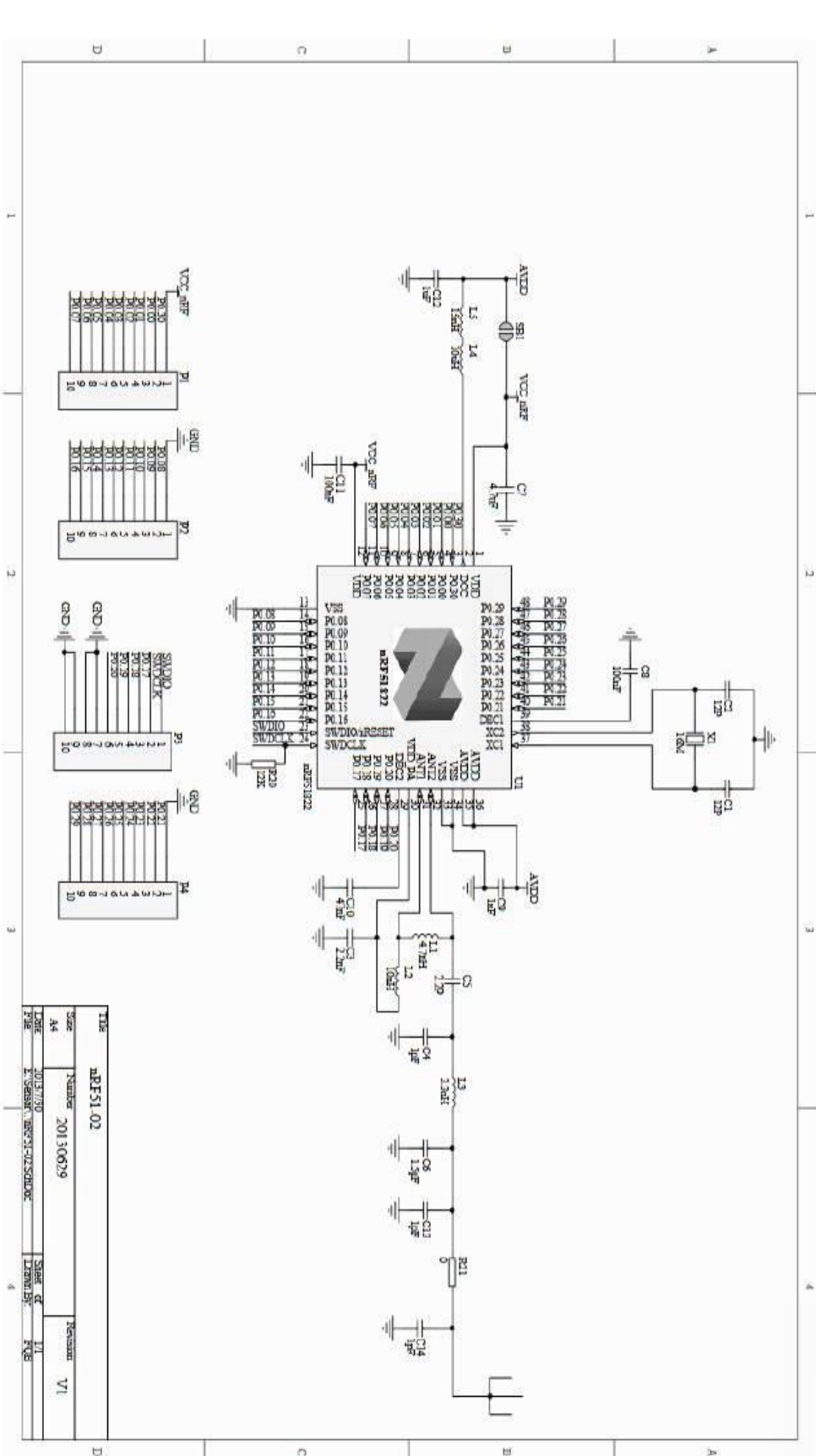

4. Physical drawings

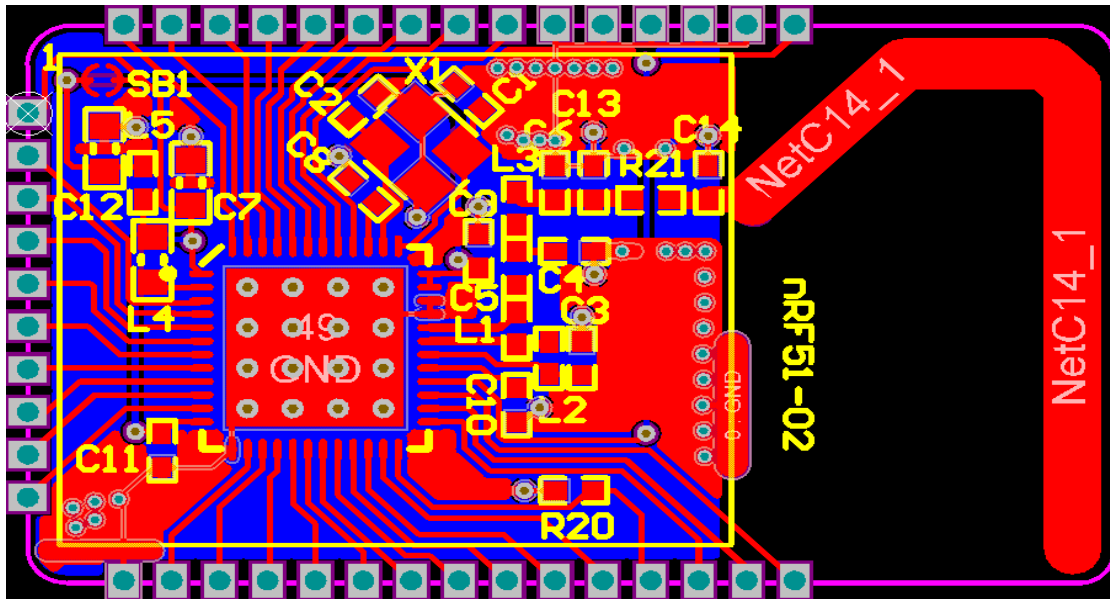

5. Reflow soldering reference

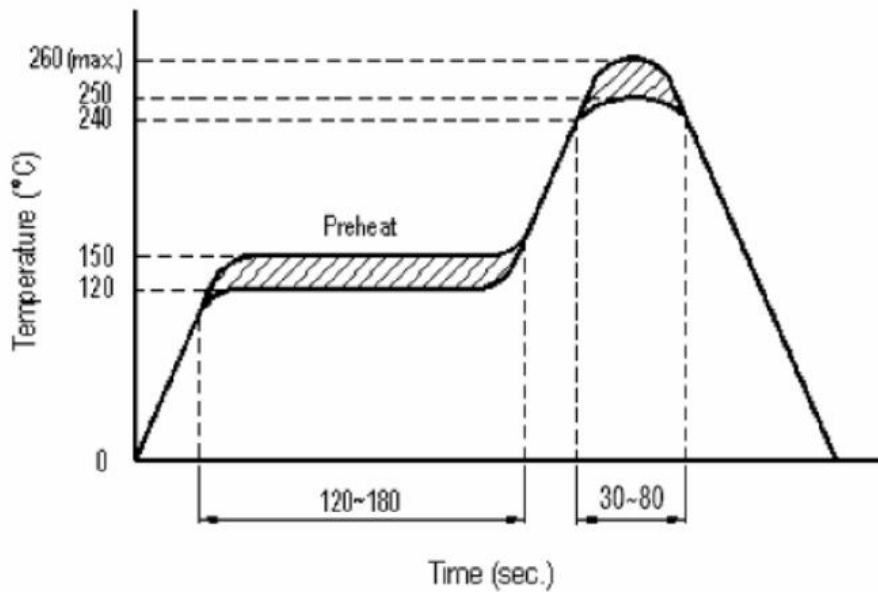

6. Technical Support

For technical support, please send e-mail to: technical@wireless-tag.com

Disclaimer: We reserve the final interpretation and modification rights to update the product manuals without notice at any time!