

3-PHASE AC Motor Controller IC

Features

- Floating channel up to +1200V
- “soft” over-current shutdown turns off output
- Integrated desaturation circuit
- Two stage turn on output for di/dt control
- Integrated brake IGBT driver with protection
- Voltage feedback sensing function
- Separate pull-up/pull-down output drive pins
- Matched delay outputs
- Under voltage lockout with hysteresis band
- Programmable deadtime
- Hard shutdown function

Description

The IR2238Q is a high voltage, 3-phase IGBT driver best suited for AC motor drive applications. Integrated desaturation logic provides all mode of overcurrent protection, including ground fault protection. Soft shutdown is predominantly initiated in the event of overcurrent followed by turn-off of all six outputs. A shutdown input is provided for a customized shutdown function. The DT pin allows external resistor to program the deadtime. Output drivers have separate turn on/off pins with two stage turn-on output to achieve the desired di/dt switching level of IGBT. Voltage feedback provides accurate volts *seconds measurement.

Product Summary

| | |
|---|---------------|
| V_{OFFSET} | 1200V max. |
| $I_{O+/-}$ (min.) | 220mA/460mA |
| V_{OUT} | 12.5V - 20V |
| Brake ($I_{O+/-}$ min) | 40mA/80mA |
| Deadtime Asymmetry Skew (max.) | 145nsec |
| Deadtime (typ. with $R_{DT}=39k\Omega$) | 1 μ sec |
| DESAT Blanking time (typ.) | 3.0 μ sec |
| DSH, DSL input voltage threshold (typ.) | 8.0V |
| Soft shutdown duration time (typ.) | 6.0 μ sec |
| Voltage feedback matching delay time (max.) | 125nsec |

Package

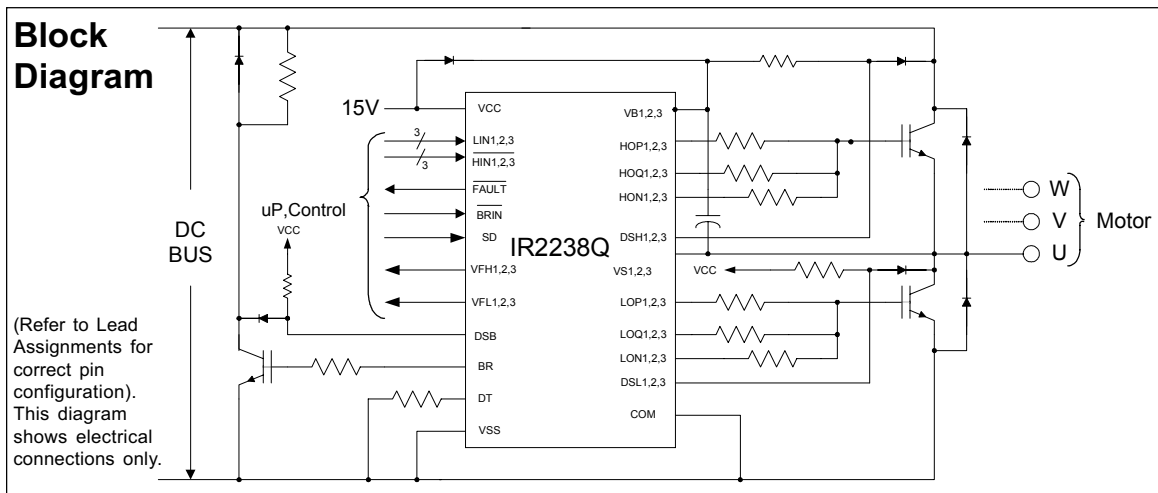
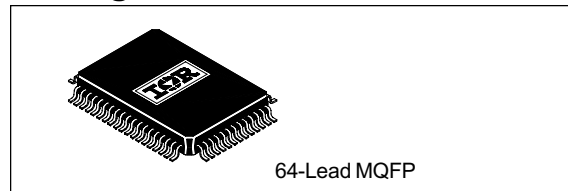

Absolute Maximum Ratings (tentative)

Absolute maximum ratings indicate sustained limits beyond which damage to the device may occur. All voltage parameters are absolute voltages referenced to COM, all currents are defined positive into any lead. The thermal resistance and power dissipation ratings are measured under board mounted and still air conditions.

| Symbol | Definition | Min. | Max. | Units | |
|---------------------|--|---------------------------|---|-------|------|
| V _S | High side offset voltage | V _{B1,2,3} -25 | V _{B1,2,3} +0.3 | V | |
| V _B | High side floating supply voltage | -0.3 | 1225 | | |
| V _{HO} | High side floating output voltage (HOP, HON, HOQ) | V _{S1,2,3} - 0.3 | V _{B1,2,3} + 0.3 | | |
| V _{CC} | Low side and logic fixed supply voltage | -0.3 | 25 | | |
| V _{SS} | Logic ground | V _{CC} - 25 | V _{CC} + 0.3 | | |
| V _{LO} | Low side output voltage (LOP, LON, LOQ) | -0.3 | V _{CC} + 0.3 | | |
| V _{IN} | Logic input voltage (HIN/N,LIN, BRIN/N, SD) | V _{SS} - 0.3 | V _{CC} + 0.3 or V _{SS} + 15 which ever is lower | | |
| V _{FLT} | FAULT output voltage | V _{SS} - 0.3 | V _{CC} + 0.3 | | |
| V _F | Feedback output voltage | V _{SS} - 0.3 | V _{CC} + 0.3 | | |
| V _{DSH} | High side desat/feedback input voltage | V _{S1,2,3} - 0.3 | V _{B1,2,3} + 0.3 | | |
| V _{DSL} | Low side desat/feedback input voltage | - 0.3 | V _{CC} + 0.3 | | |
| V _{BR} | Brake output voltage | -0.3 | V _{CC} + 0.3 | | |
| dV _S /dt | Allowable offset voltage slew rate | — | 50 | | V/ns |
| P _D | Package power dissipation @ T _A ≤ +25°C | — | 2.0 | | W |
| R _{thJA} | Thermal resistance, junction to ambient | — | 60 | °C/W | |
| T _J | Junction temperature | — | 125 | °C | |
| T _S | Storage temperature | -55 | 150 | | |
| T _L | Lead temperature (soldering, 10 seconds) | — | 300 | | |

Recommended Operating Conditions

For proper operation the device should be used within the recommended conditions. All voltage parameters are absolute voltages referenced to COM. The V_S offset rating is tested with all supplies biased at 15V differential.

| Symbol | Definition | Min. | Max. | Units |
|----------------------|--|---------------------------|--------------------------|-------|
| V _{B1,2,3} | High side floating supply voltage | V _{S1,2,3} + 13 | V _{S1,2,3} + 20 | V |
| V _{S1,2,3} | High side floating supply offset voltage | Note 1 | 1200 | |
| V _{HO1,2,3} | High side (HOP/HOQ/HON) output voltage | V _{S1,2,3} | V _{B1,2,3} | |
| V _{LO1,2,3} | Low side (LOP/LOQ/LON) output voltage | V _{COM} | V _{CC} | |
| V _{IN} | Logic input voltage (HIN/N,LIN, BRIN/N SD) | V _{SS} | V _{SS} + 5 | |
| V _{CC} | Low side supply voltage | 12.5 | 20 | |
| V _{SS} | Logic ground | -5 | +5 | |
| V _{FLT} | FAULT output voltage | V _{SS} | V _{CC} | |
| V _F | Feedback output voltage | V _{SS} | V _{CC} | |
| V _{DSH} | High side desat/feedback input voltage | V _{S1,2,3} - 0.3 | V _{B1,2,3} | |
| V _{DSL} | Low side desat/feedback input voltage | - 0.3 | V _{CC} | |
| V _{BR} | BRAKE output voltage | V _{COM} | V _{CC} | |
| T _A | Ambient temperature | -20 | 115 | °C |

Note 1: Logic operational for V_S of COM-5V to COM+1200V. Logic state held for V_S of COM-5V to COM-V_{BS}.

Static Electrical Characteristics

V_{BIAS} (V_{CC} , $V_{BS1,2,3}$) = 15V and T_A = 25°C unless otherwise specified. The V_{IN} , V_{TH} and I_{IN} parameters are referenced to V_{SS} and are applicable to all six channels (HOP/HOQ/HON1,2,3 and LOP/LOQ/LON1,2,3). The V_O and I_O parameters are referenced to COM and $V_{S1,2,3}$ and are applicable to the respective output leads: HO1,2,3 and LO1,2,3. V_{DESAT} and I_{DESAT} parameters are referenced to COM and $V_{S1,2,3}$

| Symbol | Definition | Min. | Typ. | Max. | Units | Test Conditions |
|--------------|---|------|------|------|---------|--|
| V_{CCUV+} | V_{CC1} supply undervoltage positive going threshold | 10.3 | 11.2 | 12.5 | V | |
| V_{CCUV-} | V_{CC1} supply undervoltage negative going threshold | 9.5 | 10.2 | 11.3 | | |
| V_{CCUVH} | V_{CC1} supply undervoltage lockout hysteresis | — | 1.0 | — | | |
| V_{BSUV+} | V_{BS} supply undervoltage positive going threshold | 10.3 | 11.2 | 12.5 | | |
| V_{BSUV-} | V_{BS} supply undervoltage negative going threshold | 9.5 | 10.2 | 11.3 | | |
| V_{BSUVH} | V_{BS} supply undervoltage lockout hysteresis | — | 1.0 | — | | |
| I_{LK} | Offset supply leakage current | — | — | 50 | μA | $V_{B1,2,3} = V_{S1,2,3} = 1200V$ |
| I_{QBS} | Quiescent V_{BS} supply current | — | 150 | 250 | mA | $V_{LIN}=0V, V_{HIN}=5V$ |
| I_{QCC} | Quiescent V_{CC} supply current | — | 3 | 6 | | $V_{LIN}=0V, V_{HIN}=5V$ $DT = 1\mu sec$ |
| V_{IH} | Logic "0" input voltage (HIN/N, BRIN/N) (OUT=LO) | 2.0 | — | — | V | $V_{CC} = 12.5$ to $20V$ |
| V_{IL} | Logic "1" input voltage (HIN/N, BRIN/N) (OUT=HI) | — | — | 0.8 | | |
| V_{t+} | Logic input positive going threshold (HIN/N, LIN, BRIN/N, SD) | 1.2 | 1.6 | 2.0 | | |
| V_{t-} | Logic input negative going threshold (HIN/N, LIN, BRIN/N, SD) | 0.8 | 1.2 | 1.6 | | |
| ΔV_T | Logic input hysteresis (HIN, LIN, BRIN, SD) | — | 0.4 | — | | |
| V_{OH} | High level output voltage, $V_{BIAS} - V_O$ (normal switching) HOP, HOQ, LOP, LOQ | — | — | 100 | mV | $I_o = 1mA$ |
| V_{OL} | Low level output voltage, V_O (normal switching) HON, LON | — | — | 100 | | |
| I_{IN+} | Logic "1" input bias current (HIN/N, BRIN/N) | — | 5 | — | μA | $V_{IN} = 0V$ |
| | Logic "1" input bias current (LIN, SD) | — | 70 | — | | $V_{IN} = 5V$ |
| I_{IN-} | Logic "0" input bias current (HIN/N, BRIN/N) | — | 70 | — | | $V_{IN} = 5V$ |
| | Logic "0" input bias current (LIN, SD) | — | 5 | — | | $V_{IN} = 0V$ |
| I_{DS+} | High DSH, DSL, DSB input bias current | — | 15 | — | | $V_{DESAT} = 15V$ |
| I_{DS-} | Low DSH, DSL, DSB input bias current | — | 0.1 | — | | $V_{DESAT} = 0V$ |
| I_{O1+} | Output high first stage short circuit pulsed current | 220 | 350 | — | mA | $V_O = 0V, V_{IN} = 0V$ $PW \leq 200 ns$ |
| I_{O2+} | Output high second stage short circuit pulsed current | 120 | 200 | — | | $V_O = 0V, V_{IN} = 0V$ $PW \leq 10 \mu s$ |
| I_{O-} | Output low short circuit pulsed current | 460 | 540 | — | | $V_O = 15V, V_{IN} = 5V$ $PW \leq 10 \mu s$ |

Static Electrical Characteristics cont.

V_{BIAS} (V_{CC} , $V_{BS1,2,3}$) = 15V and T_A = 25°C unless otherwise specified. The V_{IN} , V_{TH} and I_{IN} parameters are referenced to V_{SS} and are applicable to all six channels (HOP/HOQ/HON1,2,3 and LOP/LOQ/LON1,2,3). The V_O and I_O parameters are referenced to COM and $V_{S1,2,3}$ and are applicable to the respective output leads: HO1,2,3 and LO1,2,3. V_{DESAT} and I_{DESAT} parameters are referenced to COM and $V_{S1,2,3}$

| Symbol | Definition | Min. | Typ. | Max. | Units | Test Conditions |
|--------------|--|------|------|------|----------|--|
| I_{OBR+} | BR output high short circuit pulsed current | 40 | 70 | — | mA | $V_{BR}=0V$, $V_{BRIN}=0V$ $PW \leq 10 \mu s$ |
| I_{OBR-} | BR output low short circuit pulsed current | 80 | 125 | — | | $V_{BR}=15V$, $V_{BRIN}=5V$ $PW \leq 10 \mu s$ |
| V_{OHB} | BR high level output voltage, $V_{CC}-V_{BR}$ | — | — | 300 | mV | $I_{BR} = 1mA$ |
| V_{OLB} | BR low level output voltage, V_{BR} | — | — | 150 | | |
| V_{OLVF} | VFH or VFL low level output voltage | — | — | 0.8 | V | $I_{VF} = 10mA$ |
| $R_{ON,VF}$ | VFH or VFL output on resistance | — | 60 | — | Ω | |
| $R_{ON,SS}$ | Soft shutdown on resistance | — | 500 | — | | |
| $R_{ON,FLT}$ | FAULT low on resistance | — | 60 | — | | |
| V_{DESAT+} | High DSH1,2,3 and DSL1,2,3 and DSB input threshold voltage | — | 8.0 | — | V | |
| V_{DESAT-} | Low DSH1,2,3 and DSL1,2,3 or DSB input threshold voltage | — | 7.0 | — | | |
| V_{DSTH} | DS input voltage hysteresis | — | 1.0 | — | | |

AC Electrical Characteristics

V_{BIAS} (V_{CC} , V_{BS}) = 15V, $V_{S1,2,3} = V_{SS}$, $T_A = 25^\circ C$ and $C_L = 1000$ pF unless otherwise specified.

| Symbol | Definition | Min. | Typ. | Max. | Units | Test Conditions |
|--|--|------|------|------|---|---|
| Propagation Delay Characteristics | | | | | | |
| T_{on1} | Turn-on first stage duration time | — | 200 | — | ns | $V_{IN} = 0$ & 5V $R_L(HOQ/LOQ) = 10\Omega$ |
| t_{on} | Turn-on propagation delay | 250 | 550 | 750 | | $V_{IN} = 0$ & 5V $V_{S1,2,3} = 0$ to 1200V HOP=HON,LOP=LON Figure 5 |
| t_{off} | Turn-off propagation delay | 250 | 550 | 750 | | |
| t_r | Turn-on rise time | — | 80 | — | | |
| t_f | Turn-off fall time | — | 25 | — | | |
| t_{DESAT1} | DSH to HO soft shutdown propagation delay at HO turn-on | — | 3000 | — | | $V_{HIN} = 0V$, $V_{DESAT} = 15V$, Figure 7 |
| t_{DESAT2} | DSH to HO soft shutdown propagation delay after blanking | 1000 | — | — | | |
| t_{DESAT3} | DSL to LO soft shutdown propagation delay at LO turn-on | — | 3000 | — | $V_{LIN} = 5V$, $V_{DESAT} = 15V$, Fig.7 | |

AC Electrical Characteristics cont.

V_{BIAS} (V_{CC}, V_{BS}) = 15V, V_{S1,2,3} = V_{SS}, T_A = 25°C and C_L = 1000 pF unless otherwise specified.

| Symbol | Definition | Min. | Typ. | Max. | Units | Test Conditions |
|--|--|------|------|------|---|--|
| Propagation Delay Characteristics | | | | | | |
| t _{DESAT4} | DSL to LO soft shutdown propagation delay after blanking | 1000 | — | — | ns | V _{LIN} = 5V, V _{DESAT} = 15V, Fig. 7 |
| t _{DESAT5} | DSB to HO hard shutdown propagation delay | — | 1300 | — | | V _{HIN} = 0V, V _{DESAT} = 15V, Fig. 7 |
| t _{DESAT6} | DSB to LO hard shutdown propagation delay | — | 1300 | — | | V _{LIN} = 5V, V _{DESAT} = 15V, Fig. 7 |
| t _{DESAT7} | DSB to BR hard shutdown propagation delay | 1000 | — | — | | V _{VBRIN} = 0V, V _{DSB} = 15V, Fig. 7 |
| t _{VFHL1,2,3} | VFH high to low propagation delay | — | 550 | — | | V _{DESAT} = 15V to 0V Figure 8 |
| t _{VFHHL1,2,3} | VFH low to high propagation delay | — | 550 | — | | V _{DESAT} = 0V to 15V Figure 8 |
| t _{VFLH1,2,3} | VFL low to high propagation delay | — | 550 | — | | V _{DESAT} = 0V to 15V Figure 8 |
| t _{VFL1,2,3} | VFL high to low propagation delay | — | 550 | — | | V _{DESAT} = 15V to 0V Figure 8 |
| t _{PWVF} | Minimum pulse width of VFH and VFL | — | 400 | — | | V _{DESAT} = 15V to 0V or 0V to 15V fig. 8 |
| t _{DS} | Soft shutdown minimum pulse width of DSx | 1000 | — | — | | C _L = 1000pF, V _{DS} = 15V Figure 6 |
| t _{SS} | Soft shutdown duration period | — | 6000 | — | | |
| t _{FLT,DESAT1} | DSH to FAULT propagation delay at HO turn-on | — | 3300 | — | | V _{HIN} = 0V, V _{DS} = 15V, Fig. 7 |
| t _{FLT,DESAT2} | DSH to FAULT propagation delay after blanking | — | 1300 | — | | |
| t _{FLT,DESAT3} | DSL to FAULT propagation delay at LO turn-on | — | 3300 | — | | V _{LIN} = 5V, V _{DS} = 15V, Fig. 7 |
| t _{FLT,DESAT4} | DSL to FAULT propagation delay after blanking | — | 1000 | — | | |
| t _{FLTDSB} | DSB to FAULT propagation delay | — | 1000 | — | BRIN = 0V, V _{DESAT} = 15V, Fig. 7 | |
| t _{FLTCLR} | LIN1 = LIN2 = LIN3 = 0 to FAULT | 9.0 | — | — | V _{DESAT} = 15V, Fig. 7 | |
| t _{fault} | Minimum FAULT duration period | 9.0 | 15.0 | 21.0 | μs V _{DESAT} = 15V, Fig. 11 FLTCLR pending | |
| t _{BL} | DS blanking time at turn-on | — | 3000 | — | V _{IN} = on, V _{DESAT} = 15V, Fig. 7 | |
| t _{SD} | SD to output shutdown propagation delay | — | 600 | 900 | V _{IN} = on, V _{DESAT} = 0V, Fig. 10 | |

AC Electrical Characteristics cont.

$V_{BIAS} (V_{CC}, V_{BS}) = 15V$, $V_{S1,2,3} = V_{SS}$, $T_A = 25^\circ C$ and $C_L = 1000 \text{ pF}$ unless otherwise specified.

| Symbol | Definition | Min. | Typ. | Max. | Units | Test Conditions |
|--|---|------|------|------|-------|---|
| Propagation Delay Characteristics | | | | | | |
| t_{EN} | SD negation to output enable propagation delay | — | 600 | 900 | | $V_{IN} = 0V$ $V_{DESAT} = 0V$, Fig.10 |
| t_{onBR} | BR output turn-on propagation | — | 110 | 200 | ns | Figure 5 |
| t_{offBR} | BR output turn-off propagation | — | 80 | 150 | | |
| t_{rBR} | BR output turn-on rise time | — | 235 | 400 | | |
| t_{fBR} | BR output turn-off fall time | — | 130 | 200 | | |
| Deadtime/Delay Matching Characteristics | | | | | | |
| DT | Deadtime | 900 | 1050 | 1200 | ns | Figure 8 external resistor=39k Ω |
| | | 76 | 100 | 124 | | Figure 8 external resistor=0k Ω |
| | | 4500 | 5000 | 5500 | | Figure 8 external resistor=220k Ω |
| MDT | Deadtime asymmetry skew, any of DTLoff1,2,3-DTHoff1,2,3 | — | — | 145 | | DT=1000nsec. Fig.8 |
| PM | PWM propagation delay matching max {ton/toff} - min {ton/toff}, (ton/toff are applicable to all six channels) | — | — | 125 | | DT=1000nsec. Fig.5 |
| VM | Voltage feedback delay matching, any of $t_{VFHL1,2,3}$, $t_{VFHH1,2,3}$, $t_{VFLL1,2,3}$, $t_{VFLH1,2,3}$ - any of $t_{VFHL1,2,3}$, $t_{VFHH1,2,3}$, $t_{VFLL1,2,3}$, $t_{VFLH1,2,3}$ | — | — | 125 | | Input pulse width >400 nsec Figure 9 |

Functional Block Diagram

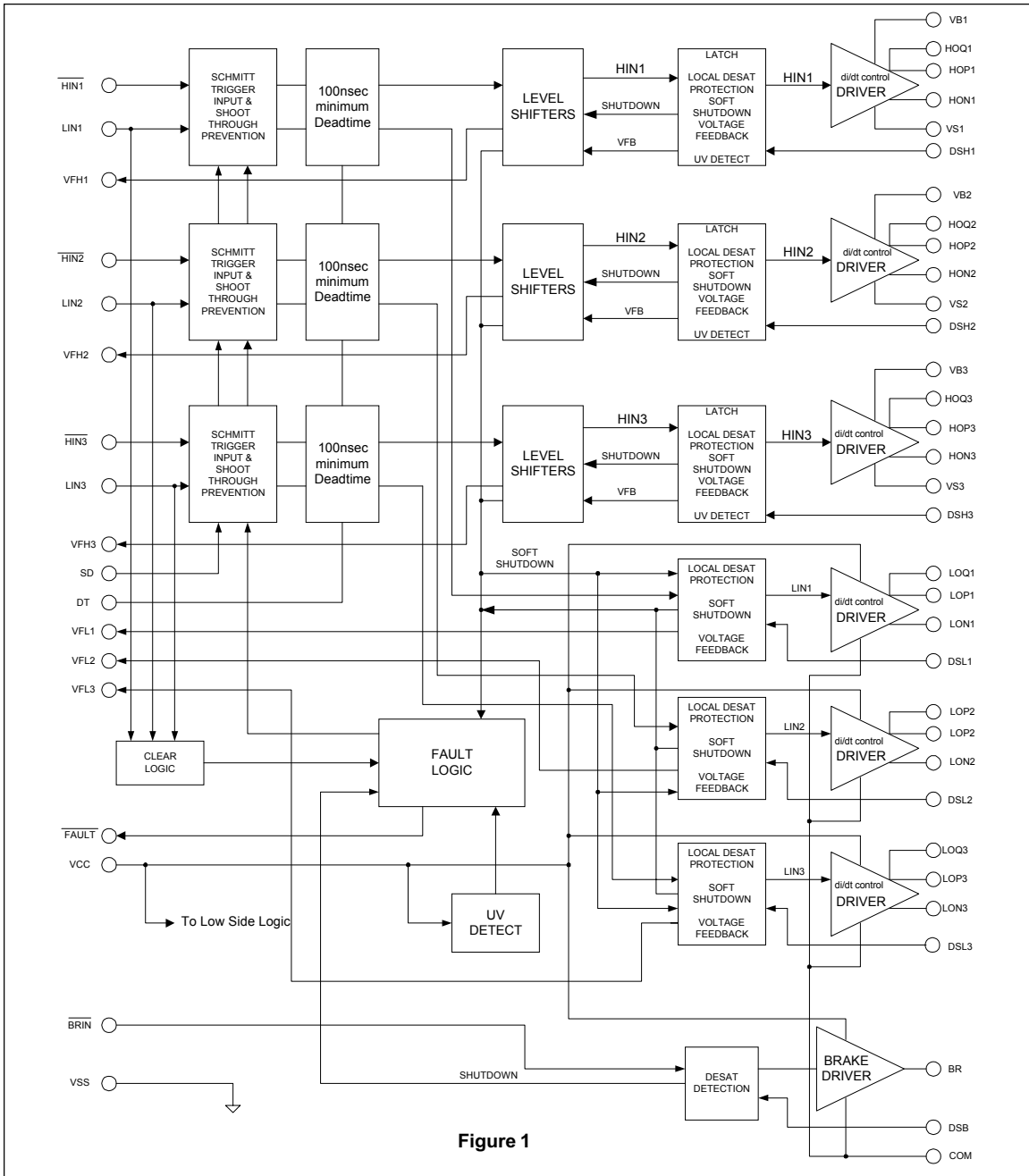

Figure 1

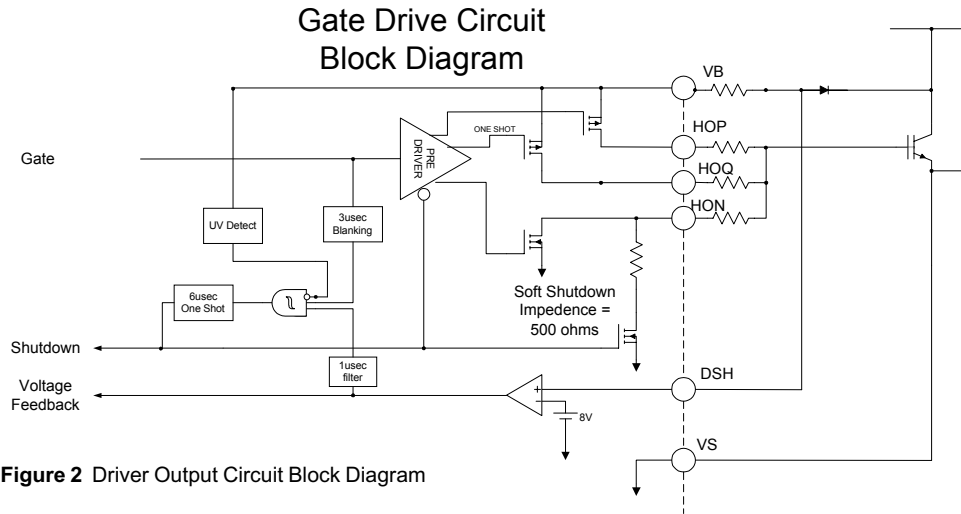

Figure 2 Driver Output Circuit Block Diagram

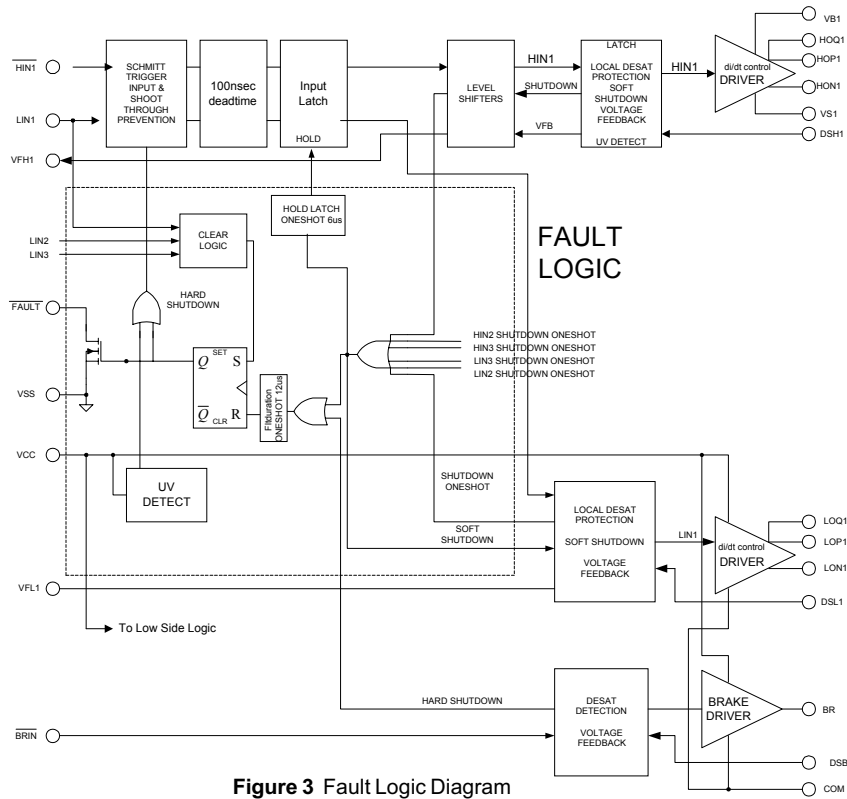

Figure 3 Fault Logic Diagram

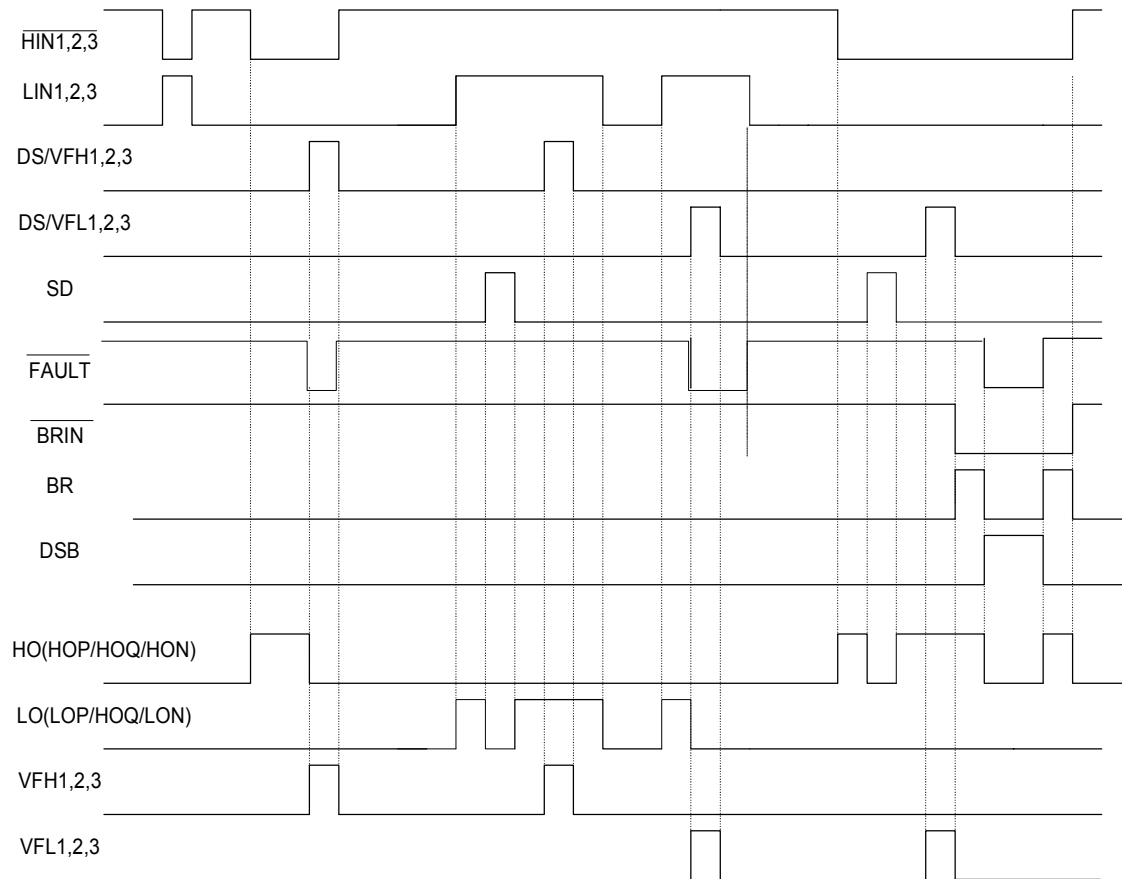

Figure 4 Input/Output Timing Diagram

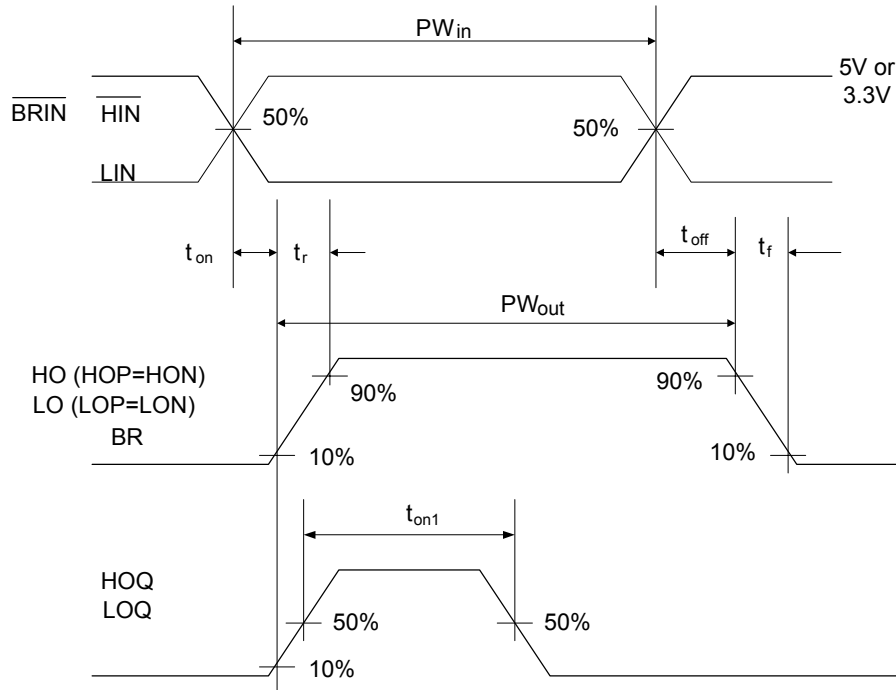

Figure 5 Switching Time Waveforms

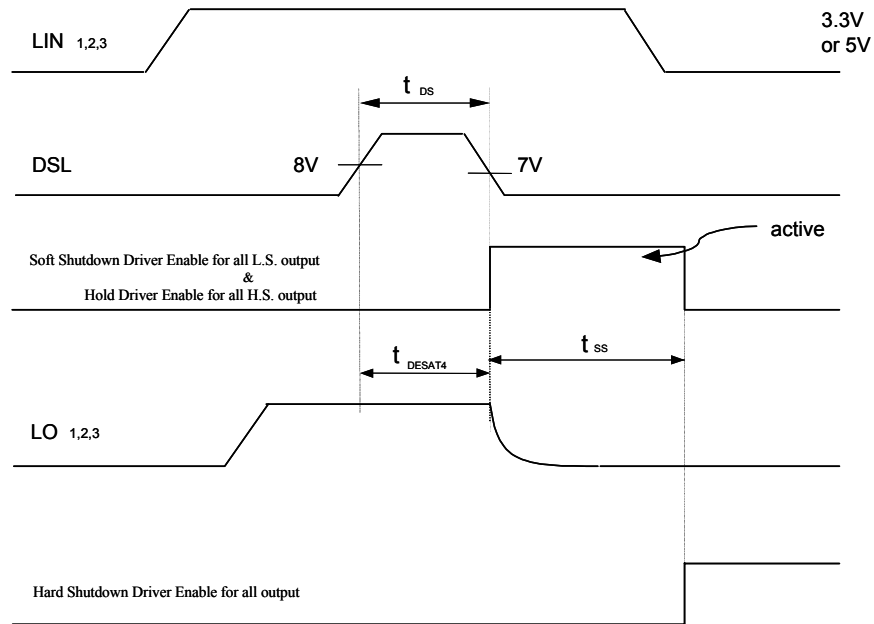

Figure 6.1 Low Side Desat Soft Shutdown Timing Waveform

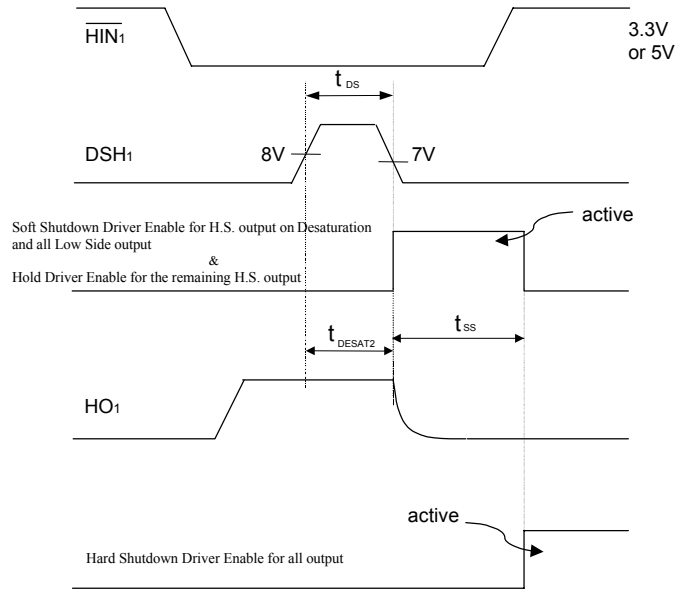

Figure 6.2 High Side Desat Soft Shutdown Timing Waveform

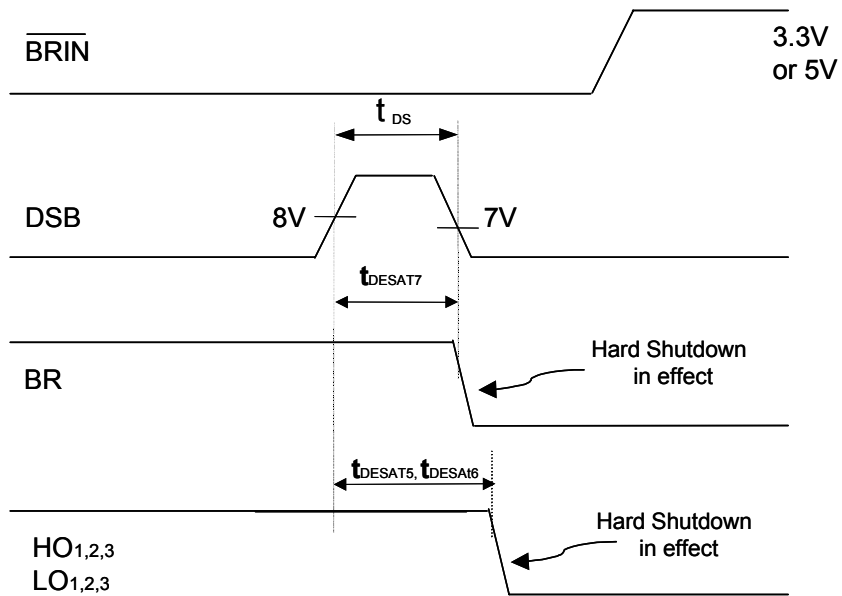

Figure 6.3 Brake Desat Timing Waveform

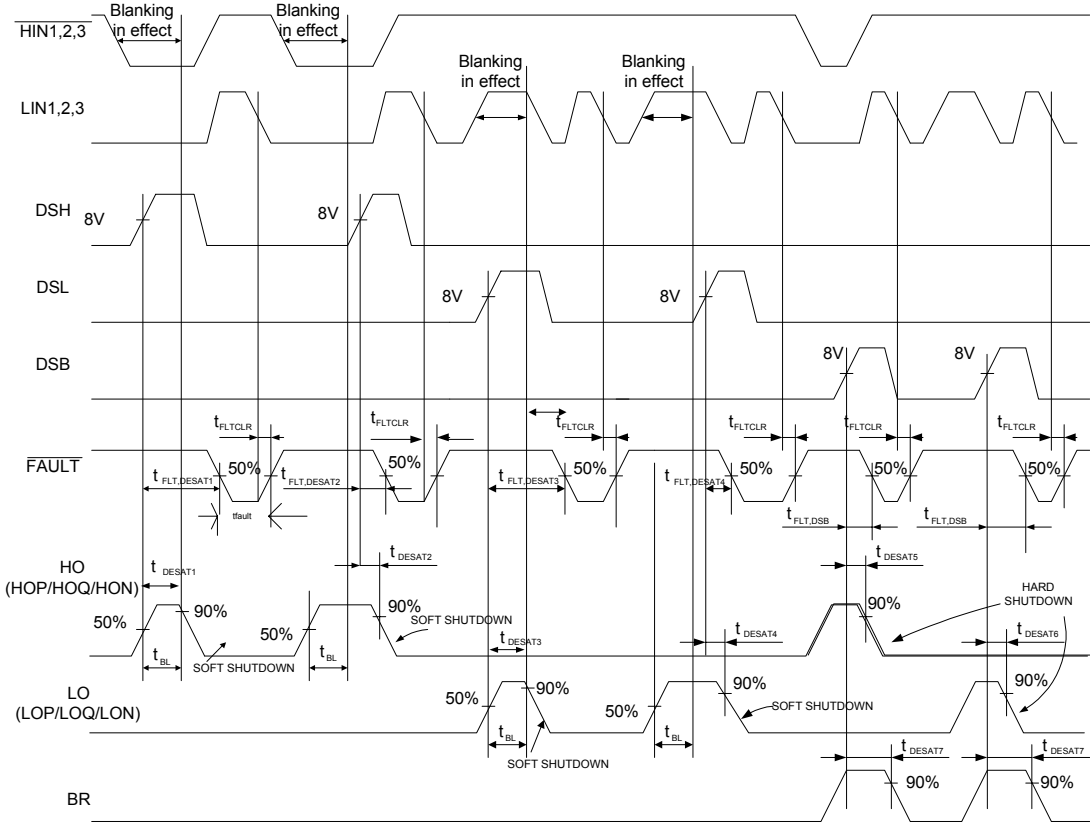

Figure 7 Desat Timing Diagram

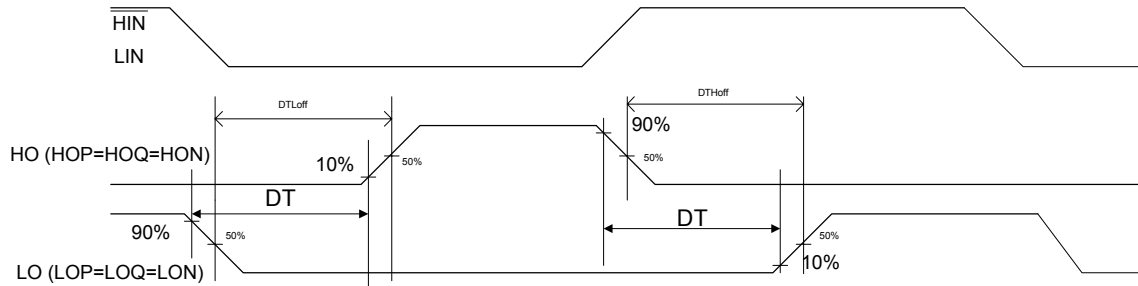

Figure 8 Internal Deadtime Timing

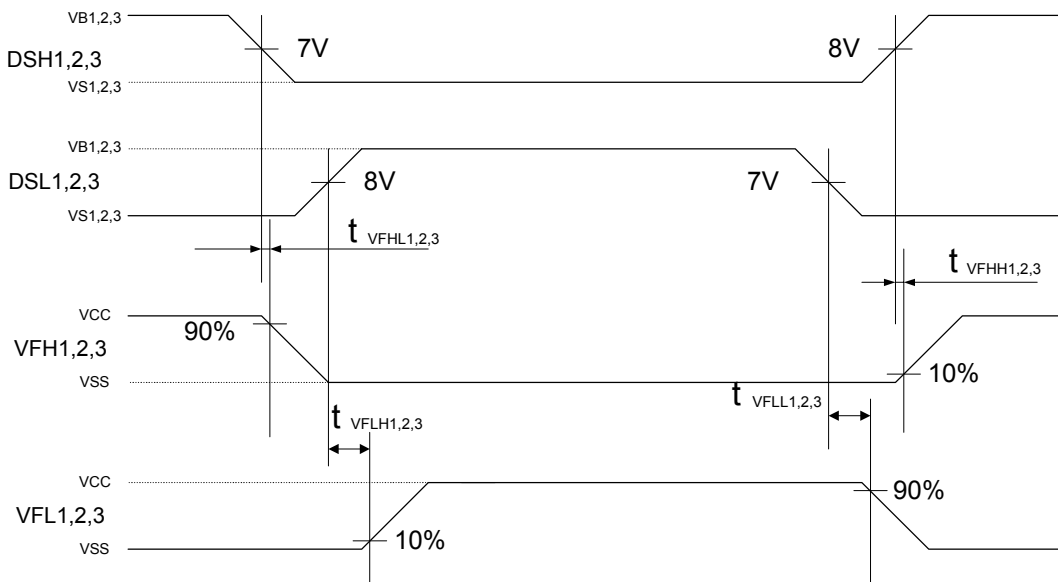

Figure 9 Voltage Feedback Timing

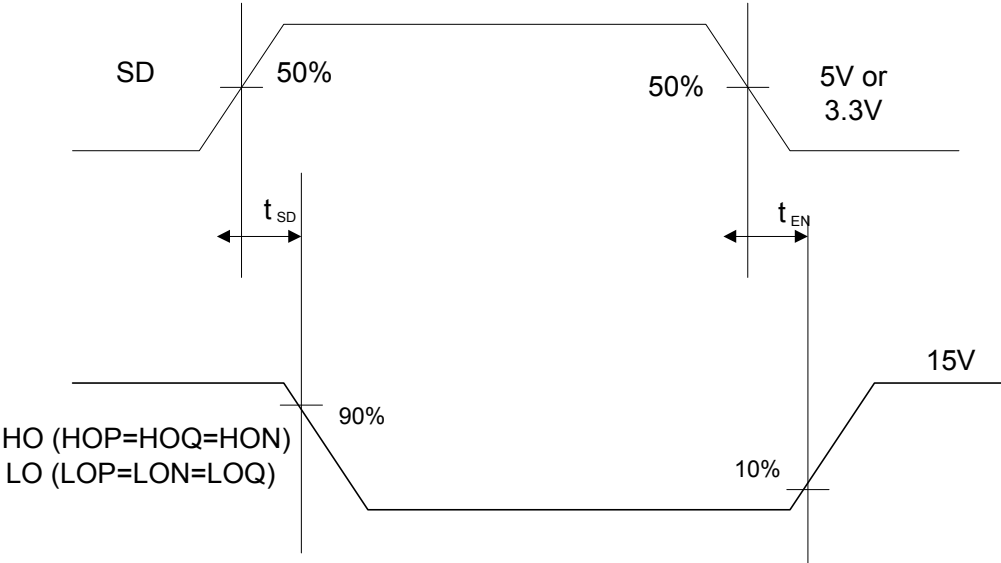

Figure 10 Shutdown Timing

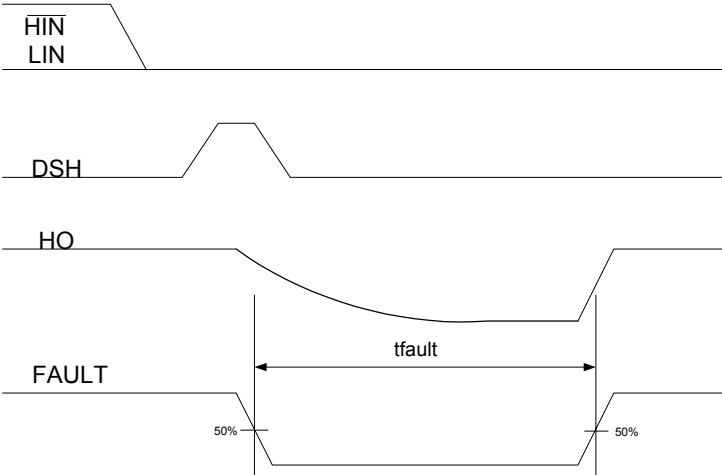

Figure 11 Fault Duration with Pending Faultclear Waveform
(refer to Note LD2 under the lead definition table)

Lead Definitions

| Symbol | Description |
|---------------------------------|--|
| V _{CC} | Low side supply voltage |
| V _{SS} | Logic Ground |
| HIN _{1,2,3} | Logic inputs for high side gate driver outputs (HOP _{1,2,3} /HON _{1,2,3} , out of phase) |
| LIN _{1,2,3} | Logic inputs for low side gate driver outputs (LOP _{1,2,3} /LON _{1,2,3} , out of phase) |
| FAULT | Fault output (latched and open drain) |
| SD | Shutdown input |
| DT | Deadtime programmable resistor pin |
| DSB | Brake IGBT desaturation protection input and voltage feedback input |
| BRIN | Logic input for brake driver |
| BR | Brake driver output |
| COM | Low side drivers return |
| V _B _{1,2,3} | High side gate drive floating supply |
| HOP _{1,2,3} | High side driver sourcing output |
| HOQ _{1,2,3} | High side driver boost sourcing output |
| HON _{1,2,3} | High side driver sinking output |
| DSH _{1,2,3} | IGBT desaturation protection input and high side voltage feedback input |
| V _S _{1,2,3} | High voltage floating supply return |
| LOP _{1,2,3} | Low side driver sourcing output |
| LON _{1,2,3} | Low side driver sinking output |
| DSL _{1,2,3} | IGBT desaturation protection input and low side voltage feedback input |
| VFH _{1,2,3} | High side voltage feedback logic output |
| VFL _{1,2,3} | Low side voltage feedback logic output |

NOTE:

LD1- Low side soft shutdown is initiated locally in an event over current, which is sensed by the DSL pin. It is followed by the synchronized soft shutdown of the rest of the low side outputs; meanwhile it will hold all input information for a period of t_{ss} until the soft shutdown finishes. Then the hard shutdown will be initiated to complete the shut down cycle. (Figure 6.1)

High side soft shutdown is initiated locally in an event over current, which is sensed by the DSH pin. It is followed by the synchronized soft shutdown of all the low side outputs; meanwhile it will hold all input information for a period of t_{ss} until the soft shutdown finishes. Then the hard shutdown will be initiated to complete the shut down cycle. (Figure 6.2)

LD2- Soft shutdown is initiated in an event of overcurrent, which is followed by turn-off all six outputs. The fault condition will remain in a fixed period(t_{fault}) even though the faultclear condition is in effect (Fig11). In the case that faultclear is not in effect, fault duration = $t_{fault} + t_{ftclr}$.

Lead Assignments

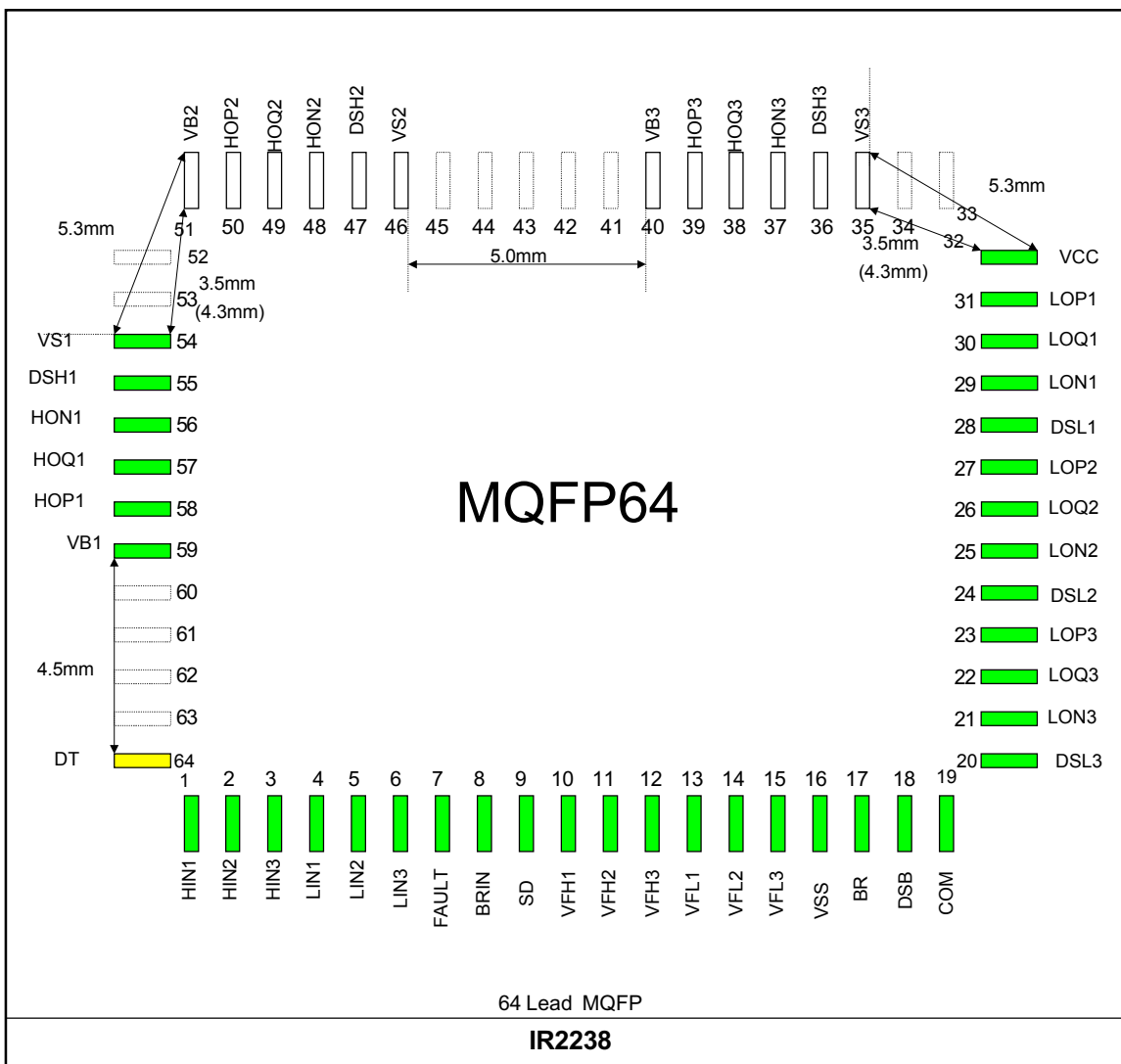

Case outline

