

Power Profiler Kit

User Guide

v2.2

Contents

Revision history	iv
1 Introduction	5
2 Minimum requirements	6
3 Kit content	7
3.1 Hardware content	7
3.2 Downloadable content	7
3.3 Related documentation	7
4 Quick start	9
5 Power Profiler Kit overview	11
5.1 Measurement system	11
5.1.1 Block diagram	11
5.1.2 Power supply	11
5.1.3 Measurement ranges and switch levels	12
5.1.4 DUT output	12
5.1.5 EEPROM	13
5.1.6 Display interface and joystick	13
5.2 Connectors	13
5.3 Switches	14
6 Configuring Power Profiler Kit	17
6.1 Optimizing measurement accuracy	17
6.1.1 Power Profiler Kit use with nRF5 DK	17
6.1.2 Current measurement on external DUTs	17
6.2 Connecting Power Profiler Kit to nRF5 DK	18
6.3 Measuring current on nRF5 DK	18
6.4 Measuring current on nRF5 DK while debugging	19
6.5 Measuring current on custom hardware with nRF5 DK	20
6.6 Measuring current on custom hardware without nRF5 DK	21
7 Connecting Power Profiler Kit to a computer	23
8 Installing Power Profiler Kit software package	24
9 Using Power Profiler Kit application	25
10 Electrical specifications	26
10.1 Environmental specifications	26
10.2 Power supply specifications	26
10.3 Measurement specifications	26
10.3.1 Maximum DUT admissible current	26
10.3.2 Measurement resolution	27
10.3.3 Measurement accuracy	27

11 Troubleshooting	28
Legal notices	29

Revision history

Date	Version	Description
June 2018	2.2	Updated the content to clarify that when using a standalone SEGGER J-Link debugger, v1.1 of the Python-based PPK software must be used
March 2018	2.1	The following content was corrected: <ul style="list-style-type: none">• Quick start on page 9• Troubleshooting on page 28
March 2018	2.0	Updated due to new software
July 2017	1.1	Updated to match PPK v1.1.0 Settings window updated: <ul style="list-style-type: none">• A new tab added, see Using Power Profiler Kit application on page 25• Logging feature added, see File menu options Updated: <ul style="list-style-type: none">• Installing Power Profiler Kit software package on page 24• Troubleshooting on page 28
October 2016	1.0	First release

1 Introduction

The Power Profiler Kit (PPK) is an affordable, flexible tool that measures the real-time power consumption of your designs.

[Power Profiler Kit Product Brief v2.0](#)

The PPK measures power consumption for a connected nRF5 Development Kit or any external board. It measures current from 1 μA up to 70 mA and gives a detailed picture of the current profile for the user application.

The PPK can be used in conjunction with the nRF5 DK to measure current on the nRF5 DK or on an external board. The hardware is delivered with an application that is installed using [nRF Connect for desktop](#). There are several measurement configurations, which are described in this user guide.

Key features

- Variable power supply voltage ranging from 1.8 V to 3.6 V (software configurable)
- Maximum 70 mA current measurement
- Resolution down to 0.2 μA
- Automatic switching between three current measurement ranges ensuring optimal resolution
- Measurement accuracy better than +/-20 % (average currents measurement)
- Desktop application for measurement analysis
- Real-time current measurement display
- Recording display up to two minutes
- Real-time display with a resolution down to 13 μs
- Internal/external trigger

Applications

- Quick power consumption measurements on a firmware running on an nRF5 DK
- Quick power consumption measurements on a firmware running on an external board
- Accumulative measurements, such as average, peak, maximum
- Instantaneous measurements presented as waveform plots



Environmental Protection

Waste electrical products should not be disposed of with household waste.

Please recycle where facilities exist. Check with your local authority or retailer for recycling advice.

2 Minimum requirements

Before you start setting up the Power Profiler Kit (PPK), check that you have the required hardware and software.

Hardware requirements

- USB cable for connecting the PPK to a USB port of a computer
- nRF5 Development Kit (DK) or a standalone SEGGER J-Link debugger (only supported by v1.1 of the Python-based PPK software)

Software requirements

The supported operating systems are:

- Microsoft Windows 7/8/10
- Mac OS
- Linux

To install the PPK software package, the nRF Connect desktop application is needed. It can be downloaded from the [nRF Connect for Desktop](#) product page. For more information, see the [nRF Connect](#) documentation.

3 Kit content

The Power Profiler Kit consists of hardware and access to software components, reference design files, and documentation.

3.1 Hardware content

The Power Profiler Kit (PPK) hardware content consists of the PPK board PCA63511.

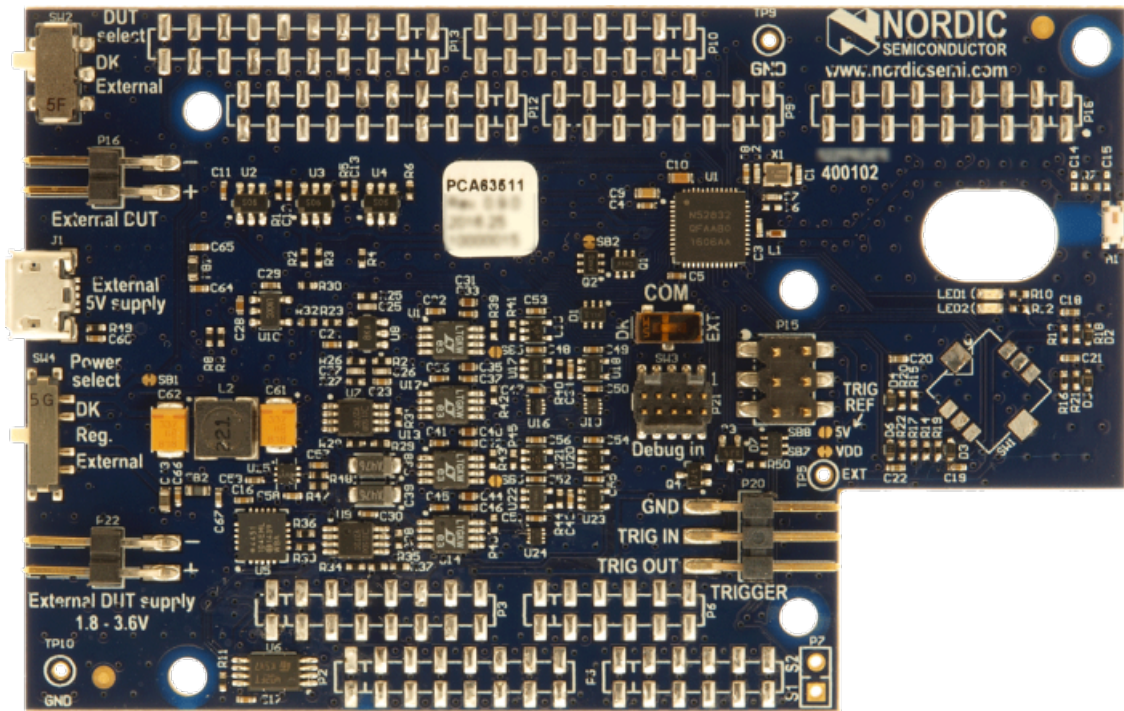

Figure 1: Power Profiler Kit (PPK) board (PCA63511)

3.2 Downloadable content

The downloadable content for PPK consists of hardware files and this user guide.

You can download the hardware files from the [Power Profiler Kit](#) product page.

The hardware zip file contains the following files for the PCA63511 board:

- Altium Designer files
- Production files (bill of materials and assembly, drill, Gerber, and pick-and-place files)
- PCB layout files and schematics in PDF format

You also need [nRF Connect for desktop](#).

3.3 Related documentation

In addition to the information in this document, you may need to consult other documents.

Nordic documentation

- [nRF51 Development Kit](#)
- [nRF52 Development Kit](#)
- [nRF52840 Development Kit](#)

4 Quick start

Complete a few steps to set up your Power Profiler Kit (PPK). In the simplest configuration, the PPK is connected to an nRF5 Development Kit (DK, not included in the package).

In this quick start, the PPK measures current on the nRF5 DK device, which also acts as a power supply and sends data to the Power Profiler application.

See Nordic Semiconductor Infocenter for information on the [nRF51 Series](#) and [nRF52 Series](#).

Complete the following steps:

1. Prepare the nRF5 DK for current measurements by cutting the nRF current measurement solder bridge. For more details, see:
 - Section *Preparing the development kit board* in [nRF51 Development Kit User Guide](#)
 - [Preparing the development kit board](#) in [nRF52 DK User Guide](#)
 - [Preparing the development kit board](#) in [nRF52840 PDK User Guide](#)
2. Connect the PPK to the nRF5 DK as shown in the following figure.

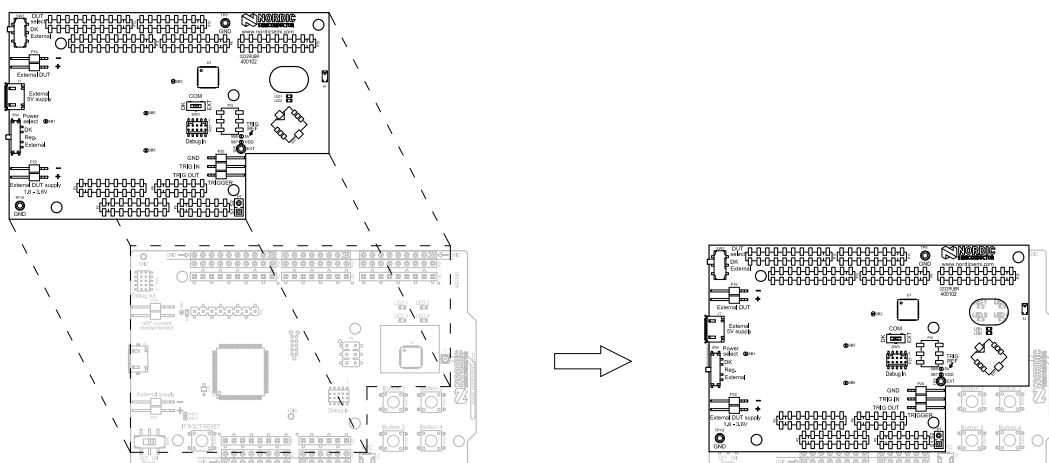

Figure 2: Connecting the PPK to the nRF5 DK

3. Connect the USB cable to the nRF5 DK and a computer.

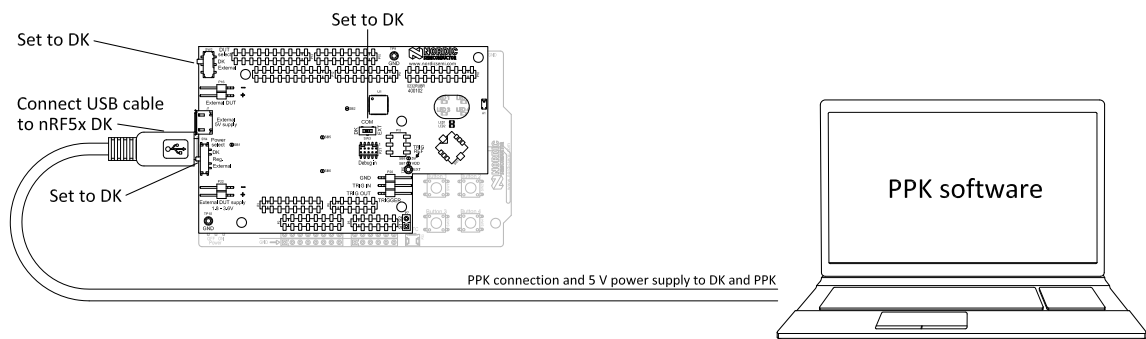

Figure 3: Typical configuration for measuring current on the nRF5 DK

4. Set the switches on the PPK as shown in the figure above.
5. Install the PPK software as described in [Installing Power Profiler Kit software package](#) on page 24.
6. Start the Power Profiler application as described in [Using Power Profiler Kit application](#) on page 25.

The PPK is ready to use.

5 Power Profiler Kit overview

The Power Profiler Kit (PPK) contains both hardware and software components.

5.1 Measurement system

The PPK is driven by the nRF52832 SoC, which uses its ADC (analog-to-digital converter) to measure a voltage drop over a series of measurement resistors. Resistor values are used to calculate the power consumption. The PPK has three different measurement ranges, which are managed by an automatic switch circuitry.

To send the data to the desktop application, the nRF52832 SoC on the PPK uses the SEGGER RTT (Real-Time Transfer). By connecting the PPK to an nRF5 DK, the SEGGER J-Link debug probe available on the nRF5 DK can be used for the computer connection. Alternatively, an external SEGGER J-Link debugger can be used.

5.1.1 Block diagram

The Power Profiler Kit (PPK) block diagram illustrates the overall system and connections between the various blocks.

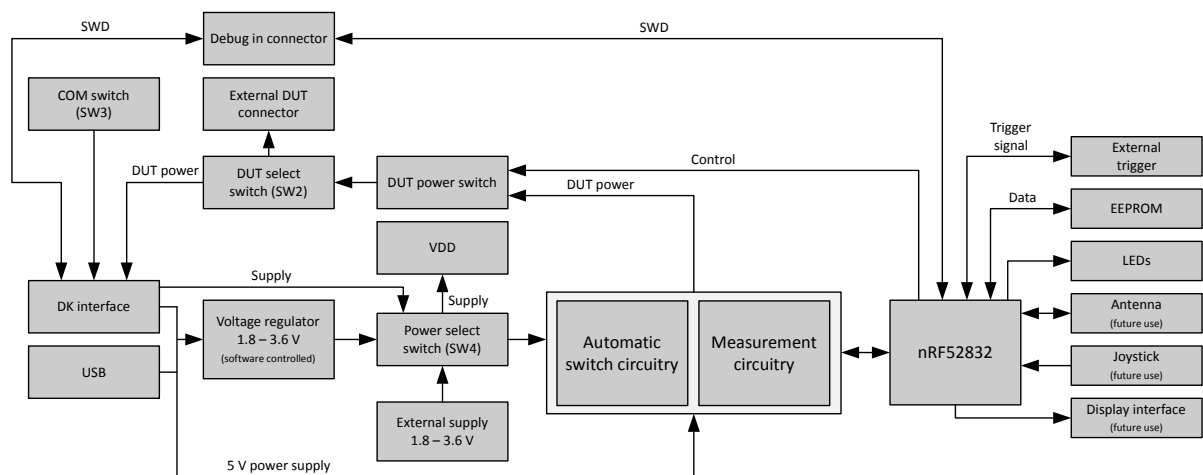

Figure 4: Block diagram

5.1.2 Power supply

There are three power supply options for the the Power Profiler Kit (PPK) digital logic and for the device under test (DUT).

The power supply options are:

- DK interface
- PPK onboard voltage regulator
- External supply

The power supply is selected using the power select switch (**SW4**).

The PPK onboard voltage regulator is supplied by the 5 V USB power supply. Its output can be adjusted between 1.8 V and 3.6 V through the Power Profiler application.

If an external power supply is used, the voltage is applied directly to the circuits without regulation. This voltage must be limited to the 1.8–3.6 V range.

When the DK is selected as the power supply, the DK supplies the PPK circuitry.

The analog part of the automatic switch circuitry requires a 5 V power supply. When the PPK is connected to an nRF5 DK, the 5 V is supplied by the DK. When the PPK is used standalone, a USB cable has to be connected to supply the 5 V required by the circuitry.

5.1.3 Measurement ranges and switch levels

To achieve a high measurement dynamic range, the PPK features three calibrated parallel measurement means realizing the three measurement ranges simultaneously. An automatic range switching mechanism always selects the correct measurement range depending on the instantaneous current draws by the DUT.

If your DUT has a power consumption that is close to a switching point, it can cause rapid switching between the ranges, creating measurement errors and distorted plots. A hysteresis is applied at the switching point in order to avoid distorted measurements as shown in the following figure.

There are four switch levels:

Switch up LOW

Switches up from low to medium range

Switch up HIGH

Switches up from medium to high range

Switch down HIGH

Switches down from high to medium range

Switch down LOW

Switches down from medium to low range

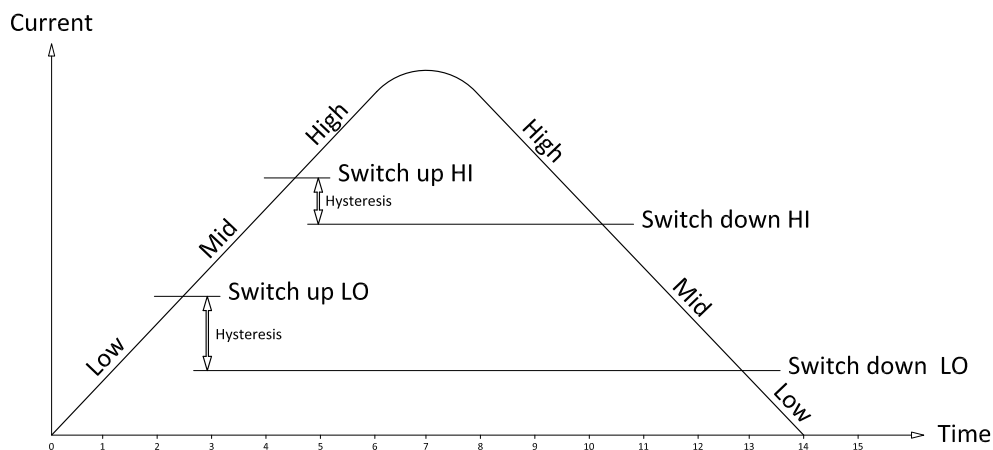

Figure 5: Measurement ranges and switch levels

5.1.4 DUT output

For device under test (DUT) output, the PPK supports two modes of operation that can be selected using the DUT select switch (**SW2**).

The two modes of operation are the following:

- Measuring current on the nRF5 DK device
- Supplying power and measuring current on an external board

The DUT can be turned on and off using the power switch (**Power OFF**) in the Power Profiler application. See [Figure 15: Settings and Plots view in the Power Profiler application](#) on page 25.

5.1.5 EEPROM

On the PPK, there is an EEPROM memory connected to the nRF52832 SoC. The EEPROM is used to store calibration data.

5.1.6 Display interface and joystick

Reserved for future use.

5.2 Connectors

Access to the Power Profiler Kit (PPK) is available from a set of connectors.

The PPK has five connectors on the top side:

- Two connectors for the power supply:
 - **P16** to connect an external device under test (DUT)
 - **J1** for the USB
- **P22** for connecting the custom/external hardware
- **P20** for connecting an external trigger
- **P21** connector for connecting an external SEGGER J-Link

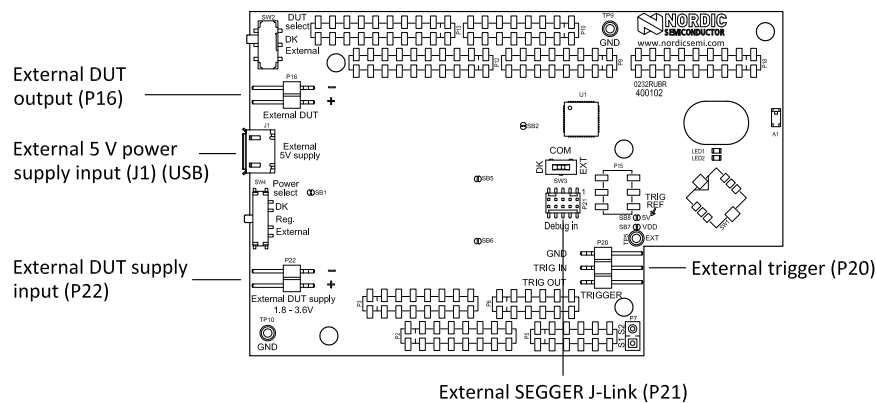

Figure 6: PPK connectors

The connectors on the bottom side are for connecting the PPK to an nRF5 DK, which supplies both data interface and power to the PPK.

Connector	Description
External 5 V power supply input (USB; J1)	<p>This USB connector on the PPK supplies the onboard analog measurement circuitry and the onboard regulator with 5 V provided by a USB host.</p> <p>This connector is used when the PPK is used standalone or any time the USB on the nRF5 DK is not connected.</p> <p>Note: When used with an nRF5 DK with USB connection, this connector must not be used.</p>
External DUT output (P16)	The External DUT connector provides power to the DUT.
External DUT supply input (P22)	A lab power supply from 1.8 to 3.6 V can be connected here to provide precise control of the voltage.
External trigger (P20)	<p>This connector allows you to:</p> <ul style="list-style-type: none"> • Feed an external trigger to the PPK (15 V max) • Have the PPK send a trigger signal to external instruments <p>The voltage of the TRIG OUT pin can be configured by the TRIG REF on the PPK board which has the following options:</p> <ul style="list-style-type: none"> • VDD: default • 5 V: cut SB7 and solder SB8 • External voltage: cut SB7 and SB8 (if shorted) and connect to TP5 (EXT)
External SEGGER J-Link (P21)	<p>Used to connect an external SEGGER J-Link for communicating with the desktop application when:</p> <ul style="list-style-type: none"> • The PPK is used standalone • The SEGGER J-Link on the nRF5 DK is used for debugging of the nRF5 chip on the DK <p>If this connector is in use and the PPK is connected to an nRF5 DK board, the COM switch (SW3) must be in the "EXT" position to disconnect the PPK from the SEGGER J-Link on the DK. How to connect and use is described in Table 2: PPK switches on page 15.</p> <p>Note: This feature is only supported by v1.1 of the Python-based PPK software when run on a standalone SEGGER J-Link.</p>

Table 1: PPK connectors

5.3 Switches

The Power Profiler Kit (PPK) has three switches: One for selecting the device under test (DUT) on which current is measured, one for the power supply, and one for the SEGGER J-Link connection.

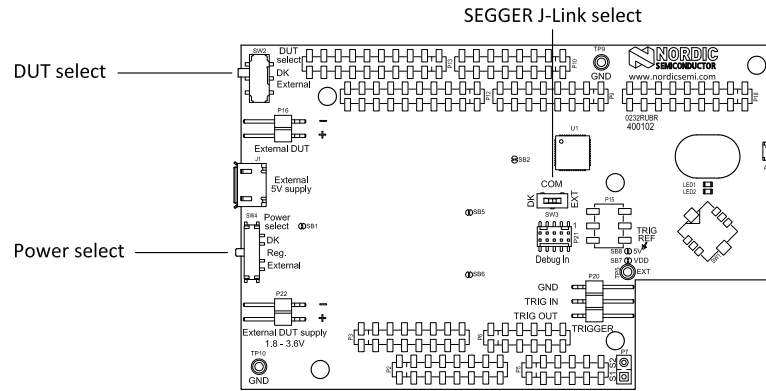

Figure 7: PPK switches

Switch	Description
DUT select (SW2)	<p>Selects if the measurements are performed on the nRF5 DK or on an external/custom hardware.</p> <p>Options:</p> <ul style="list-style-type: none"> • DK: The measurements are performed on the nRF5 DK. • External: The measurements are performed on the external/custom hardware connected to the External DUT (P16) connector.
Power select (SW4)	<p>Selects the power source for the PPK and DUT.</p> <p>Options:</p> <ul style="list-style-type: none"> • DK: The power source is the nRF5 DK. Used when measuring current on the nRF5 DK (that is, when the DUT select switch is in the "DK" position). • Reg.: The power source is the onboard regulator powering the PPK and the external DUT. Used when measuring current on the external/custom hardware (that is, when the DUT select (SW2) switch is in the "External" position). • External: An external power supply is the power source connected to the External DUT supply (P22) connector of the PPK. <p>Note:</p> <ul style="list-style-type: none"> • The Power Profiler application can be used to adjust the power supply voltage only when the Power select (SW4) switch is in the "Reg" position, that is, when the power is supplied by the PPK onboard regulator. • It is not recommended to use the PPK onboard regulator (SW4 in the "Reg" position) when measuring current on the nRF5 DK unless the PPK onboard regulator voltage exactly matches the nRF5 DK voltage. Otherwise, current leakage may occur and lead to erroneous current readings. <p>The voltage is usually somewhere between 2.9 V and 3 V. To be sure, it is recommended to measure the DK voltage. This configuration, although possible, is not recommended.</p>

Switch	Description
COM (SW3)	<p>This switch selects the SEGGER J-Link connection.</p> <p>Options:</p> <ul style="list-style-type: none"> • DK: The SEGGER J-Link on the nRF5 DK kit is used. • EXT: An external SEGGER J-Link is used and connected to the Debug in (P21) connector. This will disconnect the PPK from the SEGGER J-Link on the nRF5 DK. <p>Note:</p> <ul style="list-style-type: none"> • To program the DUT on the DK, the switch must be in the "EXT" position. When programming with the switch in the "DK" position, the PPK will be programmed. • When the PPK uses the nRF5 DK SEGGER J-Link, it cannot be used to debug the nRF5 SoC on the DK at the same time. To debug the nRF5 DK SoC on the DK, set the COM (SW3) switch to the "EXT" position.

Table 2: PPK switches

6 Configuring Power Profiler Kit

Four different configuration setups and methods for measuring current can be used for the Power Profiler Kit (PPK).

To configure the PPK, complete the following steps:

1. Adjust measurement accuracy as described in [Optimizing measurement accuracy](#) on page 17.
2. Choose a use case and implement a configuration for the PPK. The options are presented in the following table.

Use case	Configuration setup/measurement method
Design phase, no custom hardware	Measuring current on nRF5 DK on page 18.
Design and optimization phase, no custom hardware, with debugging	Measuring current on nRF5 DK while debugging on page 19.
Design phase, using external/custom hardware	Measuring current on custom hardware with nRF5 DK on page 20.
	Measuring current on custom hardware without nRF5 DK on page 21.

Table 3: PPK use cases

6.1 Optimizing measurement accuracy

When measuring current with the PPK, some adjustments are needed to optimize the measurement accuracy. The nRF5 DK must be prepared for the measurement.

6.1.1 Power Profiler Kit use with nRF5 DK

When the PPK is used with an nRF5 DK, it is recommended to use the Power select (**SW4**) switch in the "DK" position.

It is not recommended to use the PPK onboard regulator as the power source (the Power select switch (**SW4**) in the "Reg." position) as this may lead to erroneous current readings.

Note: If you want to improve the USB noise filtering, you need to use the PPK onboard regulator as the power source. Make sure that the PPK regulator voltage exactly matches the nRF5 DK voltage. Otherwise, current leakage may occur and lead to erroneous current readings.

6.1.2 Current measurement on external DUTs

When measuring current on external devices, it is important to keep in mind that large filtering capacitors, which may be present on the DUT circuit, will smooth out the variations in power consumption.

This yields a good result for the average power consumption, but the short current bursts will be filtered out and the plot might differ from what you see on the measurements done on the nRF5 DK during development.

You must include decoupling capacitors to ensure correct operation of the devices. However, as a good practice, keep extra decoupling capacitors to a minimum when measuring detailed current draw.

6.2 Connecting Power Profiler Kit to nRF5 DK

For all of the PPK configurations, except when the PPK is running standalone, the PPK needs to be connected to the nRF5 Development Kit (DK).

Connect your PPK to the nRF5 DK as shown in the following figure.

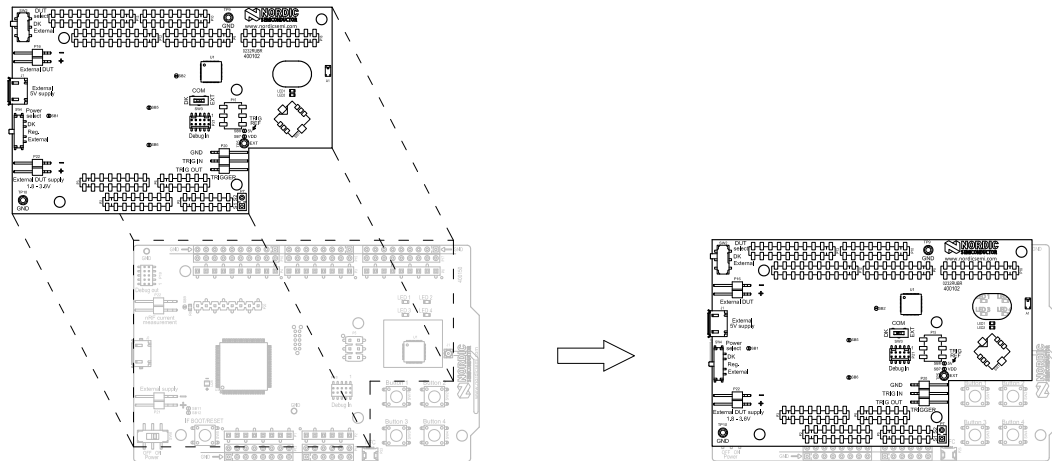

Figure 8: Connecting the PPK to the nRF5 DK

6.3 Measuring current on nRF5 DK

This setup is to be used during the design phase when custom hardware is not available yet.

For the PPK, this is a typical configuration that allows quick setup and current measurements in reference applications from the SDK or in custom applications.

In this case, the connection to the Power Profiler application is provided by the SEGGER J-Link on the nRF5 DK with a power supply applied on the DK. The configuration for this use case is shown in the following figure.

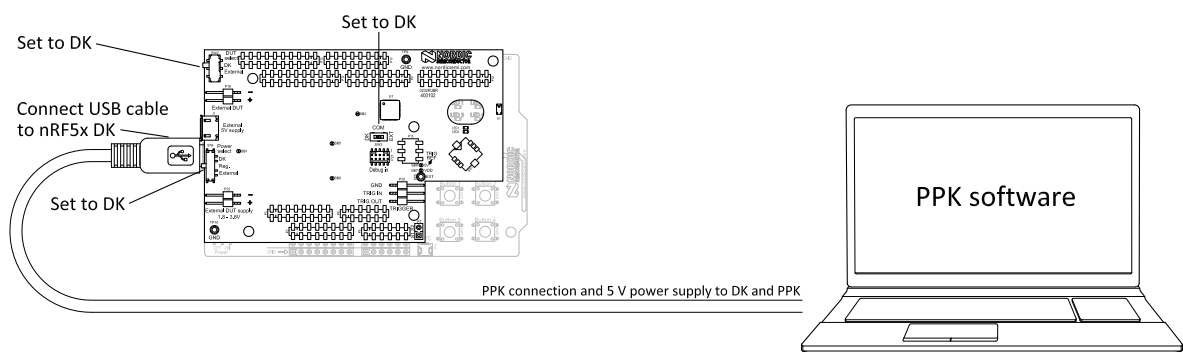

Figure 9: Measuring current on the nRF5 DK

Make sure that the following are configured:

- The PPK board (PCA63511) is connected to the nRF5 DK board as described in [Connecting Power Profiler Kit to nRF5 DK](#) on page 18.

- The DUT select switch (**SW2**) is in the "DK" position.
- The Power select switch (**SW4**) is in the "DK" position.
- The COM switch (**SW3**) is in the "DK" position.
- The USB cable is plugged into the USB connector on the nRF5 DK and connected to a computer with the Power Profiler application.

6.4 Measuring current on nRF5 DK while debugging

This setup is to be used during the design and optimization phase when no custom hardware is available yet. The SEGGER J-Link debugger on the nRF5 DK is used for debugging.

Because the SEGGER J-Link of the nRF5 DK is used for debugging, an additional SEGGER J-Link is needed to connect the PPK to your computer. This could be either another nRF5 DK with an onboard SEGGER J-Link or a standalone SEGGER J-Link which can be purchased separately from [SEGGER J-Link Software](#).

Note: This feature is only supported by v1.1 of the Python-based PPK software when run on a standalone SEGGER J-Link.

The configuration for this use case is shown in the following figure.

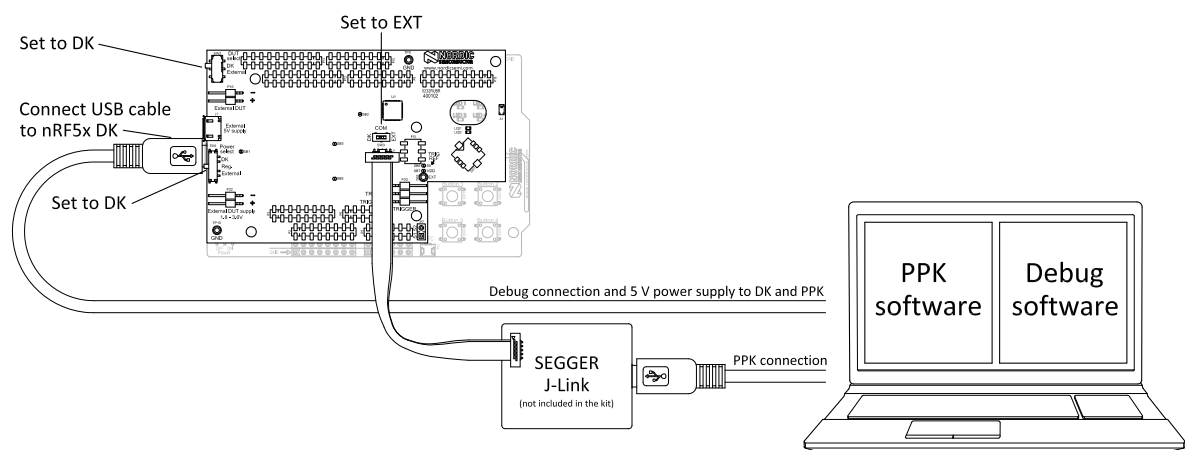

Figure 10: Measuring current on the nRF5 DK with debugging

Make sure that the following are configured:

- The PPK board (PCA63511) is connected to the nRF5 DK board as described in [Connecting Power Profiler Kit to nRF5 DK](#) on page 18.
- The DUT select switch (**SW2**) is in the "DK" position.
- The Power select switch (**SW4**) is in the "DK" position.
- The USB cable is plugged into the USB connector on the nRF5 DK and connected to a computer running the debugging software.
- The additional SEGGER J-Link is connected to the Debug in connector (**P21**) on the PPK, using the 10-pin flat cable. The USB cable is plugged into the SEGGER J-Link and connected to a computer running the Power Profiler application.
- The COM switch (**SW3**) is in the "EXT" position.

Note: Power consumption may be higher for devices during debugging than in normal operation. The difference depends on what is active at any given time. This is caused by the clocking of the debug interface and constantly powering sections of the device that are independent of the operation of the part. When debugging, accurate power consumption cannot be measured, but software issues can be detected.

6.5 Measuring current on custom hardware with nRF5 DK

This setup is to be used during the design phase on custom hardware acting as the device under test (DUT) with the nRF5 DK.

In this use case, the PPK measures the current on the external DUT. The PPK is connected to the nRF5 DK which is used as a SEGGER J-Link interface to the computer running the Power Profiler application.

The power supply is provided either by the PPK onboard regulator, or an external power source. See the figures below.

The power supply is applied to the nRF5 DK, which in turn powers the PPK board. This is used to supply power to the onboard analog measurement circuitry and the onboard regulator with 5 V. This will supply the external DUT when using the onboard regulator. If an external power source is used to supply the custom hardware, the USB connection will still be needed to supply the measurement circuitry of the PPK.

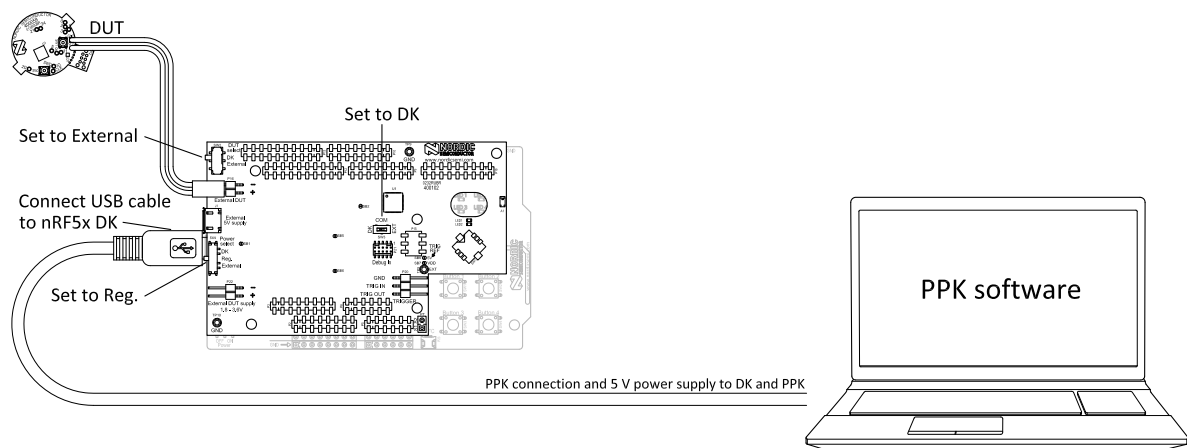

Figure 11: Measuring current on custom hardware with the onboard regulator as the power source and the nRF5 DK

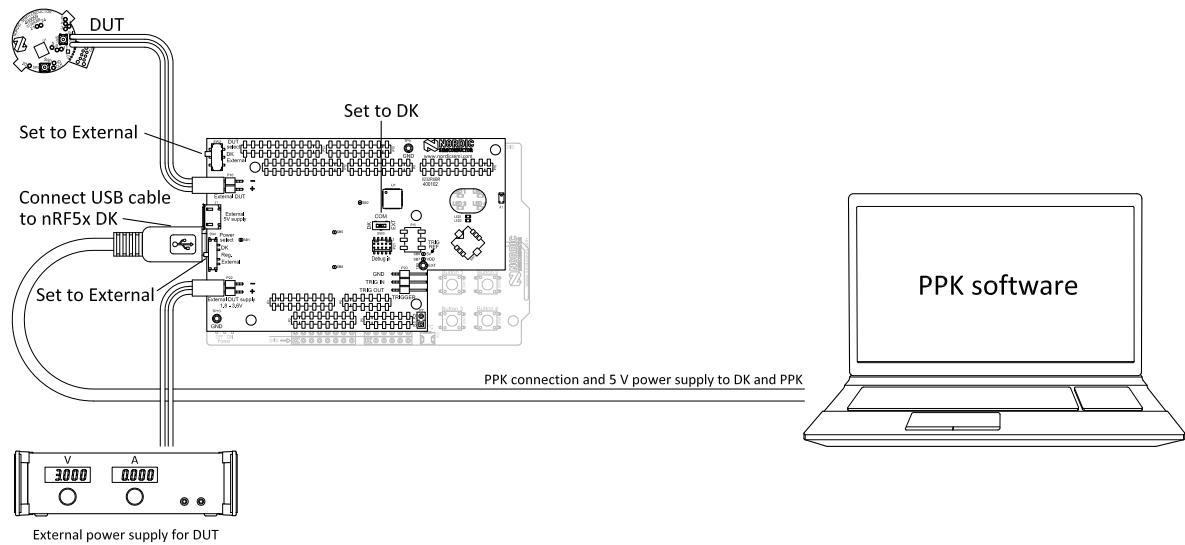

Figure 12: Measuring current on custom hardware with an external power source and the nRF5 DK

Make sure that the following are configured:

- The PPK board (PCA63511) is connected to the nRF5 DK board as described in [Connecting Power Profiler Kit to nRF5 DK](#) on page 18.
- The USB cable is plugged into the USB connector on the nRF5 DK and connected to a computer running the Power Profiler application.
- The DUT select switch (**SW2**) is in the "External" position.
- The custom hardware is connected to the External DUT connector (**P16**) of the PPK.
- The power source is one of the following:
 - The PPK onboard regulator: Set the Power select switch (**SW4**) in the "Reg" position.
 - External power supply: In addition to the USB cable plugged into the nRF5 DK, make sure that the external power is connected to the External DUT supply connector (**P22**) of the PPK (voltage range from 1.8 V to 3.6 V). Set the Power select switch (**SW4**) in the "External" position.
- The COM switch (**SW3**) is in the "DK" position.

6.6 Measuring current on custom hardware without nRF5 DK

This setup is to be used during the design phase on custom hardware without using the nRF5 DK. This feature is only supported by v1.1 of the Python-based PPK software when run on a standalone SEGGER J-Link.

The power supply is provided either by the PPK onboard regulator or an external power source. See the figures below.

The External 5V supply USB connector (**J1**) of the PPK is used to supply power to the onboard analog measurement circuitry and the onboard regulator with 5 V. This will supply the custom hardware (DUT). If an external power source is used to supply the custom hardware, the USB connection will still be needed to supply the measurement circuitry of the PPK.

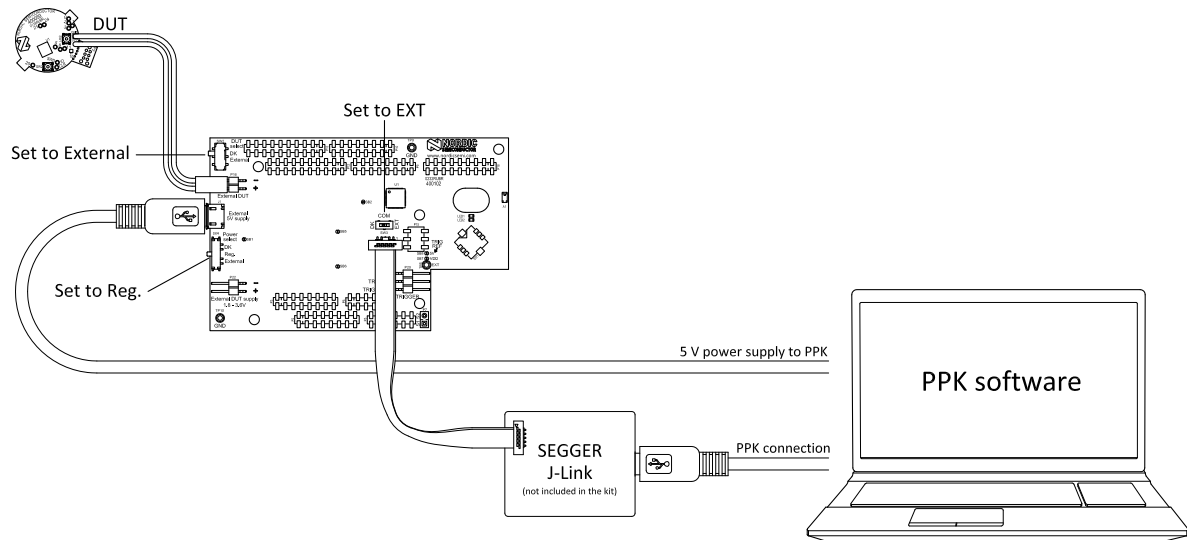

Figure 13: Measuring current with the onboard regulator as the power source without an nRF5 DK

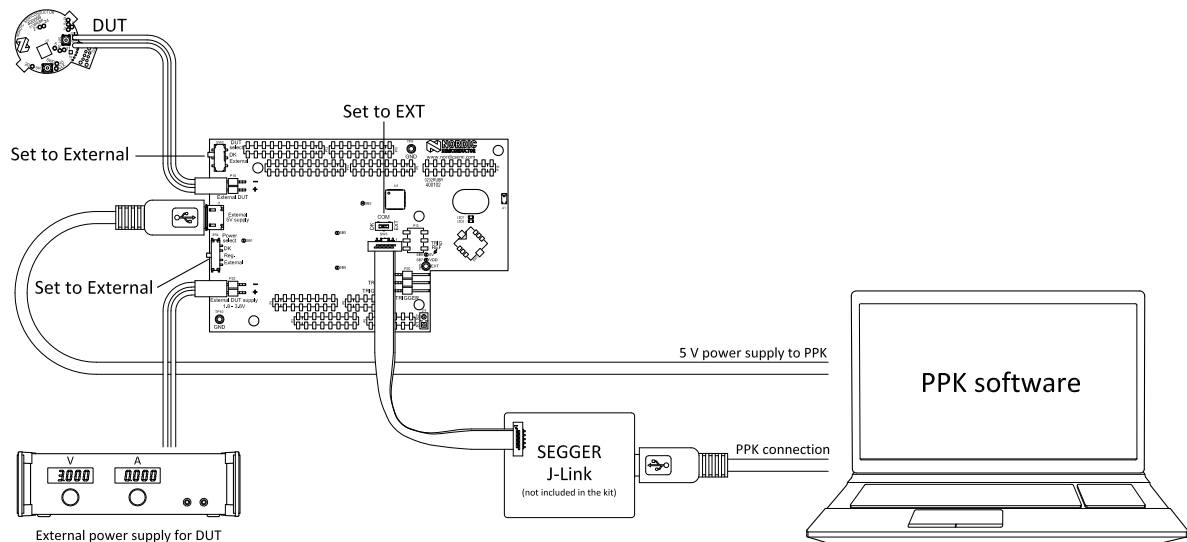

Figure 14: Measuring current with an external power source without an nRF5 DK

Make sure that the following are configured:

- The DUT select switch (**SW2**) is in the "External" position.
- The custom hardware (DUT) is connected to the External DUT connector (**P16**) of the PPK.
- The power source is one of the following:
 - The PPK onboard regulator: Make sure that a USB cable with power is plugged into the External 5V supply USB connector (**J1**) of the PPK. Set the Power select switch (**SW4**) in the "Reg" position.
 - External power supply: In addition to the USB cable plugged into the External 5V supply USB connector (**J1**), make sure that the external power is connected to the External DUT supply connector (**P22**) of the PPK (voltage range from 1.8 V to 3.6 V). Set the Power select switch (**SW4**) in the "External" position.
- The additional SEGGER J-Link is connected to the Debug in connector (**P21**) on the PPK using the 10-pin flat cable. The USB cable is plugged into the SEGGER J-Link and connected to a computer running the Power Profiler application.
- The COM switch (**SW3**) is in the "EXT" position.

7 Connecting Power Profiler Kit to a computer

You need to connect the Power Profiler Kit (PPK) to a computer with a USB cable in order to use it.

1. Connect the PPK to your computer using a USB cable.
 - If the PPK is connected to an nRF5 DK, connect the USB cable to the nRF5 DK.
 - If the PPK is running standalone, connect the USB cable to the PPK (**J1**). See [Figure 6: PPK connectors](#) on page 13.
2. If you are using an external SEGGER J-Link in your configuration, use a USB cable to connect it to your computer.
3. If you are using the nRF5 DK, slide the nRF5 power switch to "ON".
If Windows driver installation starts for the inserted DK, wait until it finishes before continuing.
4. Verify that the **LED2** is lit on the PPK.

Your PPK is now connected to the computer. You are ready to start the Power Profiler application.

8 Installing Power Profiler Kit software package

The Power Profiler Kit (PPK) software package is installed using nRF Connect.

Before you start, check [Minimum requirements](#) on page 6.

1. Open nRF Connect.
2. Click **Add/remove apps**.
3. Click **Install**.

For information about using the software, see [Using Power Profiler Kit application](#) on page 25.

9 Using Power Profiler Kit application

The Power Profiler Kit (PPK) must be configured correctly, connected to your computer, and powered before the Power Profiler application can be started.

1. Start the Power Profiler application using nRF Connect.



Figure 15: Settings and Plots view in the Power Profiler application

2. Click **Select serial port** (in the top left corner) and select the serial number corresponding to the connected DK.

After some initial set-up, the **Start** button changes color, and you can start measuring current.

The application will check if the required firmware is present and show a firmware upgrade dialog if needed.

To show advanced controls for switch levels and resistor calibration, press **CTRL+ALT+SHIFT+A**.

10 Electrical specifications

These specifications contain the property values that are essential for using the Power Profiler Kit (PPK).

10.1 Environmental specifications

These environmental specifications contain the values that are essential for using the Power Profiler Kit (PPK).

Item	Name	Min	Typ	Max	Unit	Description
Operating temperature	Op_Temp	15		30	°C	

Table 4: Environmental specifications

10.2 Power supply specifications

These power supply values are essential for using the Power Profiler Kit (PPK).

Item	Name	Min	Typ	Max	Unit	Description
DUT voltage	VDD_DUT	1.8		3.6	V	
External supply voltage	VDD_EXT	1.8		3.6	V	
Micro-USB supply voltage	V5V	4.5		5.5	V	USB voltage tolerances

Table 5: Power supply specifications

10.3 Measurement specifications

These measurement specifications contain the property values that are essential for using the Power Profiler Kit (PPK).

10.3.1 Maximum DUT admissible current

The maximum DUT admissible current specification contains the value that is essential for using the Power Profiler Kit (PPK).

Item	Name	Min	Typ	Max	Unit	Description
Maximum DUT admissible current	Max_I			70	mA	

Table 6: Maximum DUT admissible current

10.3.2 Measurement resolution

These measurement resolution values are essential for using the Power Profiler Kit (PPK).

Item	Name	Min	Typ	Max	Unit	Description
1–70 μ A range	R1_Resol		0.2		μ A	
70 μ A–1 mA range	R2_Resol		3		μ A	
1–70 mA range	R3_Resol		50		μ A	

Table 7: Measurement resolution

10.3.3 Measurement accuracy

These measurement accuracy values are essential for using the Power Profiler Kit (PPK).

Item	Name	Min	Typ	Max	Unit	Description
1–70 μ A range	R1_Accuracy		+/- 20		%	Readout on Average value
1–70 μ A range	R1_Offset		\pm 2		R1_Resol	
70 μ A–1 mA range	R2_Accuracy		+/- 15		%	Readout on Average value
70 μ A–1 mA range	R2_Offset		\pm 2		R2_Resol	
1–70 mA range	R3_Accuracy		+/- 15		%	Readout on Average value
1–70 mA range	R3_Offset		\pm 2		R3_Resol	
Sampling rate	Meas_Frequency		77		kHz	Fixed value

Table 8: Measurement accuracy

11 Troubleshooting

Here are some basic troubleshooting steps to help you fix issues you may encounter when using the Power Profiler Kit (PPK).

PPK only measuring noise

Make sure you have prepared the nRF5 DK for current measurements by cutting the nRF current measurement solder bridge as described in:

- Section *Preparing the development kit board* in [nRF51 Development Kit User Guide](#)
- [Preparing the development kit board](#) in nRF52 DK User Guide
- [Preparing the development kit board](#) in nRF52840 PDK User Guide

Measurements fluctuate when there should be a steady current draw

Your DUT may have a power consumption that is close to a switching point causing rapid switching between the ranges and creating measurement errors/distorted plots. Try adjusting the switching points.

The graph response is very slow

Avoid using USB hubs and docking stations. Also, if the trigger window is receiving a lot of updates, consider stopping this plot to have better throughput for the **Average** plot.

For more information, visit [Nordic Developer Zone](#).

For personalized support from our technical support team, sign up for or sign in to [Nordic Developer Zone](#) and enter a private ticket.

Legal notices

By using this documentation you agree to our terms and conditions of use. Nordic Semiconductor may change these terms and conditions at any time without notice.

Liability disclaimer

Nordic Semiconductor ASA reserves the right to make changes without further notice to the product to improve reliability, function or design. Nordic Semiconductor ASA does not assume any liability arising out of the application or use of any product or circuits described herein.

All information contained in this document represents information on the product at the time of publication. Nordic Semiconductor ASA reserves the right to make corrections, enhancements, and other changes to this document without notice. While Nordic Semiconductor ASA has used reasonable care in preparing the information included in this document, it may contain technical or other inaccuracies, omissions and typographical errors. Nordic Semiconductor ASA assumes no liability whatsoever for any damages incurred by you resulting from errors in or omissions from the information included herein.

Life support applications

Nordic Semiconductor products are not designed for use in life support appliances, devices, or systems where malfunction of these products can reasonably be expected to result in personal injury.

Nordic Semiconductor ASA customers using or selling these products for use in such applications do so at their own risk and agree to fully indemnify Nordic Semiconductor ASA for any damages resulting from such improper use or sale.

RoHS and REACH statement

Nordic Semiconductor products meet the requirements of *Directive 2011/65/EU of the European Parliament and of the Council on the Restriction of Hazardous Substances (RoHS 2)* and the requirements of the *REACH* regulation (EC 1907/2006) on Registration, Evaluation, Authorization and Restriction of Chemicals.

The SVHC (Substances of Very High Concern) candidate list is continually being updated. Complete hazardous substance reports, material composition reports and latest version of Nordic's REACH statement can be found on our website www.nordicsemi.com.

Trademarks

All trademarks, service marks, trade names, product names and logos appearing in this documentation are the property of their respective owners.

Copyright notice

© 2018 Nordic Semiconductor ASA. All rights are reserved. Reproduction in whole or in part is prohibited without the prior written permission of the copyright holder.

