

EvB 5.1 v5 User's Guide

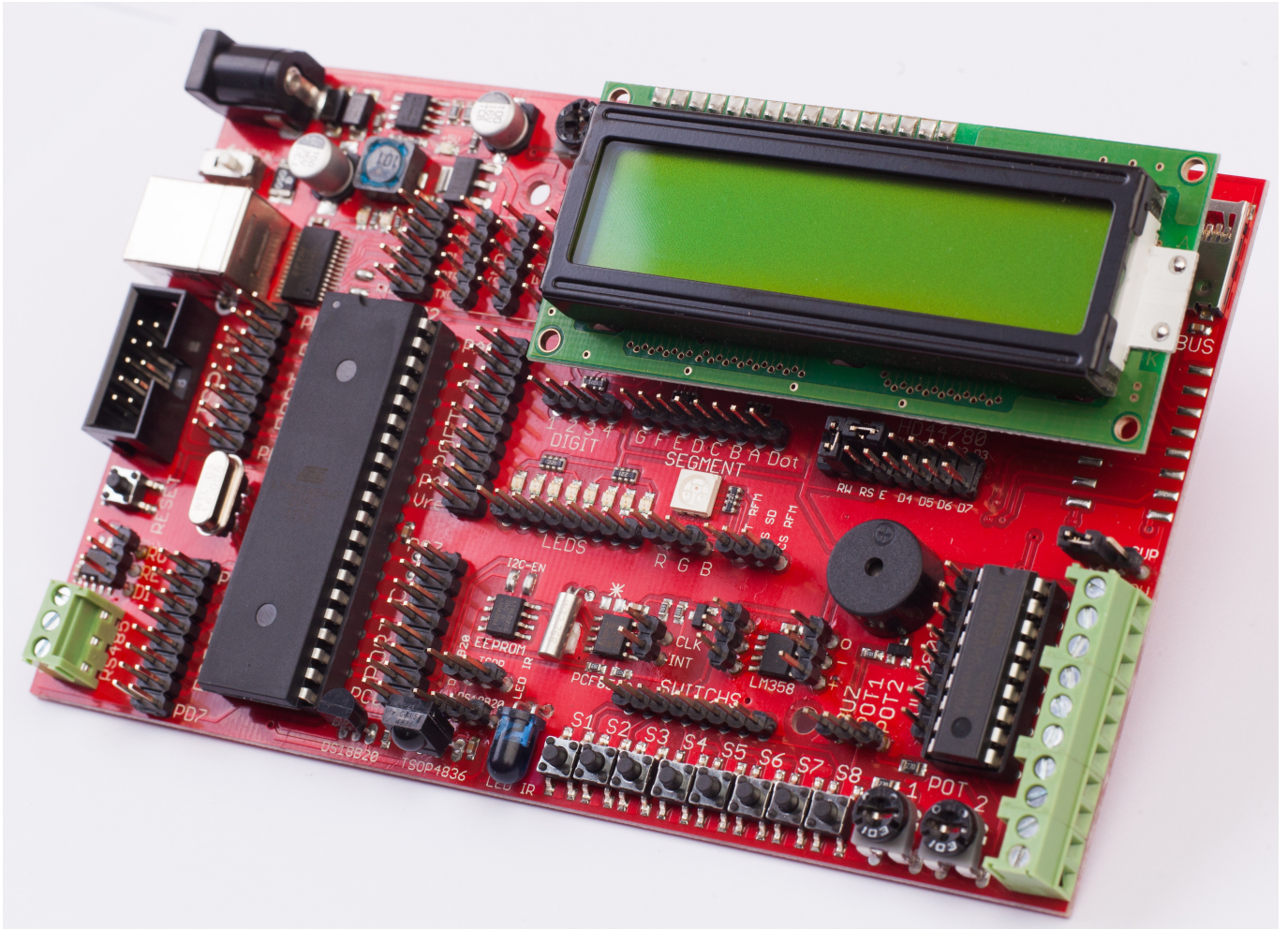

Contents

Introduction.....	4
The EvB 5.1 v5 kit.....	5
Power supply.....	6
Programmer's connector.....	7
USB Port.....	8
RS485 Port.....	9
LED's.....	10
Pushbuttons.....	11
Potentiometers and Buzzer.....	12
Power outputs	13
RTC clock and EEPROM memory.....	14
MMC/SD card.....	15
LED display.....	16
LCD display.....	17
IR receiver, temperature detector	18
uC pins.....	19
Programming via USB.....	21
Programming the AVR microprocessor.....	24
with the EVB kit 4.3.....	24
Combining sets of EvB 5.1 BASCOM Environment.....	27
Combining sets of EvB 5.1 WinAVR Environment	28
Environmental Protection	30

Introduction

The EvB 5.1 is a launching set is based on two types of popular Atmel's microprocessors ATmega16 and ATmega32.

The board is equipped with a number of peripheral elements which endings are connected to the pin header that enables user to quick implementation of any project without a need to perform a dedicated board. All headers are labelled, situated near and connected close to peripherals. It enables to intuitive connection elements without a need to read the documentation.

The EvB 5.1 set has been designed both for non-experienced users who make their first steps in the world of microprocessors and for those professional programmers who search a universal platform for their projects.

Earlier versions of the EvB4.3 board were successfully applied for a number of major projects at Polish universities and during the diploma scientific researches. Nowadays our boards are in use at the universities of Silesia region.

The EvB 5.1 v5 kit

The EvB 5.1 v5 kit includes:

- Board equipped with the following units:
 - AVR ATmega32 or ATmega644p Processor with DIP40 body
 - Real time clock PCF8563
 - EEPROM AT24C02 memory
 - TSOP4836 infra-red receiver
 - Infra-red transmitter
 - DS18B20 temperature detector
 - RS485 converter
 - micro SD card socket
 - 8 push buttons
 - 8 LEDs
 - RGB led
 - 8 transistor outputs of 500mA each
 - 2 analogue potentiometers
 - 4x7 segment display
 - USB port
 - ISP port
 - 5 pins of voltage +5V
 - 5 pins of voltage +3.3V
 - 5 pins of mass
- LCD of 2x16 characters
- A set of connection tools (4 single cables - 10cm, one 8-line cable of 10cm)

Programmer's connector

At the EvB 5.1 board a 10-pin programmer's connector is set in the ISP KANDA standard. The connector is compatible with the most of programmers available at the market, including the STK200 and AVRProg.

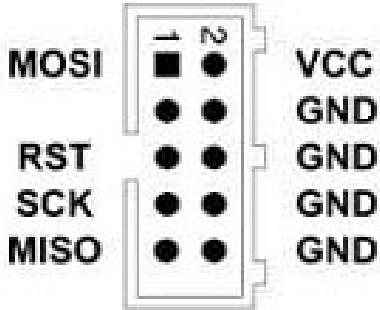

- MOSI, MISO, SCK ISP data way signals
- RST Destination system reset
- NC Not connected
- VCC Destination system voltage

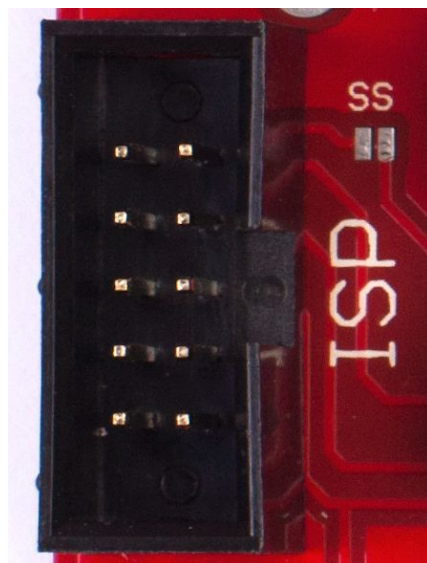
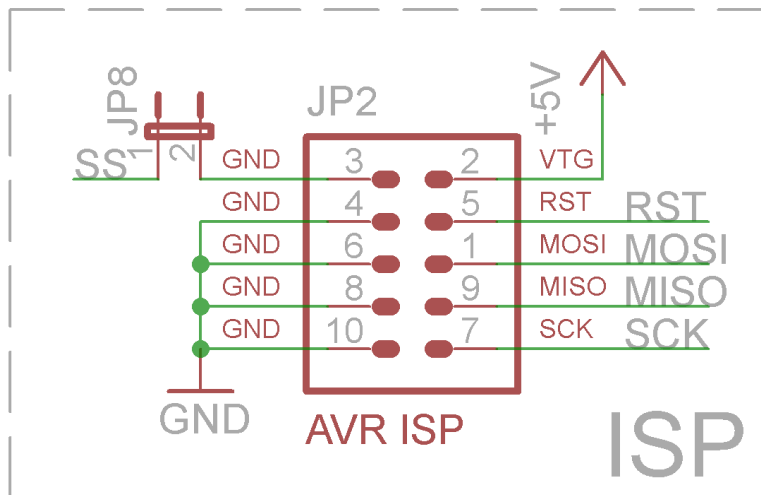

USB Port

Communication of the EvB 5.1 set with a PC has been designed to use a USB-UART FT232RL converter (a virtual COM port). The system FT232RL is connected to TXD and RXD lines of the processor that leave no need for its connecting.

A virtual COM port drivers are available at:

<http://www.ftdichip.com/Drivers/VCP.htm>

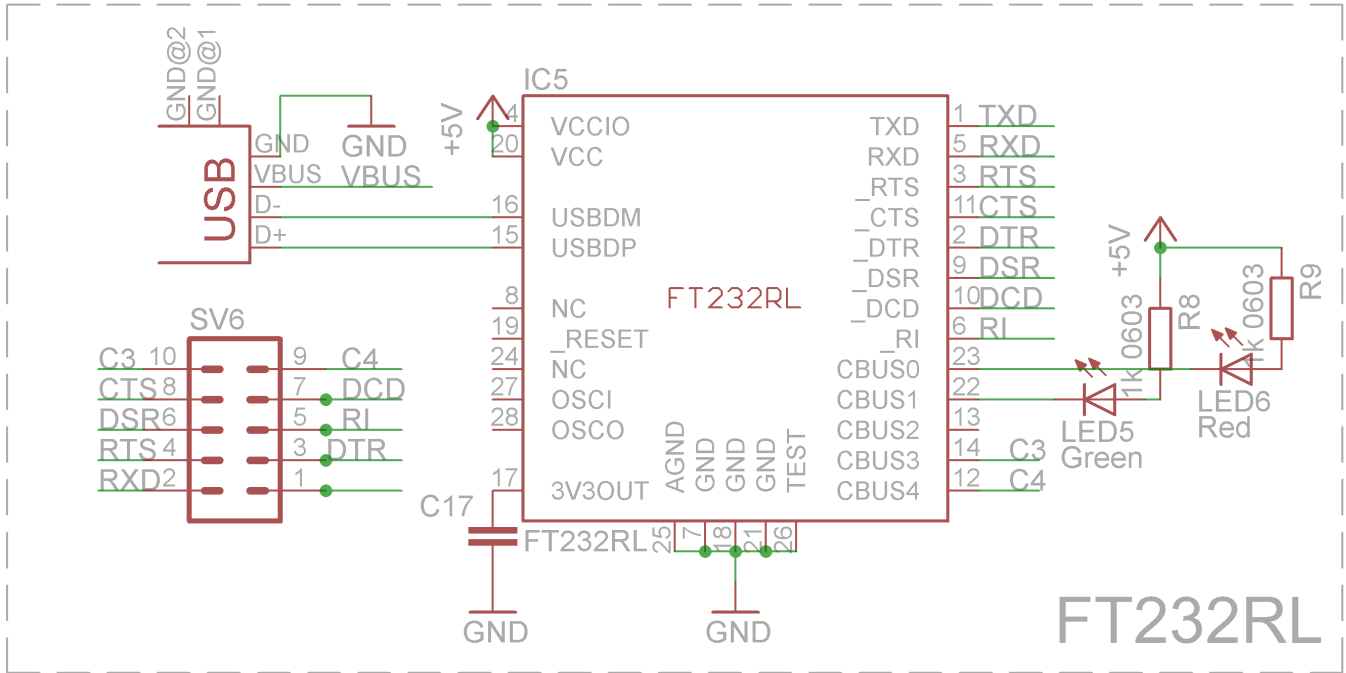

In addition, the system FT232RL lines were derived TXD, RXD, C3, C4, CTS, DSR, RTS, DCD, RI, DTR to the gold pins. These lines are used for emergency programming microprocessor but can also be used for any purpose.

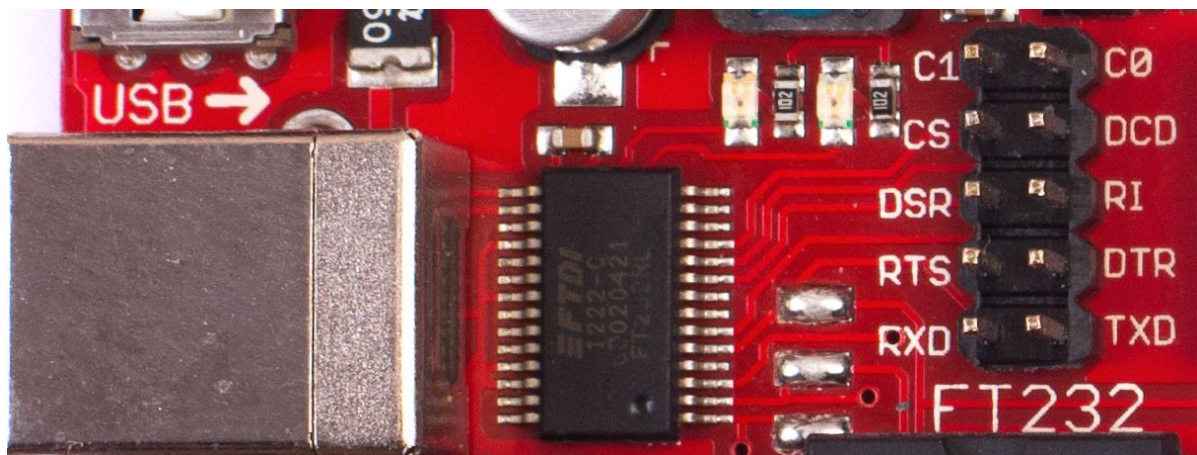

RS485 Port

The EvB 5.1 board is equipped with a RS485 industrial data way enabling the board to be used in various industrial applications. Data lines (A and B) has been directed onto a terminal block situated in the left-bottom corner of the board. The 120R jumper is responsible for a connection of line terminator.

Pins RO, DI and the combined RE and DE were derived on a gold pin.

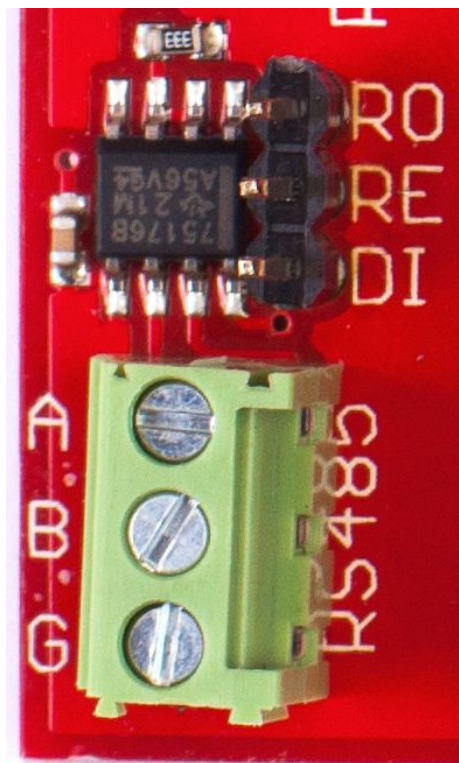
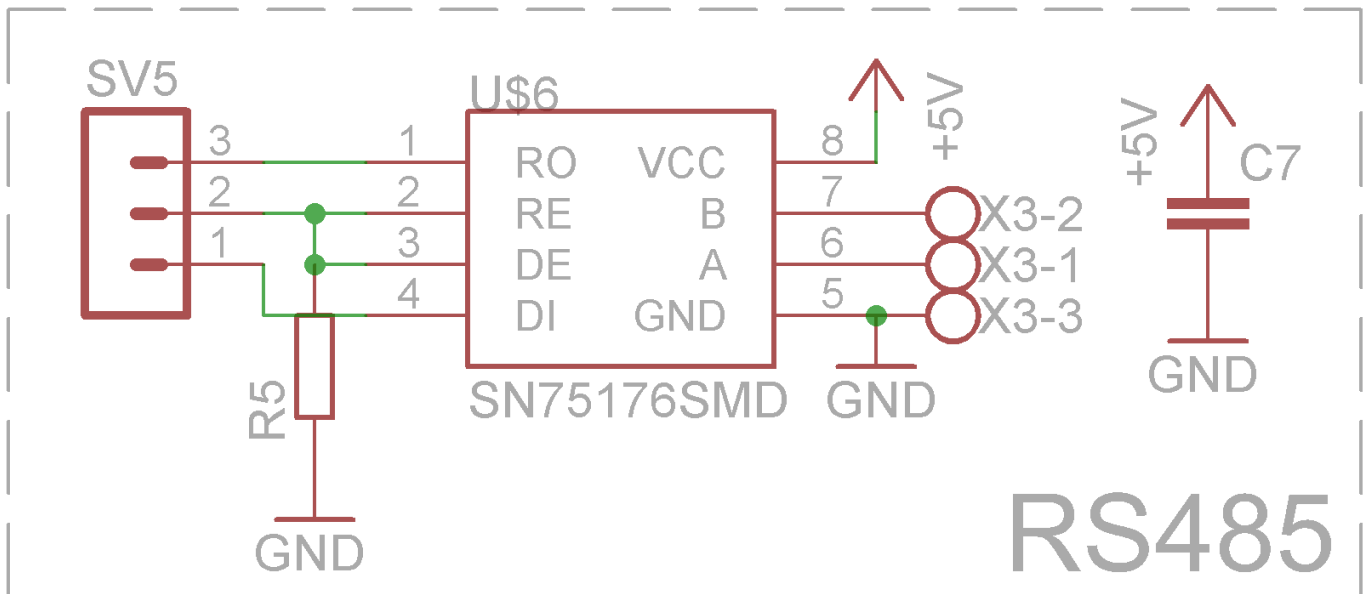

LED's

To lit a LED situated on the board you will need to connect the mass (logic zero) to its pin.

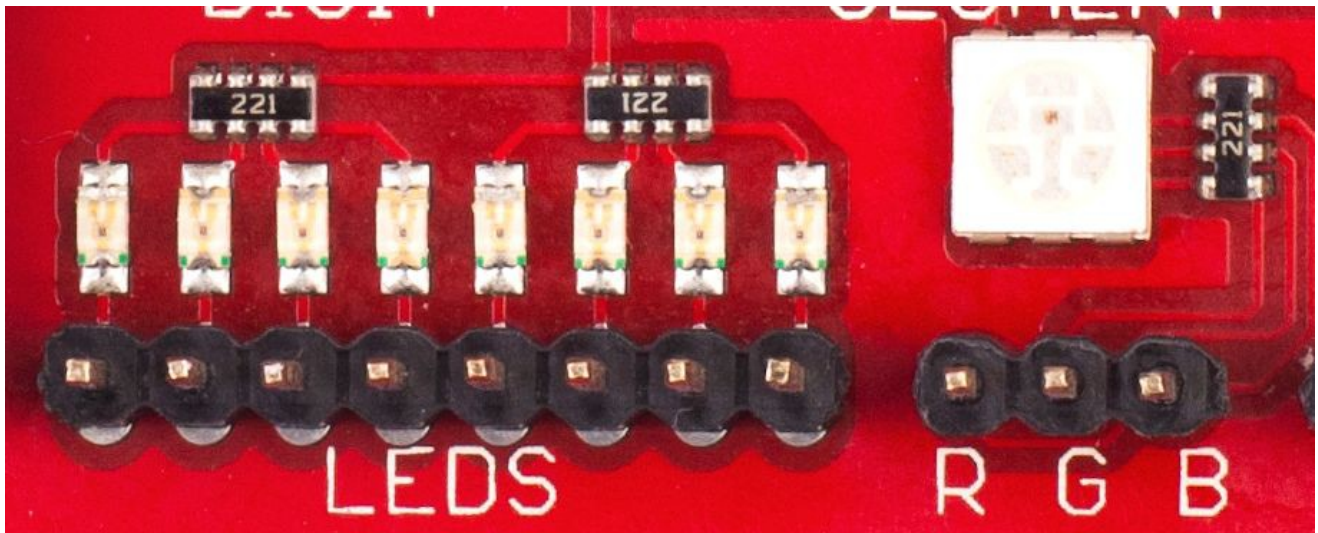
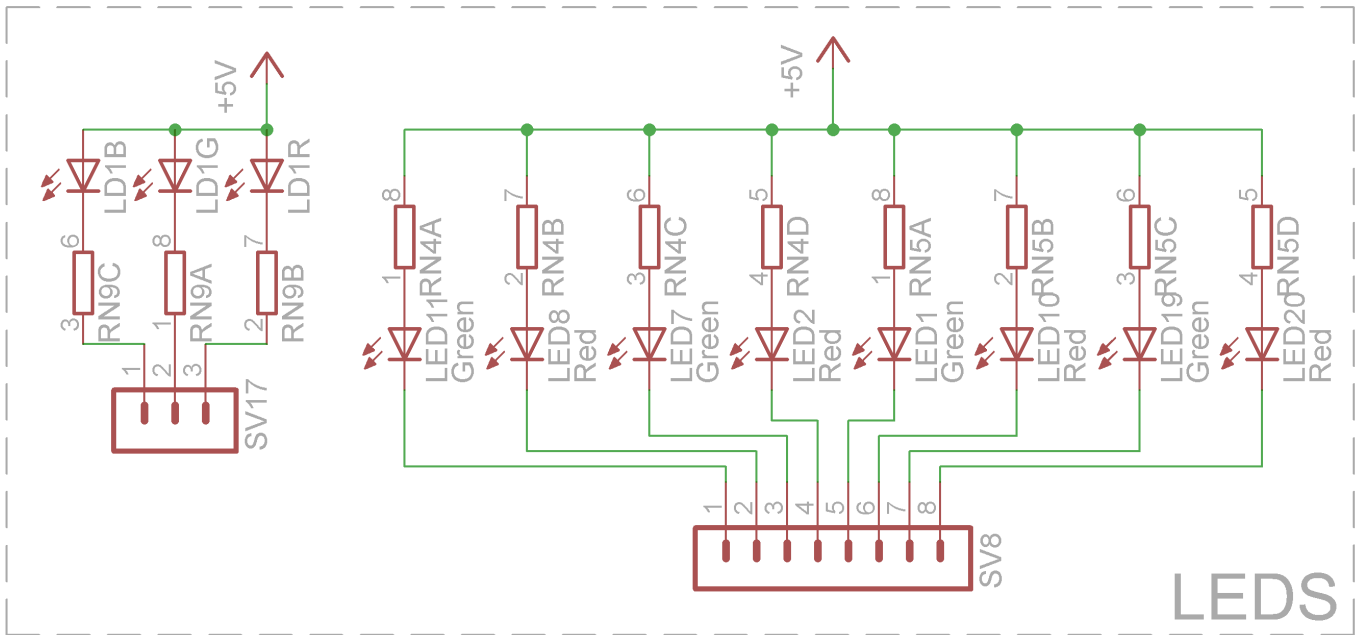

Pushbuttons

The pushbuttons situated at the board, when pressed connect their pins with the mass. To make the processor detect a pushbutton being pressed, apply a connecting pull-up resistor.

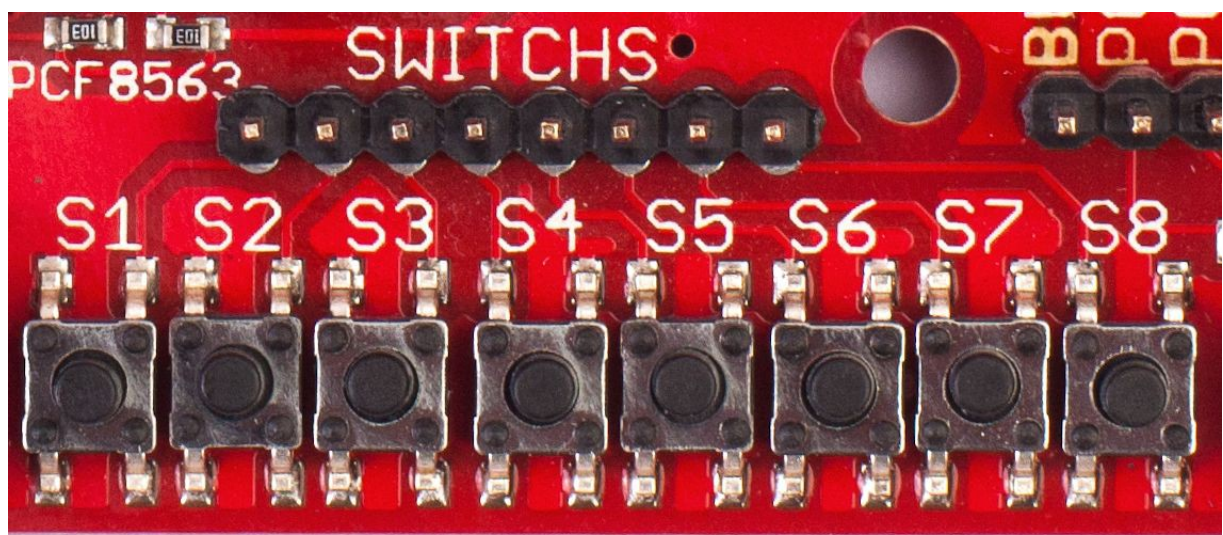
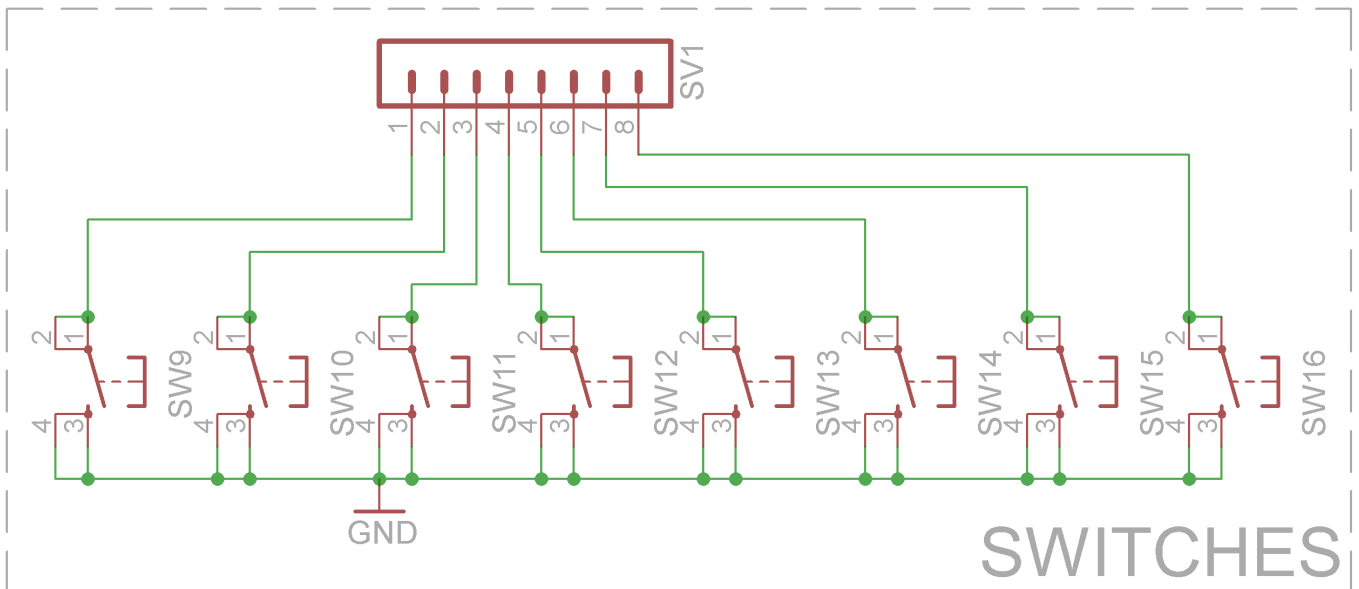

Power outputs

The board is equipped with two outputs of 1A each (green one) and three outputs of 500mA each. The upper output marked with + is the voltage from the external power pack (if connected). Other slots of the connector are connected to the mass after 5V (logic 1) being connected with referring outputs.

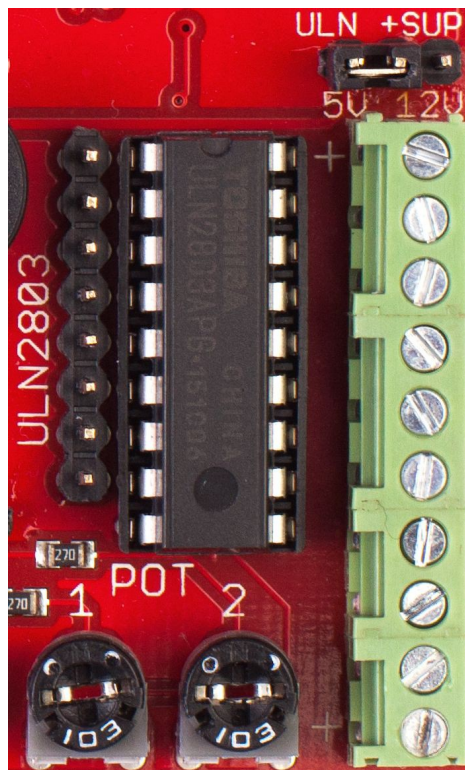
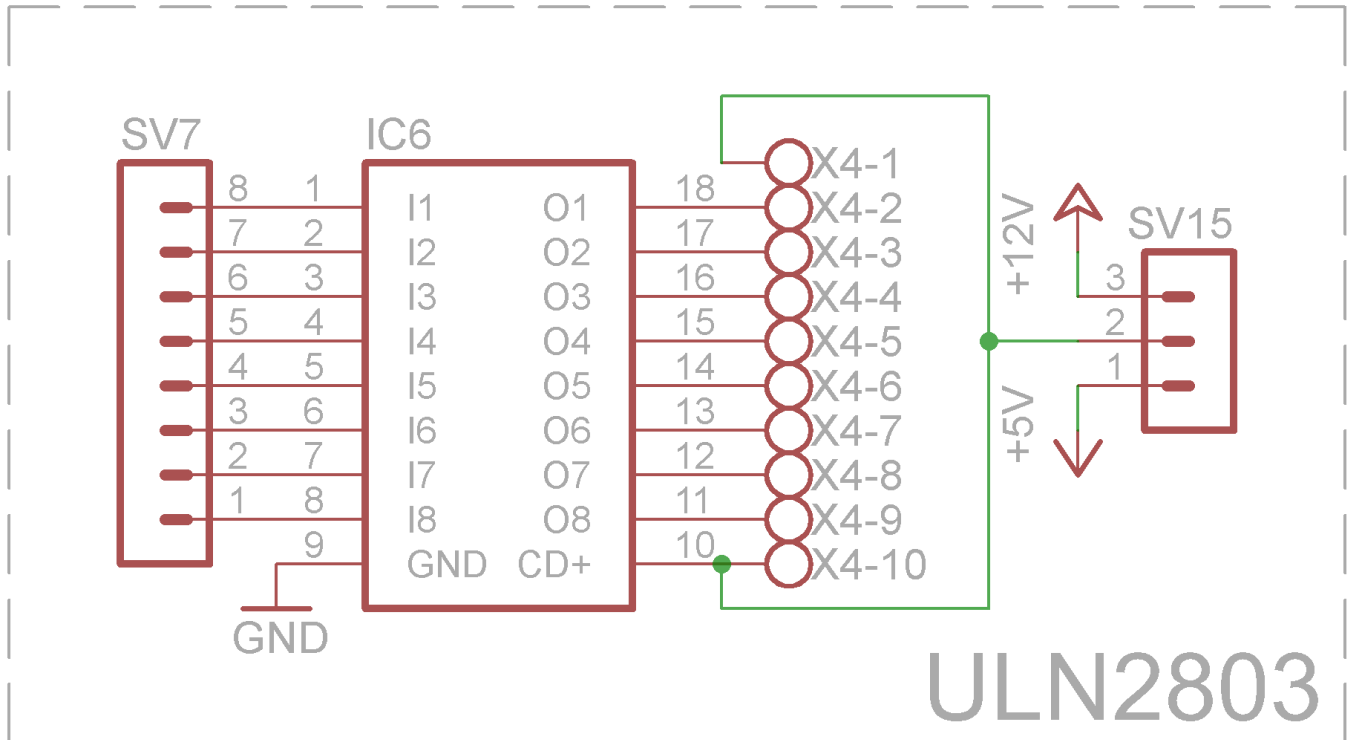

RTC clock and EEPROM memory

The board is equipped with two circuits using single data way 12C. The 2 kBits EEPROM memory (of the address 172 (0xAD) for reading and 173 (0xAC) for recording) and real time clock PCF8563 (of the address 162 (0xA2) for reading and 163 (0xA3) for recording). The PCF8563 circuit is connected with the INT pin responsible for breaks caused by alarm and a connector for battery power source for the clock. Battery can be also insert in socket on the bottom of boards.

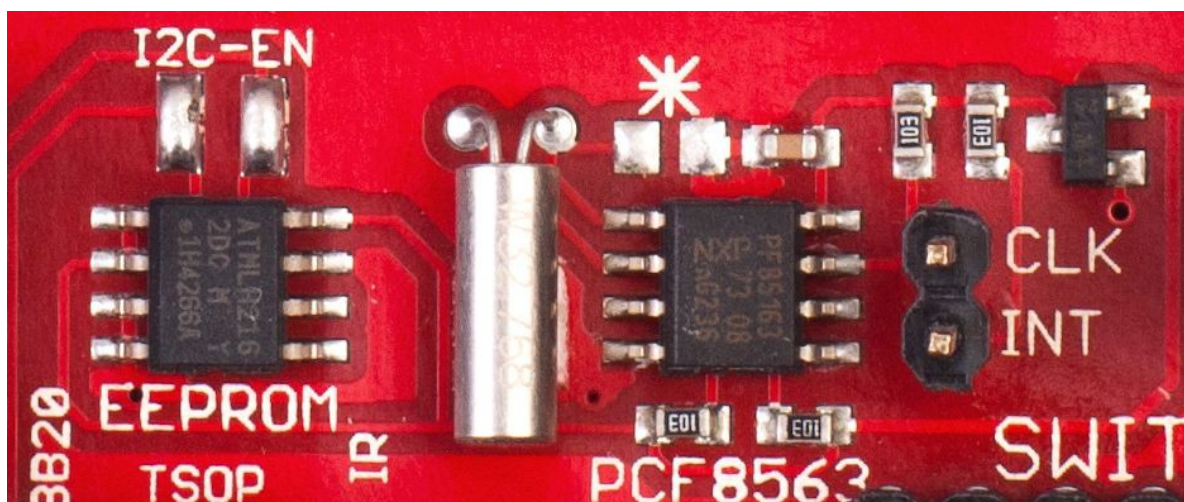
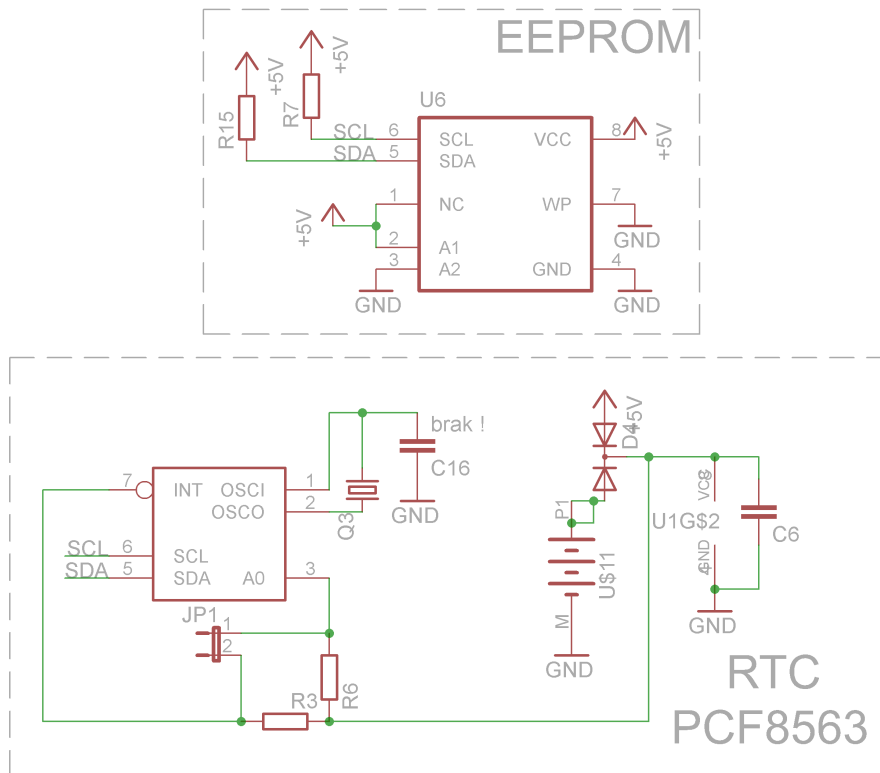

MMC/SD card

The board is equipped with a socket for external micro SD cards. The power source for these cards is a 3,3V external stabilizer. The signals are adjusted to the 5V voltage by the buffer and connected to uC SPI (except CS).

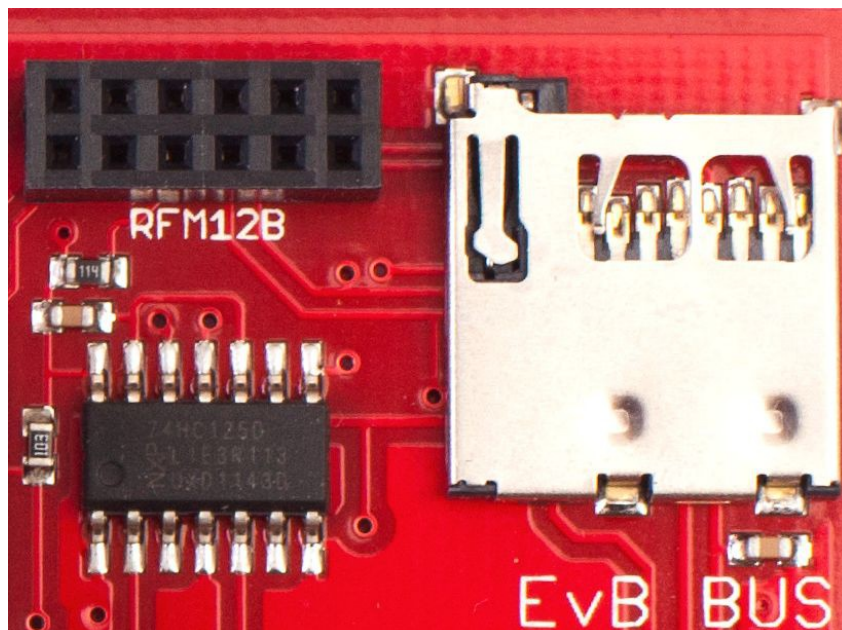
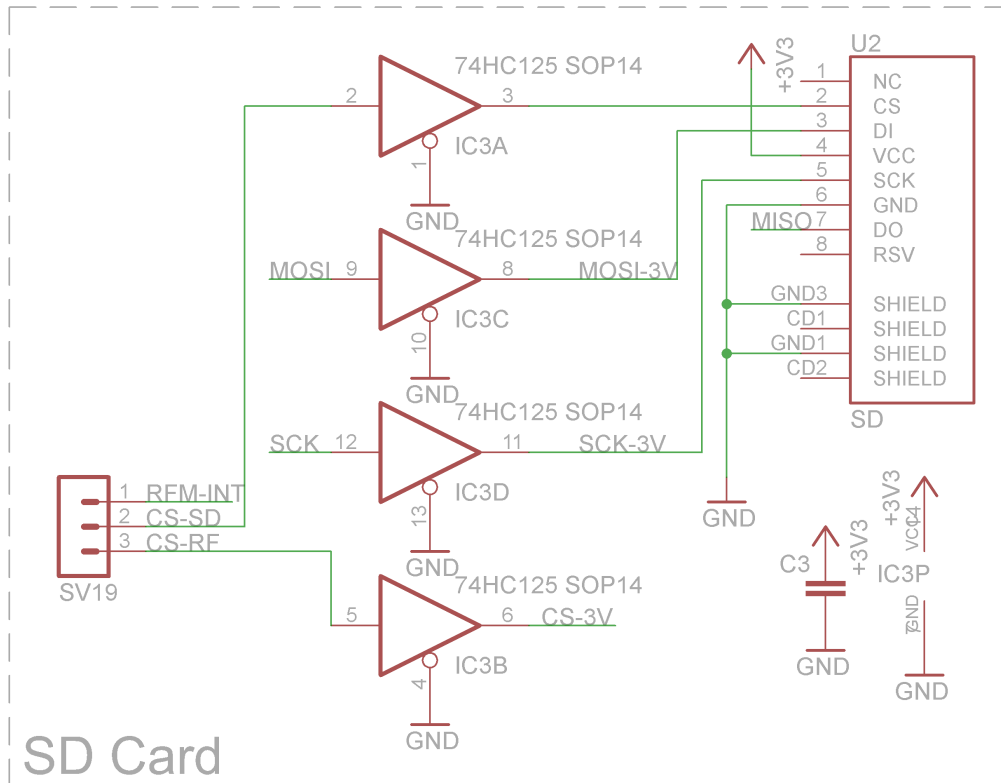

LED display

In order to lit a display segment, forward a logic zero to the transistor's base (DIGI pins) and to the Pin responsible for the exact display's (SEGMENT pins).

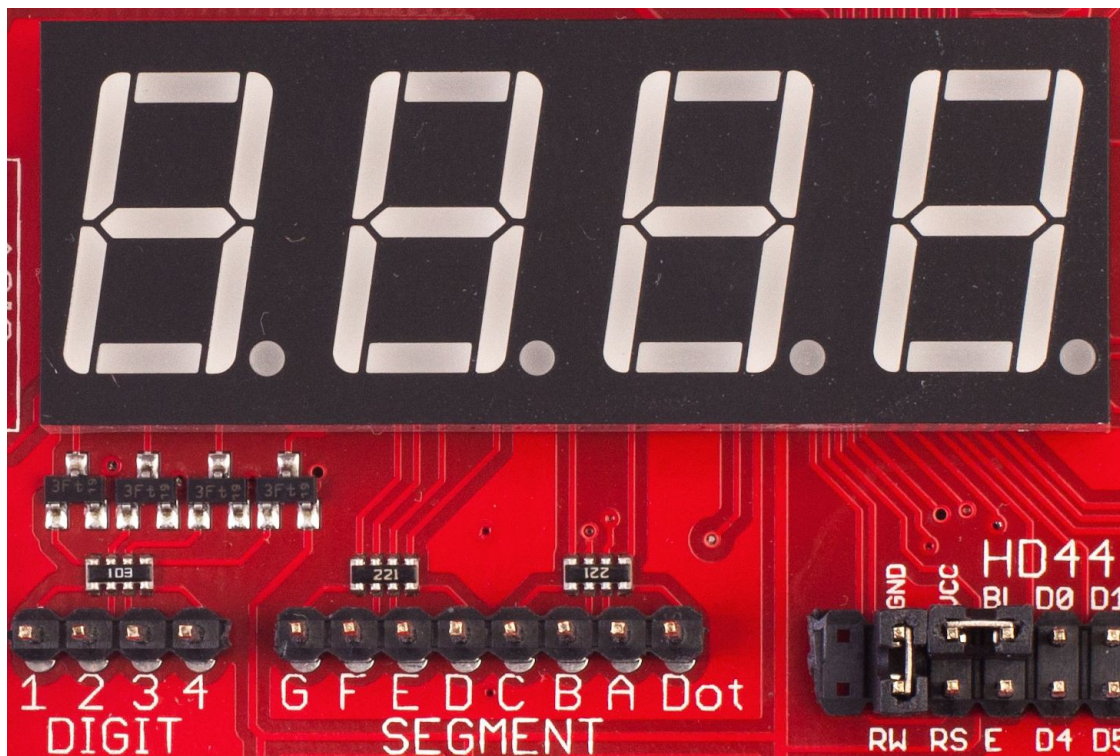
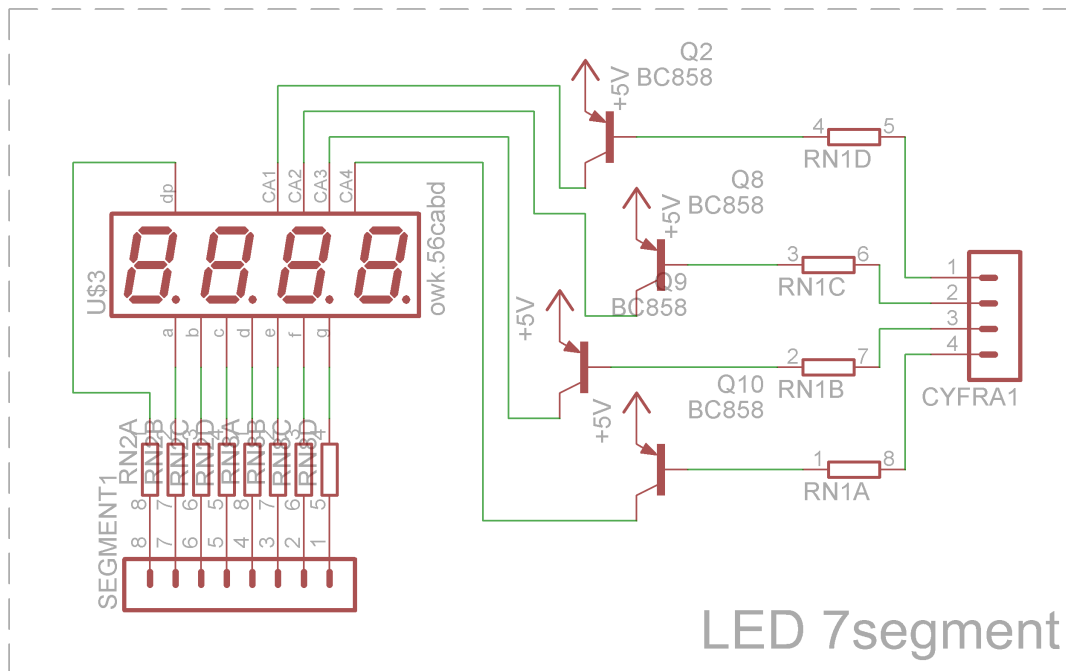

LCD display

A 16-pin connector for the LCD connection based on the HD44780 controller. Because of the electric connection, the display is being controlled using 4 or 8bit words. The display signals are connected with the HD44780 connector labelled underneath. The display's contrast may be adjusted by the potentiometer (marked at the drawing below).

Jumper mark as BL enable LCD BackLight (enable by +5V).

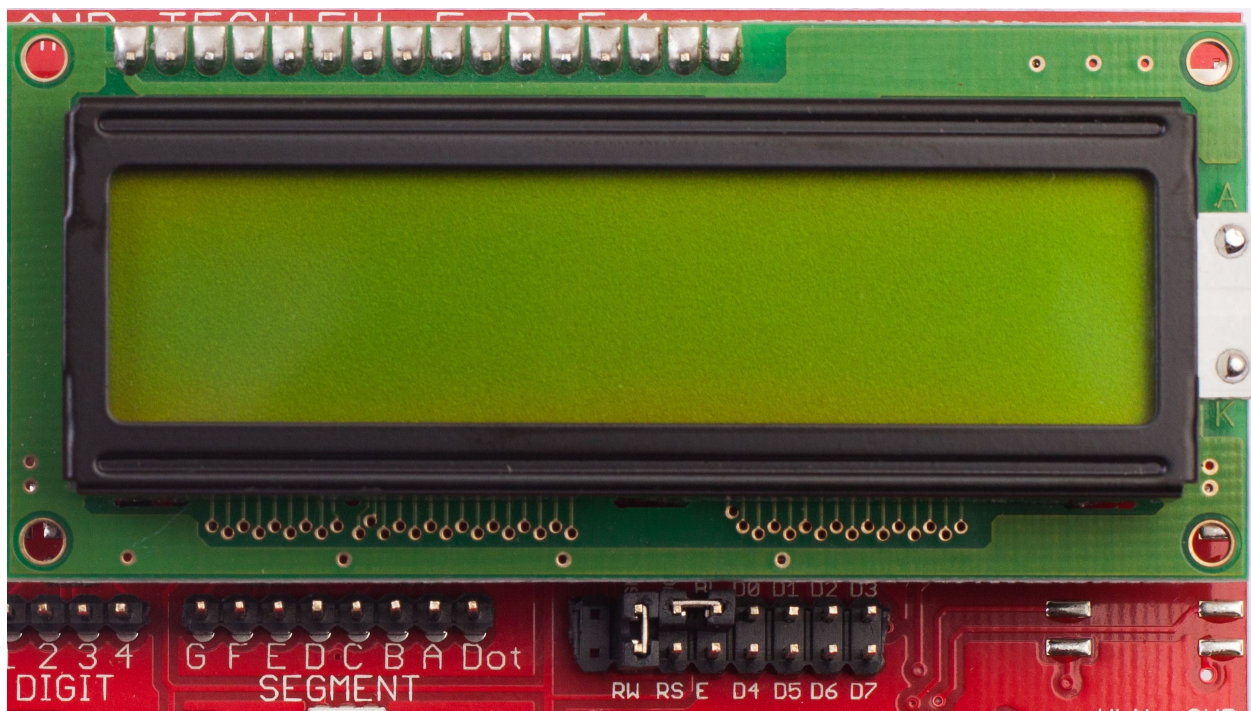
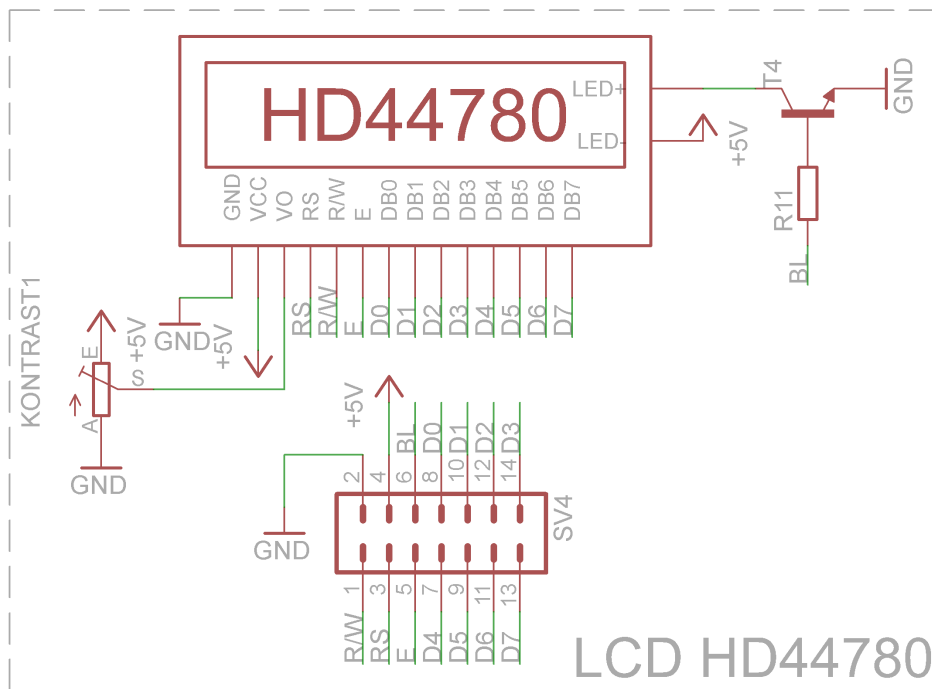

IR receiver, temperature detector

The TSOP4836 infra-red detector's signal and the signal of the temperature detector DS18B20, are available at the connector placed above the mentioned devices. The left pin is connected with the temperature detector and the right pin is connected with the receiver.

Additional temperature detectors may also be included and connected with the connector at the top of the detector. (star mark is the mass).

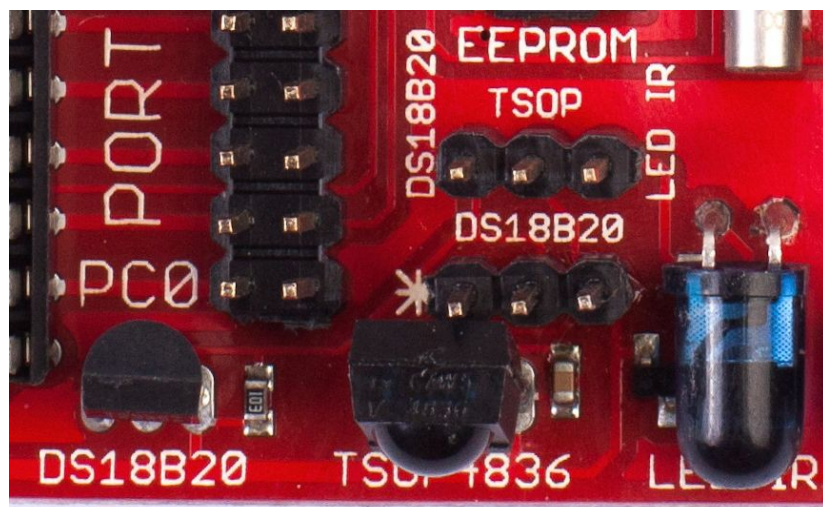
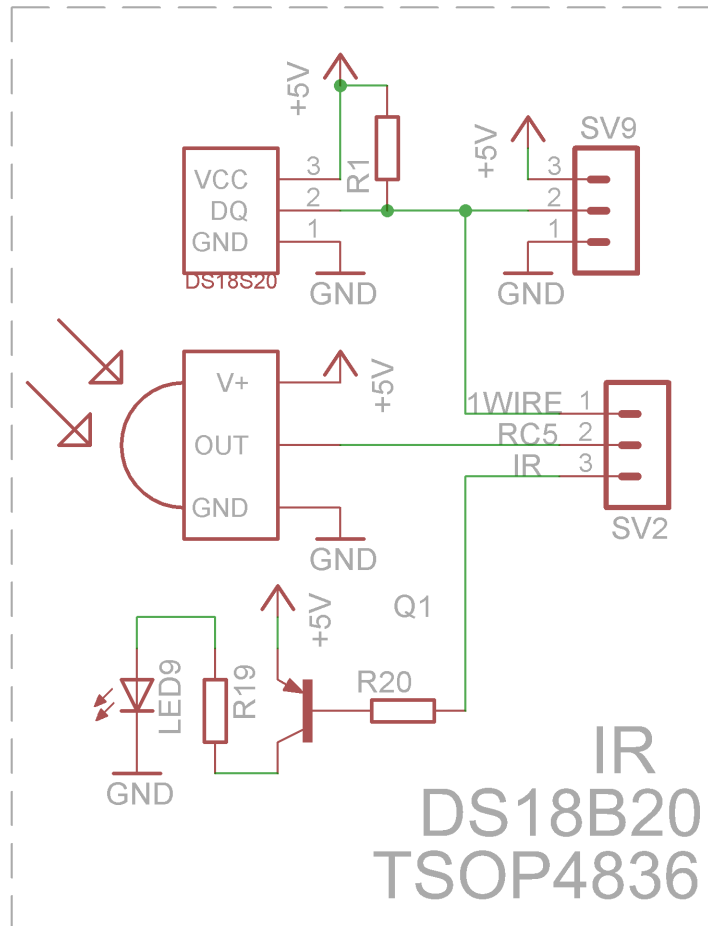

uC pins

All ports and the AREF pin (AC transducer's referential voltage) are connected to the processor's pins. All connections descriptions are available at the scheme below. The RESET button placed next to the USB port is designed for a hard reset of the circuit.

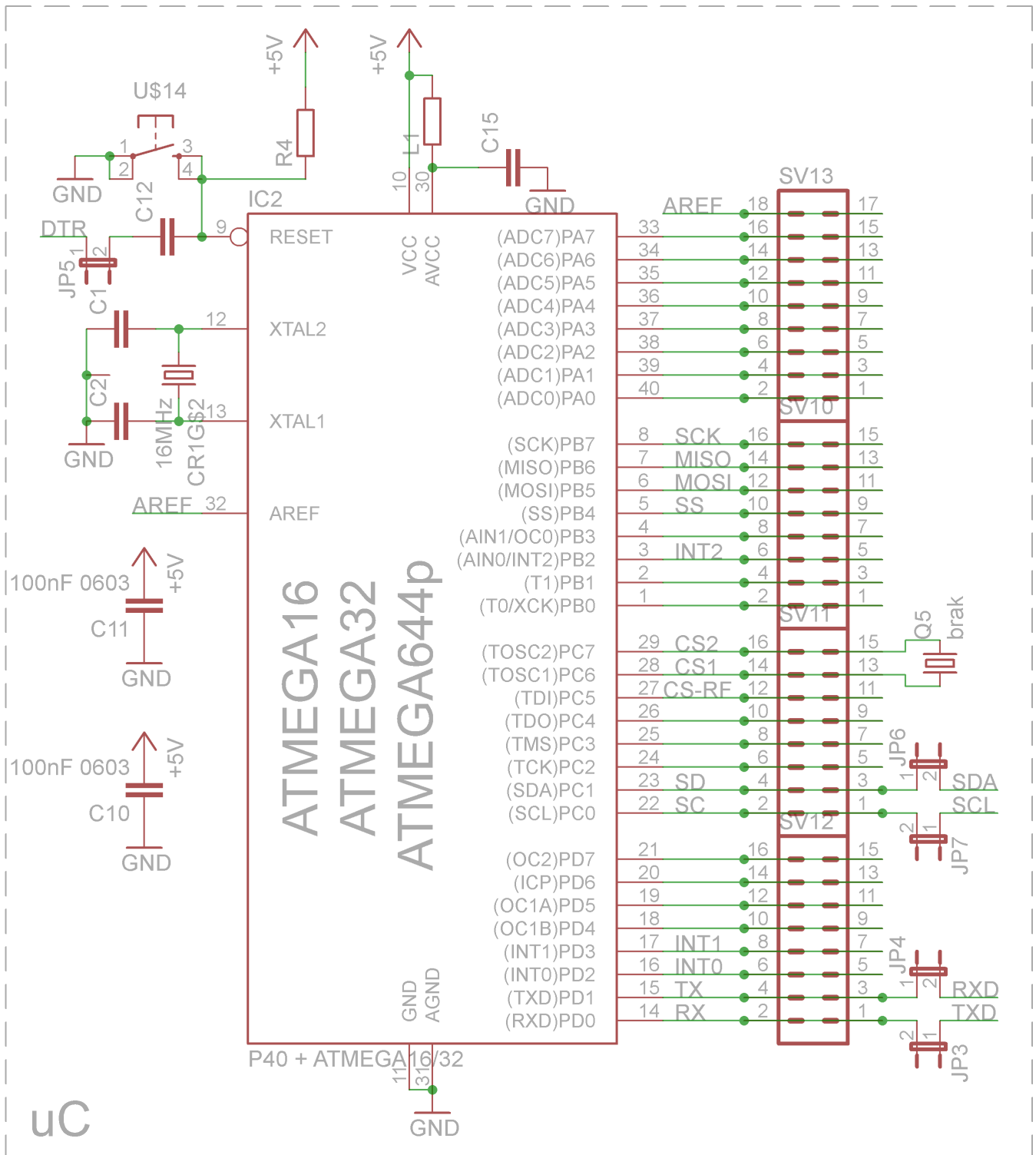

uC

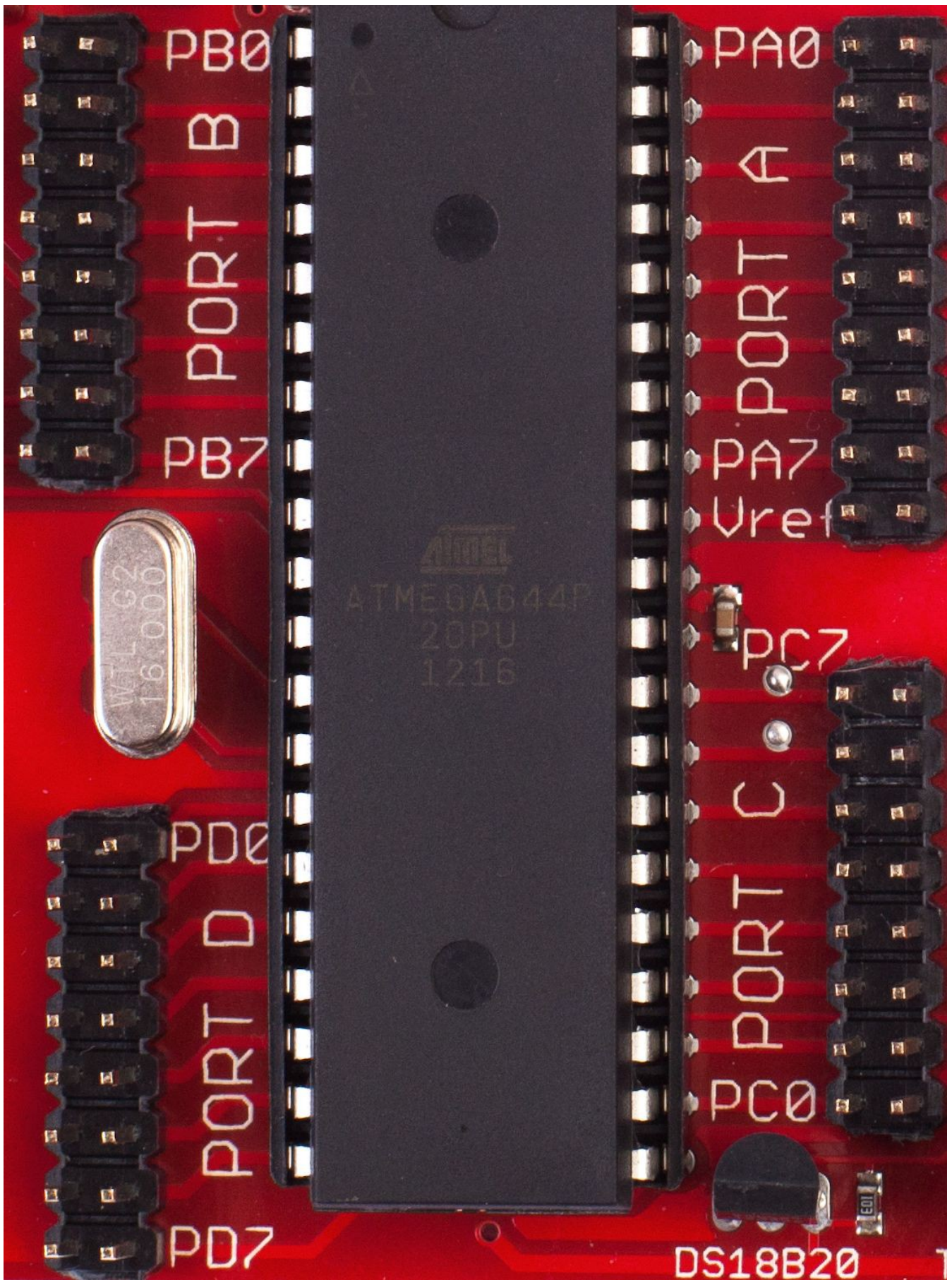

Programming via USB.

1. First, grab a program AND-Load from the website: www.and-tech.pl in Download section
2. Extract and run the program.
Select the hex file that you wish to program the processor.

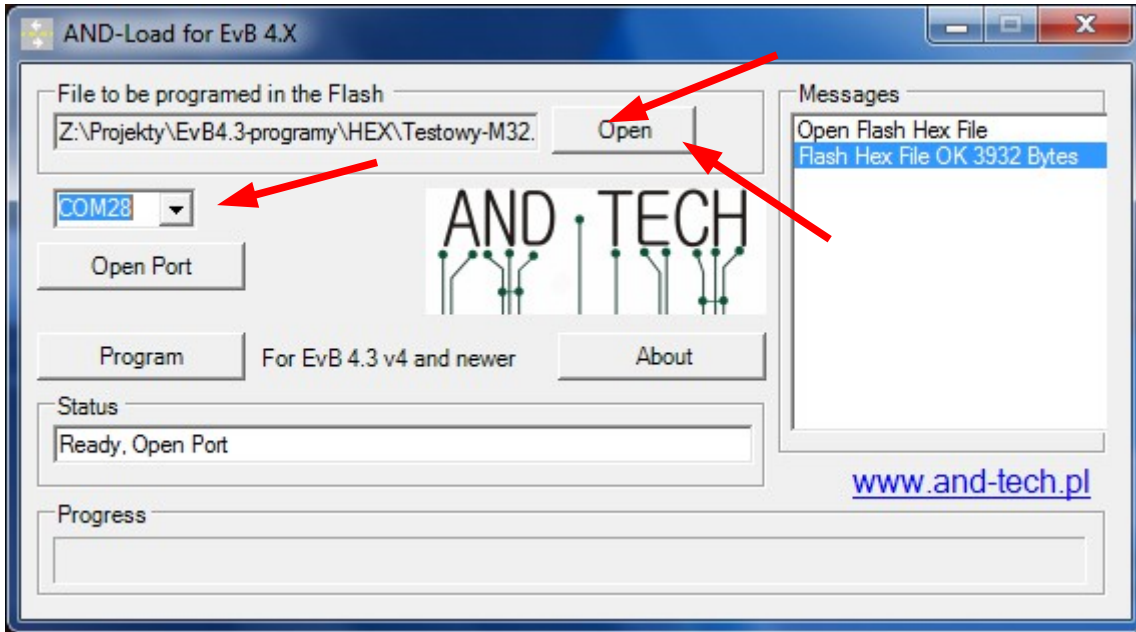

3. Select the COM port on which we have installed a set.

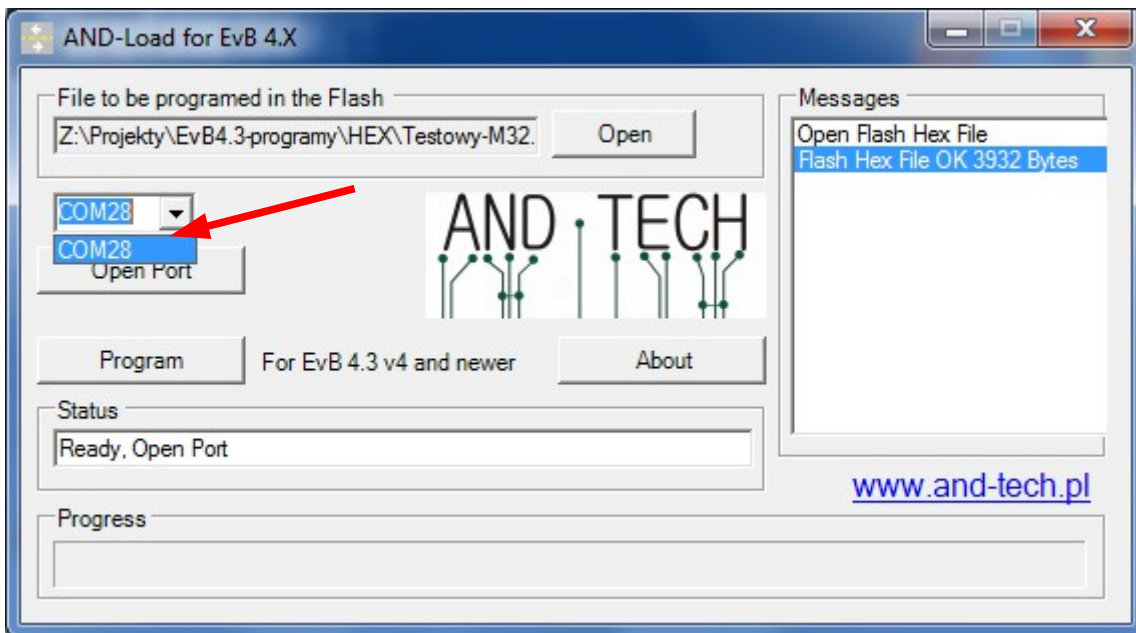

This information can be found on the COM port in the Device Manager.

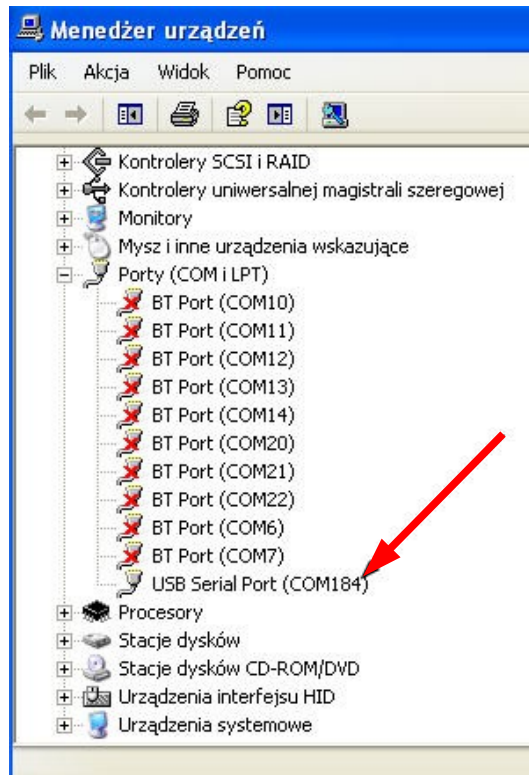

4. Then press the button, and click Open Port Program (version v3 and earlier press the RESET button on the EvB 5.1)

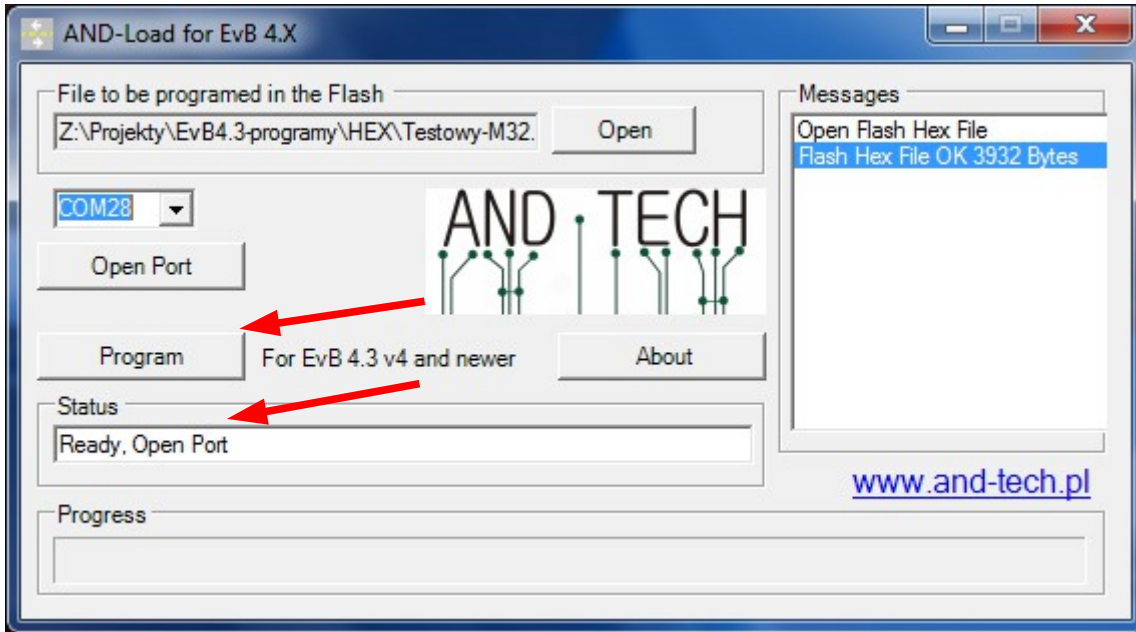

5. After pressing the button will program the processor to program the Flash memory.

When properly performed surgery will receive the message "Flash Prog Done!"

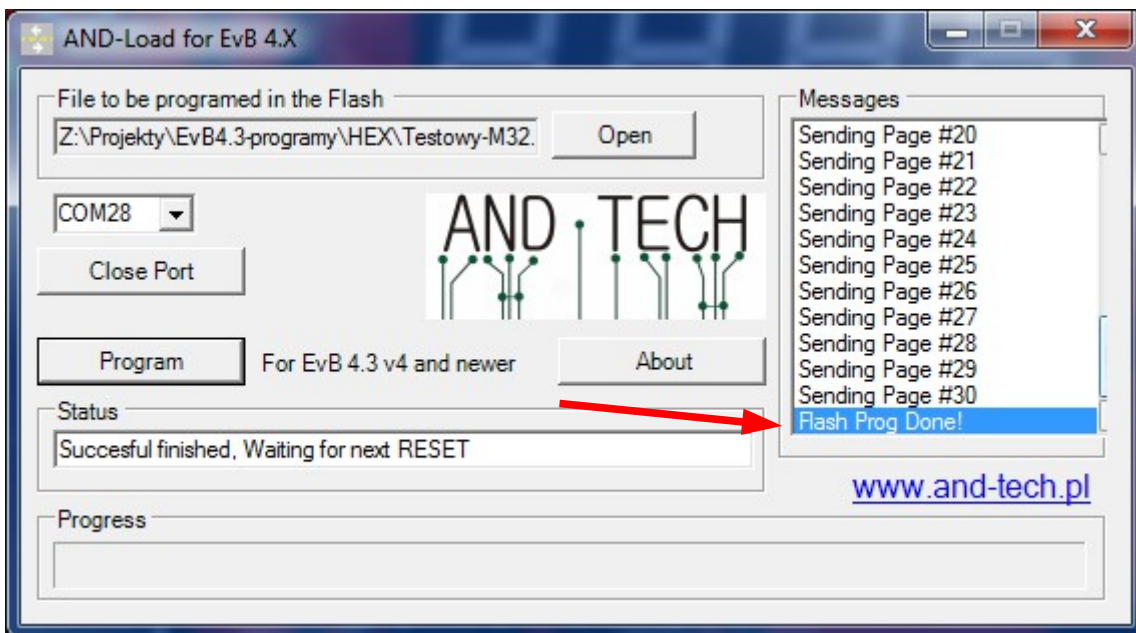

Before disconnecting the EVB board quit AND-Load.

Programming the AVR microprocessor with the EVB kit 4.3.

1. Connection of the microprocessor into the connector programmer.

The first step is to combine the microprocessor output with timer, as described below.

EvB	Microprocesor port ISP
TS	MISO
SR	SCK
CD	MOSI
RI	RESET

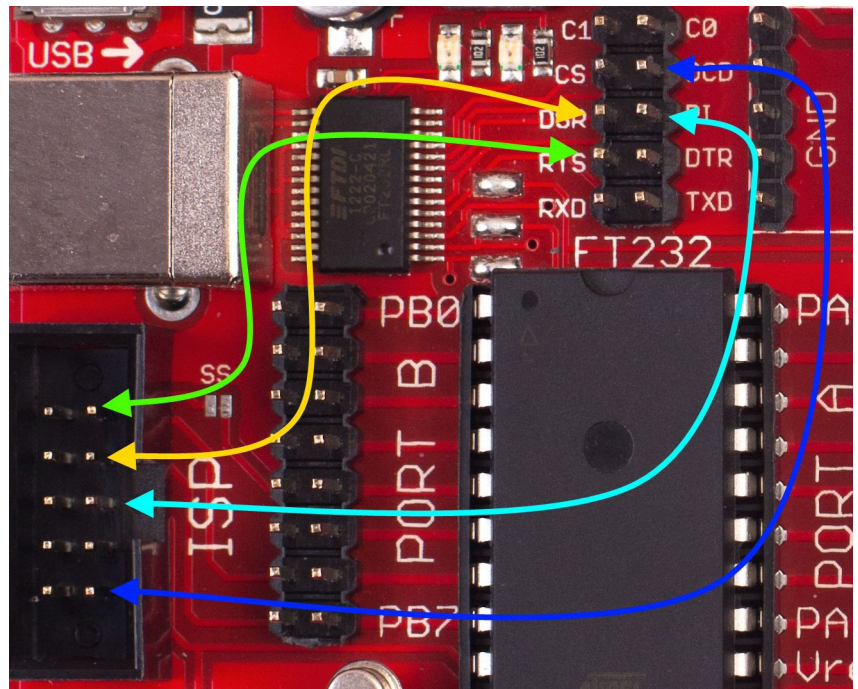

2. Connect the EvB 5.1 board to the computer (if the first connection of the system will ask for drivers).
3. Download the software from a specially prepared AVRDUDE files from the website: www.and-tech.pl/files/EvB-ISP.zip
4. Unpack the file and run the program avrdude-GUI.exe (requires. NET is at least version 2.0).
5. As a programmer choose FT232R Synchronous BitBang (EVB)
6. Select a processor that you want to set, in our case it is ATmega16

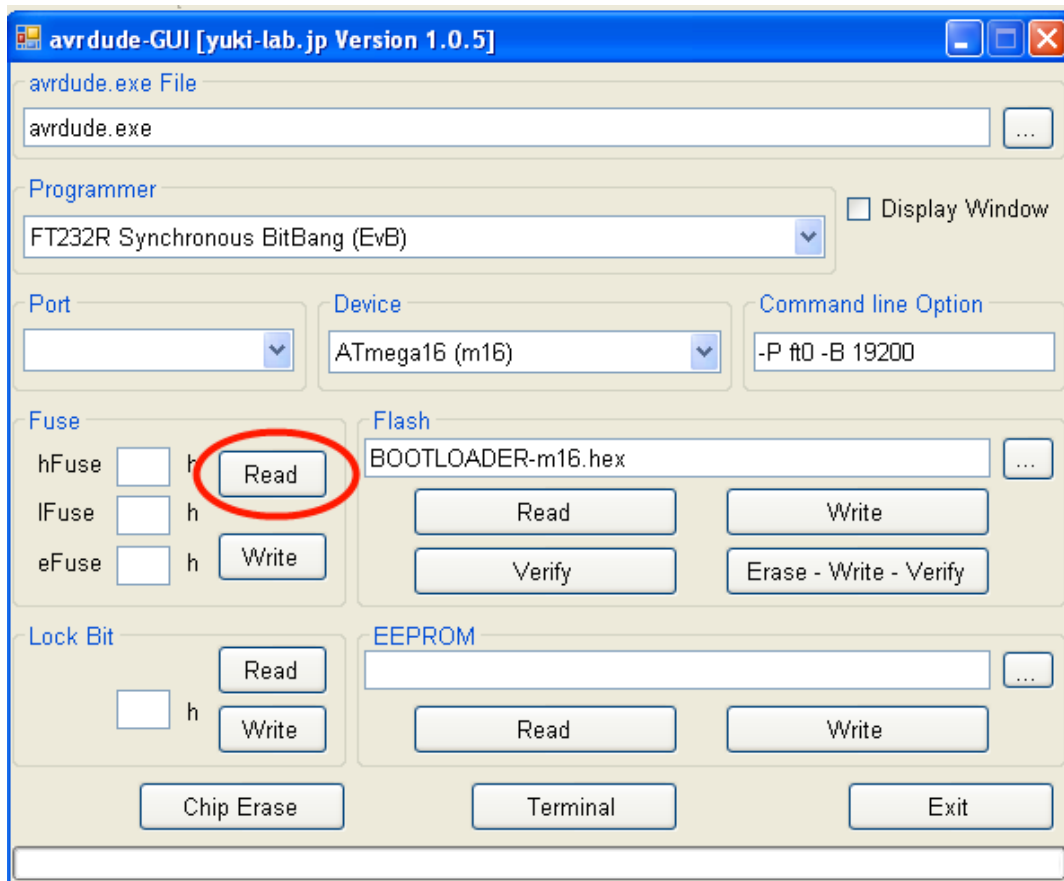

- In the "Command line Option" type-P 19200-B ft0
 Test your network connection through the Read button in the section Fuse
 If the windows hFuse, lFuse numbers appear it means that the programmer is working properly and we can program the processor in our file, if the screen appears as shown below, this means that the board is not properly installed on the system or poorly chosen settings.

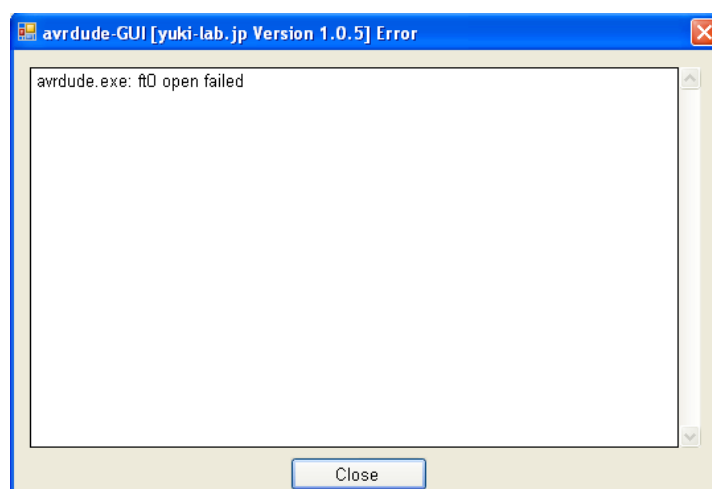

8. Select the file you want to upload to the processor and hit the button Erase-Write-Verify. After a few seconds, we should have a programmed microprocessor.

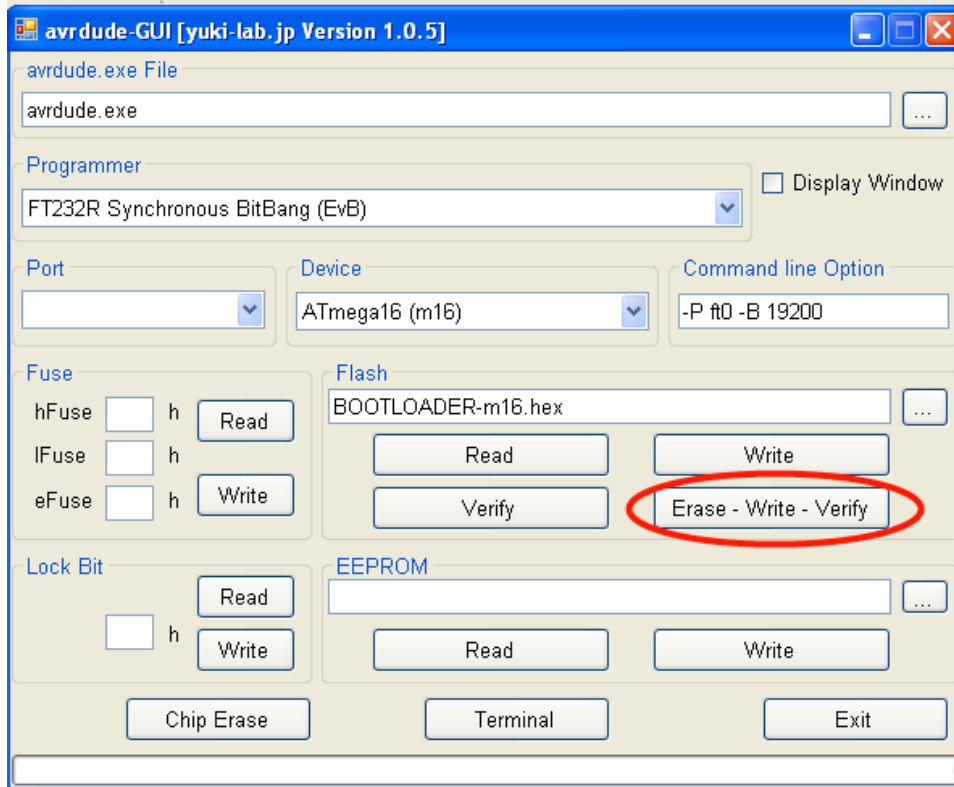

The above description of the microprocessor programming can also be used for the processor is not planted in the base set of EVB, but it is in this case, remember to connect the additional power and weight to a programmable processor (the best use of pin +5 V and GND from the board EVB).

Combining sets of EvB 5.1 BASCOM Environment

Download the latest version of AND-Load v3.2 with CL from <http://and-tech.pl/EvB4.3/AND-Load.zip>

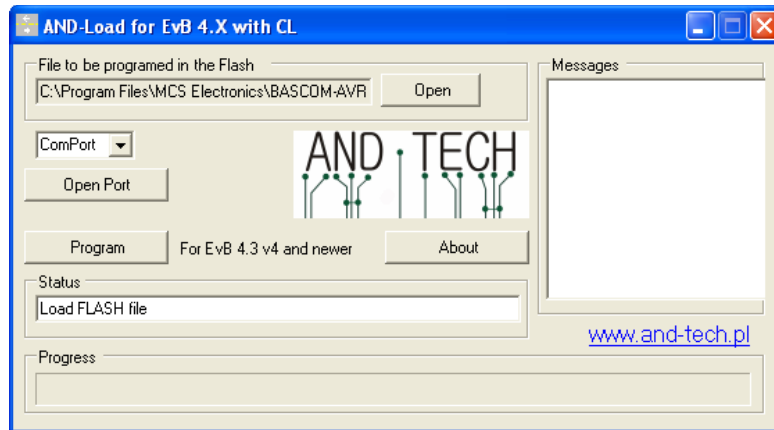

In the package, open the tab BASCOM Options → Programmer, select External programmer

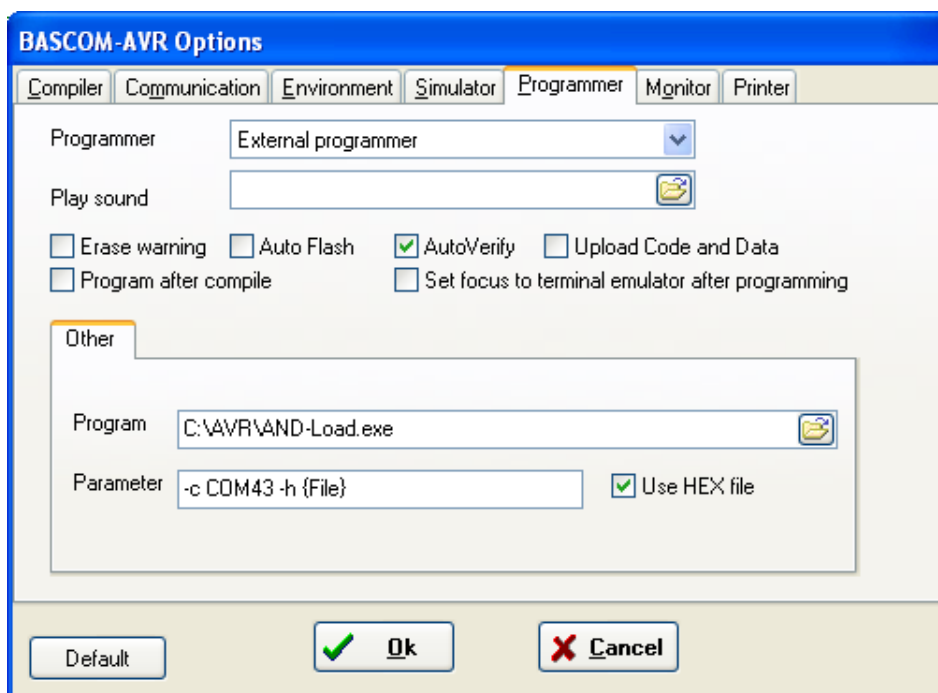

Then select the line The path to the AND-Load

In the Parameter type:
-c COMXX -h {File}

where COMXX is the COM port number on which the plate is installed
Be sure to check Use HEX file

Combining sets of EvB 5.1 WinAVR Environment

Download the latest version of AND-Load v3.2 with CL from
<http://and-tech.pl/EvB4.3/AND-Load.zip>

Run WinAVR

In meny Tools → Options → zakładka Tools select Scheme (None – Global Tools)

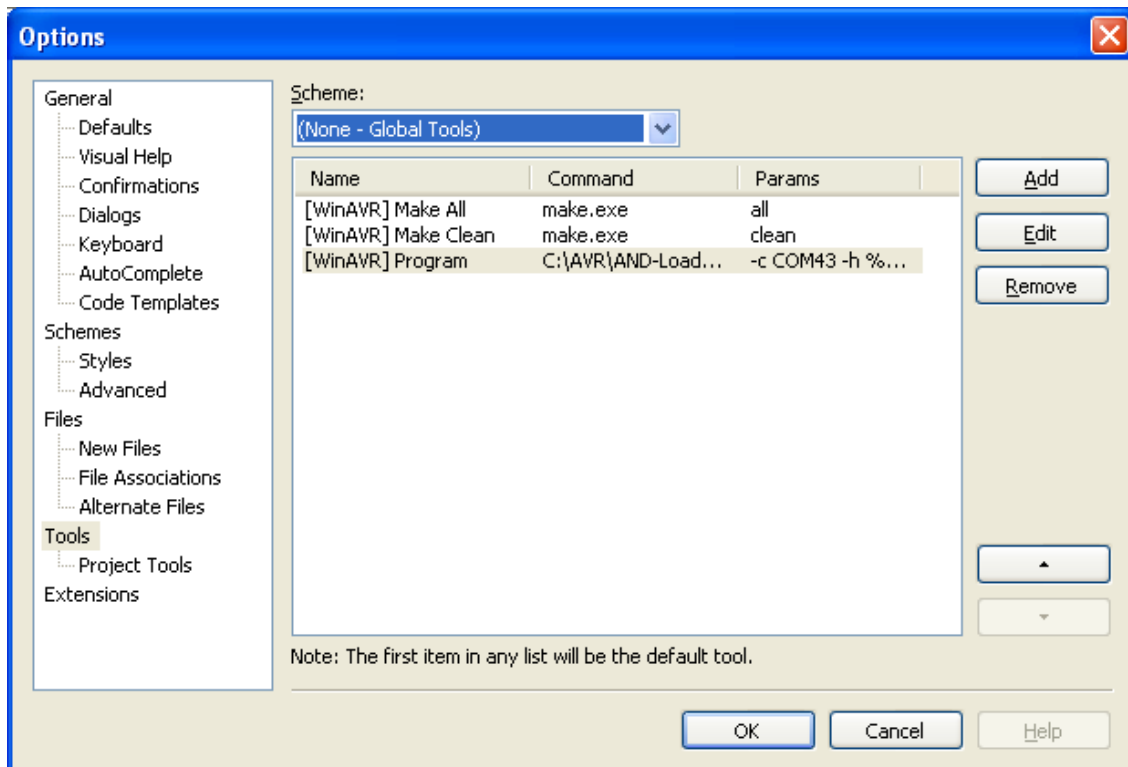

Modifying entry [WinAVR] Program as follows

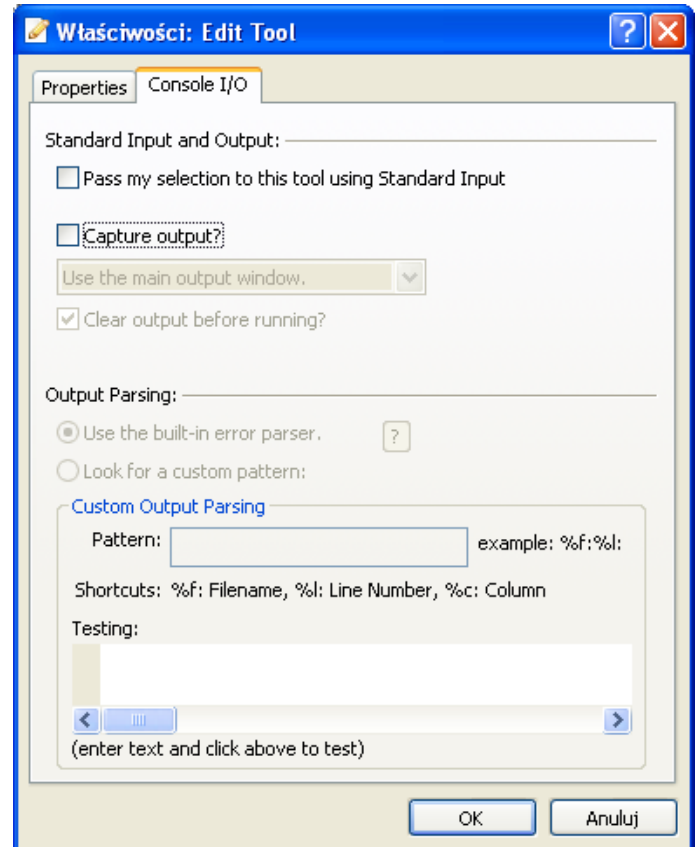
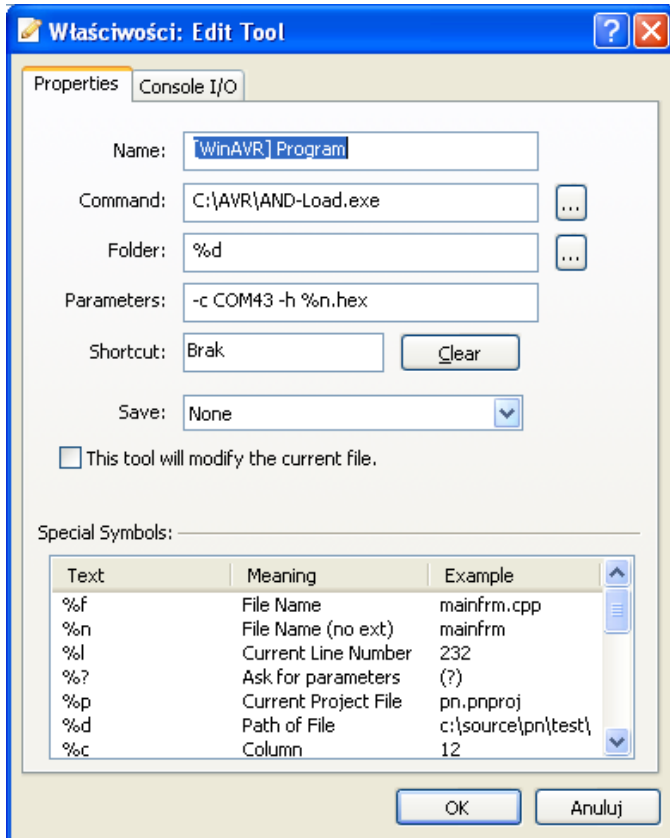

Then in the Command line, select the path to the AND-Load

In the Parameters COM43 is the COM port number on which the plate is installed

On the Console I / O uncheck „Capture output?”

Then, after compiling the program to upload the program simply select the command:
Tools → [WinAVR] Program

Environmental Protection

Marking by the symbol "crossed-out wheeled waste" tells about the ban on placing waste electrical and electronic equipment together with other wastes, used equipment should be collected separately. You must give used equipment to the point of collection to ensure its recycling and recovery, as the uncontrolled release into the environment of hazardous components in electrical and electronic equipment can become a source of danger to the health of humans and animals and can cause long-term adverse changes in the environment natural.

