

SILICON PLANAR DUAL SWITCHING DIODES

BAV70

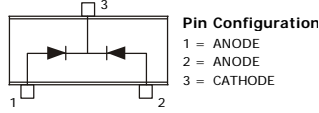
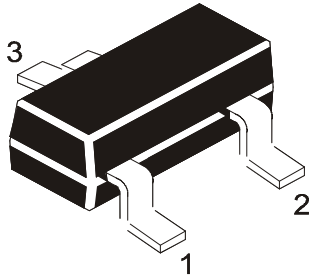

SOT-23 Formed SMD Package

For Lead Free Parts, Device Part # will be Prefixed with "T"

Marking

BAV70 = A4

High-Speed Switching Dual Diodes, Common Cathode

ABSOLUTE MAXIMUM RATINGS (Rating Per Diode)

DESCRIPTION	SYMBOL	VALUE	UNIT
Continuous Reverse Voltage	V_R	70	V
Repetitive Peak Reverse Voltage	V_{RRM}	75	V
Forward Current (DC)	I_F	215	mA
Repetitive Peak Forward Current	I_{FRM}	450	mA
Non Repetitive Peak Forward Current (per crystal)			
t=1 μ s	I_{FSM}	4.0	A
t=1 ms	I_{FSM}	1.0	A
t=1 s	I_{FSM}	0.5	A
Power Dissipation up to $T_a=25^\circ\text{C}$	P_D	250	mW
Storage Temperature Range	T_{stg}	- 55 to +150	$^\circ\text{C}$
Junction Temperature	T_j	150	$^\circ\text{C}$

THERMAL RESISTANCE

Junction to Ambient in free air	$R_{th(j-a)}$	500	K/W
---------------------------------	---------------	-----	-----

ELECTRICAL CHARACTERISTICS ($T_a=25^\circ\text{C}$ unless specified otherwise) per diode

DESCRIPTION	SYMBOL	TEST CONDITION	MIN	MAX	UNIT
Forward Voltage	V_F	$I_F = 1\text{mA}$ $I_F = 10\text{mA}$ $I_F = 50\text{mA}$ $I_F = 150\text{mA}$		0.715 0.855 1.0 1.25	V V V V
Reverse Current	I_R	$V_R=25\text{V}, T_J=150^\circ\text{C}$ $V_R=70\text{V}$ $V_R=70\text{V}, T_J=150^\circ\text{C}$		60 2.5 100	μA μA μA
Diode Capacitance	C_d	$V_R=0\text{V}, f=1\text{MHz}$		1.5	pF
Forward Recovery Voltage	V_{fr}	$I_F=10\text{mA}, t_r=20\text{ns}$		1.75	V
Reverse Recovery Time	t_{rr}	$I_F=10\text{mA},$ to $I_R=60\text{mA},$ $I_R=1.0\text{mA}, R_L=100\Omega$		4.0	ns
Reverse Charge When Switched Time	Q_S	$I_F=10\text{mA}$ to $V_R=5\text{V},$ $R_L=100\Omega$		45	pC

SOT-23 Formed SMD Package

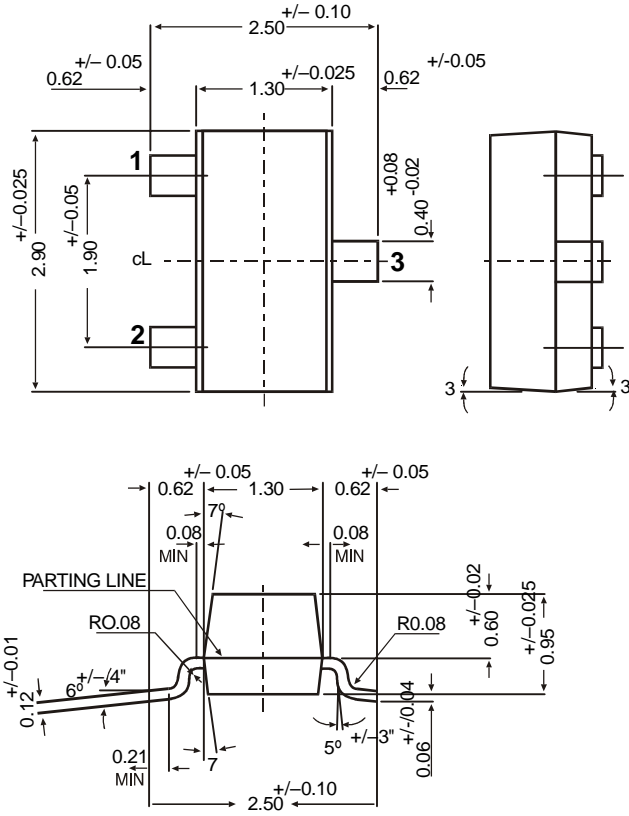

SOT-23 Package Reel Information
Reel specifications for Packing (13"/7" reels)

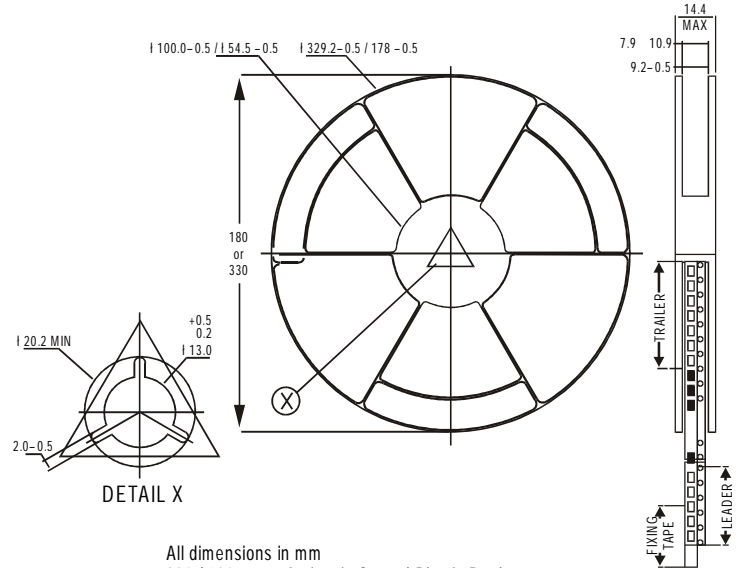

- NOTES:
- | | | |
|----------------|--------------|--------------|
| | 8mm Tape | 8mm Tape |
| | Size of Reel | Size of Reel |
| | 330 mm (13") | 180 mm (7") |
| No. of Devices | 10,000 Pcs | 3,000 Pcs |
- The bandolier of 330 mm reel contains at least 10,000 devices.
 - The bandolier of 180 mm reel contains at least 3,000 devices.
 - No more than 0.5% missing devices / reel. 50 empty compartments for 330 mm reel. 15 empty compartments for 180 mm reel.
 - Three consecutive empty places might be found provided this gap is followed by 6 consecutive devices.
 - The carrier tape (leader) starts with at least 75 empty positions (equivalent to 330 mm). In order to fix the carrier tape a self adhesive tape of 20 to 50 mm is applied. At the end of the bandolier at least 40 empty positions (equivalent to 160 mm) are there.

Tape Specification for SOT-23 Surface Mount Device

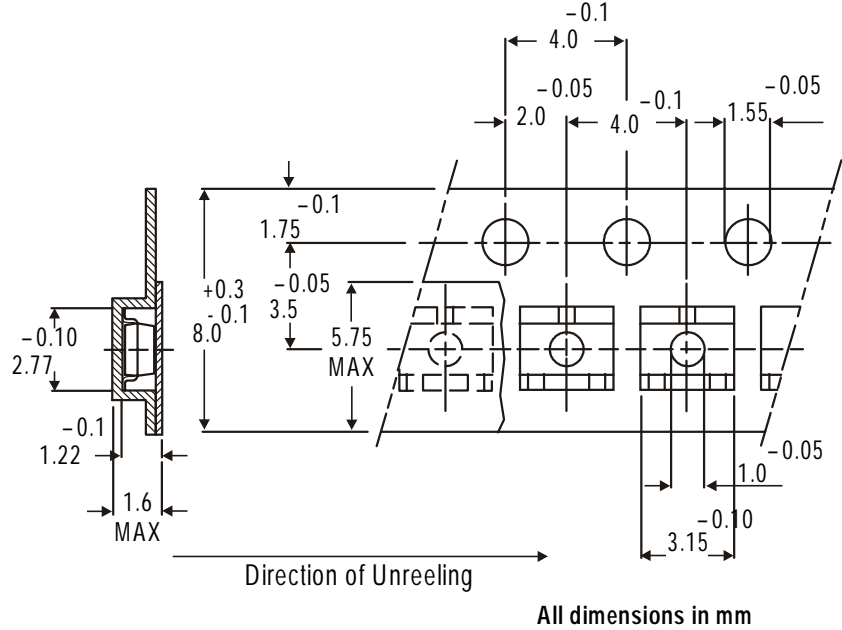

Packing Detail

PACKAGE	STANDARD PACK		INNER CARTON BOX		OUTER CARTON BOX		
	Details	Net Weight/Qty	Size	Qty	Size	Qty	Gr Wt
SOT-23 T&R	3K/reel	136 gm/3K pcs	3" x 7.5" x 7.5"	12.0K	17" x 15" x 13.5"	192.0K	12 kgs
			9" x 9" x 9"	51.0K	19" x 19" x 19"	408.0K	28 kgs
	10K/reel	415 gm/10K pcs	13" x 13" x 0.5"	10.0K	17" x 15" x 13.5"	300.0K	16 kgs

Customer Notes

Component Disposal Instructions

1. CDIL Semiconductor Devices are RoHS compliant, customers are requested to please dispose as per prevailing Environmental Legislation of their Country.
2. In Europe, please dispose as per EU Directive 2002/96/EC on Waste Electrical and Electronic Equipment (WEEE).

Disclaimer

The product information and the selection guides facilitate selection of the CDIL's Discrete Semiconductor Device(s) best suited for application in your product(s) as per your requirement. It is recommended that you completely review our Data Sheet(s) so as to confirm that the Device(s) meet functionality parameters for your application. The information furnished on the CDIL Web Site/CD are believed to be accurate and reliable. CDIL however, does not assume responsibility for inaccuracies or incomplete information. Furthermore, CDIL does not assume liability whatsoever, arising out of the application or use of any CDIL product; neither does it convey any license under its patent rights nor rights of others. These products are not designed for use in life saving/support appliances or systems. CDIL customers selling these products (either as individual Discrete Semiconductor Devices or incorporated in their end products), in any life saving/support appliances or systems or applications do so at their own risk and CDIL will not be responsible for any damages resulting from such sale(s).

CDIL strives for continuous improvement and reserves the right to change the specifications of its products without prior notice.



CDIL is a registered Trademark of

Continental Device India Limited

C-120 Naraina Industrial Area, New Delhi 110 028, India.

Telephone + 91-11-2579 6150, 4141 1112 Fax + 91-11-2579 5290, 4141 1119

email@cdil.com www.cdilsemi.com