

CERTIFICATION
OF THE QUALITY
SYSTEM OF THE
COMPANIES



UNI EN 29001
ISO 9001

Member of



The reproduction and/or divulgation of this drawing or its included informations is strictly prohibited unless authorized by the owning company DUCATI S.p.A. E' vietata la riproduzione e/o la divulgazione di questo disegno unitamente alle informazioni in esso contenute senza l'autorizzazione della DUCATI S.p.A.

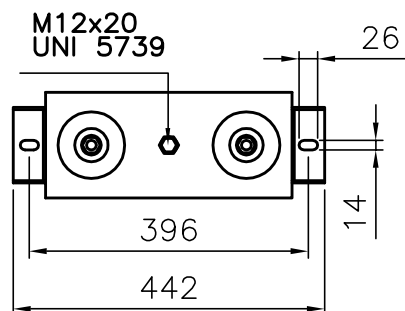
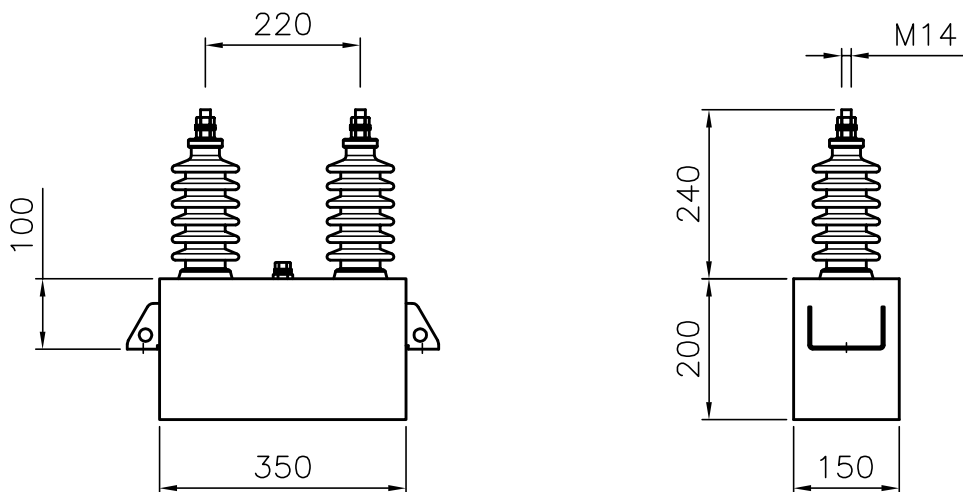

Qn= 67kvar Un= 3640V Fn= 50Hz
Cn= 16.1uF -5+10% In= 18.4A

INSULATION LEVEL / LIVELLO DI ISOLAMENTO: 28/75 kV
DISCHARGE DEVICE / RESISTENZE DI SCARICA: 75V/10 min.
DIELECTRIC / DIELETTRICO : ALL-FILM
BUSHING CREEPAGE / LINEA DI FUGA : 300mm
TEMPERATURE CLASS / CLASSE DI TEMPERATURA : -25/45
INTERNAL FUSES / FUSIBILI INTERNI : NO

Ed.	Descrizione/Description						Data/Date	Firma/Sign.
MODIFICHE/REVISIONS								
DUCATI energia s.p.a.		TOLL. QUOTE LIBERE (TOLERANCE RATE) UNI-ISO 2768-m	TOLL. QUOTE LIBERE ANG. (ANG. TOLERANCE RATE)	SCALA/SCALE 1:10	DATA/DATE 03.02.11	FIRMA/DRAWN S. Fornacciari	VISTO/CHECKED	
		OGGETTO/PART NAME POWER CAPACITOR CONDENSATORE DI RIFASAMENTO						CODICE/PART NR. 215594800
EDIZ./EDIT.								