

# PISPHV

For High Voltages up to 400V DC

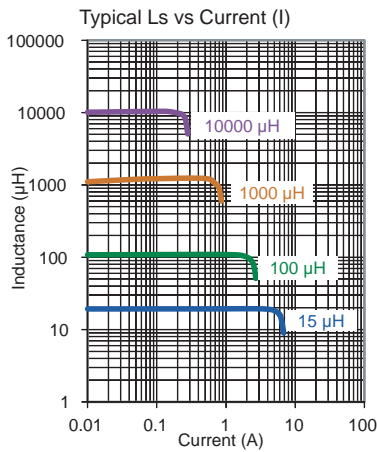
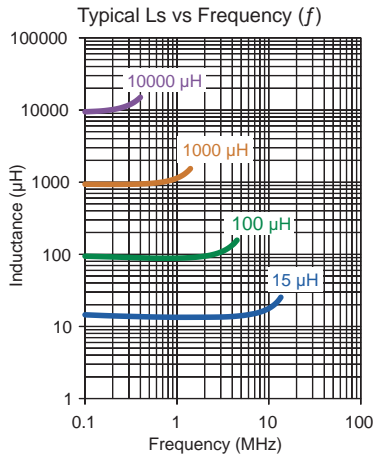
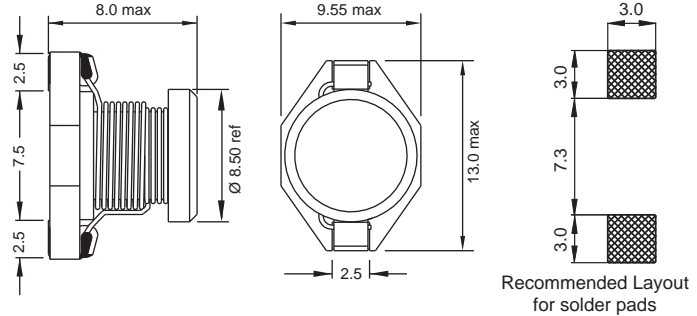

Part No	Inductance L (µH)	f <sub>l</sub> (MHz)	Tol ± (%)	SRF min (MHz)	DCR max (Ω)	Rated DC Current (A)	
						I <sub>sat</sub> typ	I <sub>ΔT = 40°C</sub> max
PISPHV-150M-04	15	0.1	20	13.5	0.035	4.20	3.15
PISPHV-220M-04	22	0.1	20	10.5	0.050	3.55	2.80
PISPHV-330M-04	33	0.1	20	8.5	0.073	2.90	2.35
PISPHV-470M-04	47	0.1	20	6.5	0.110	2.50	1.60
PISPHV-680M-04	68	0.1	20	6.0	0.140	2.00	1.45
PISPHV-101M-04	100	0.1	20	4.5	0.220	1.65	1.30
PISPHV-151M-04	150	0.1	20	4.0	0.325	1.40	1.00
PISPHV-221M-04	220	0.1	20	3.5	0.465	1.12	0.94
PISPHV-331M-04	330	0.1	20	2.5	0.670	0.95	0.80
PISPHV-471M-04	470	0.1	20	2.0	0.995	0.80	0.65
PISPHV-681M-04	680	0.1	20	1.7	1.484	0.70	0.55
PISPHV-102M-04	1000	0.1	20	1.5	2.185	0.60	0.45
PISPHV-222M-04	2200	0.1	20	1.0	5.000	0.35	0.30
PISPHV-103M-04	10000	0.1	20	0.4	23.30	0.17	0.12

**Core Material** : Ferrite  
**Base Material** : Plastic

Revision date : 25 Jul 2018

**SPQ** : Taped / Reel 250 [-04]

**Remarks :**

I<sub>sat</sub> & I<sub>ΔT</sub> - see description in Inductors Technical Data.  
Terminal clip with lead-free tinned surface for SMT-Reflow soldering.

SMD Power Inductors