

# JBC

[www.jbctools.com](http://www.jbctools.com)

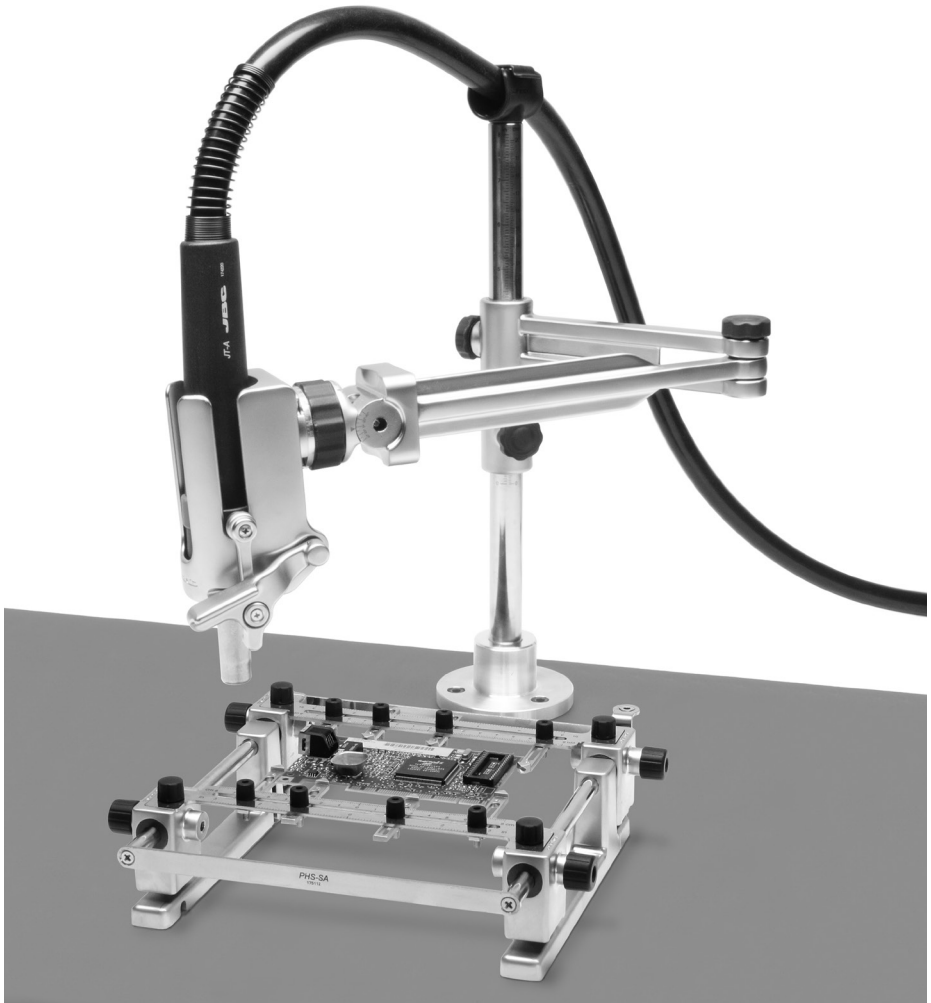

## Rework Adjustable Arm

Ref. RWT-B

# Packing List

The following items should be included:

**Tool Arm** ..... 1 unit



**Flange** ..... 1 unit  
Ref. 0017524



**Allen screw** ..... 1 unit  
Ref. 0017057



**Flange Screw** ..... 3 u  
Ref. 0017548



**Flange Nut** ..... 3 u  
Ref. 0892422



**Flange Washer** .. 3 u  
Ref. 0919480



**Allen key** ..... 1 unit  
Ref. 0013609



**Adapters** ..... 1 unit  
Ref. 0017058 (for JT-TA Heater)  
0017059 (for TE-TB Precision Heater)



**Manual** ..... 1 unit  
Ref. 0020500

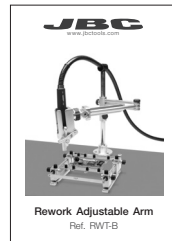

## Features

Ideal for working with JBC's Hot Air stations and Preheaters.

Ball Joint

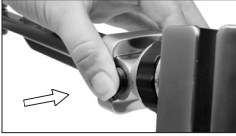

Adjust the tool head holder position according to your work needs

Hose Clamp



Vertical axis with ruler

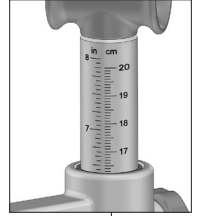

Turn the lever to lower the tool

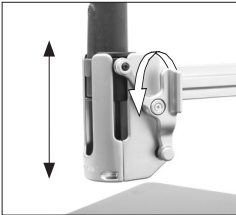

When you have finished raise the tool to free up the workspace.

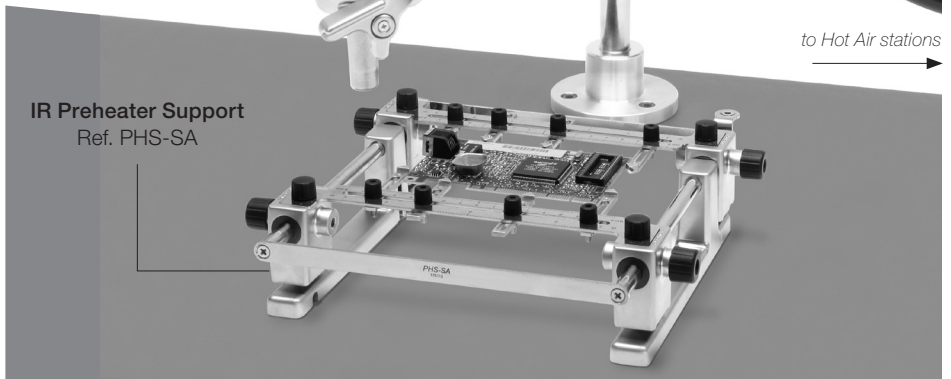

IR Preheater Support  
Ref. PHS-SA

# Assembly

## 1. Fixing the Flange

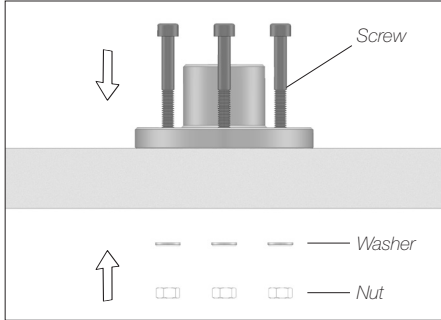

Fix the flange on your work table with the supplied screws, nuts and washers.

## 2. Setting up the Tool Arm

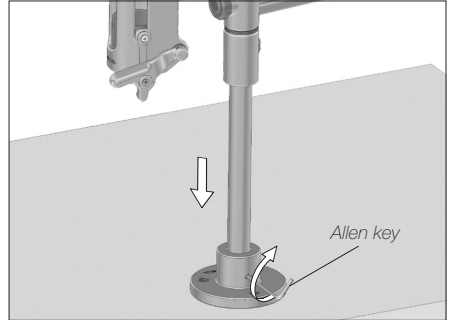

Fit the tool arm onto the flange and tighten the allen screw.

## 3. Inserting the Adapter (JT/TE)

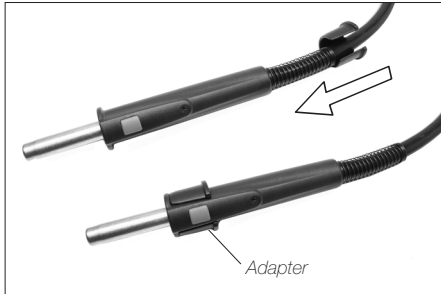

Slide the adapter along the hose to the end of the handle.

## 4. Mounting the Tool



Insert the tool as far as possible.

## 5. Place the hose in the clamp



## Height adjustment

- The RWT-B Arm allows adjustment for different heights according to your work needs through the vertical axis rule.
- Slide the tool holder to the appropriate height and secure by tightening the lower knob to guarantee stability. Make sure the upper knob is loosened before sliding the tool holder.

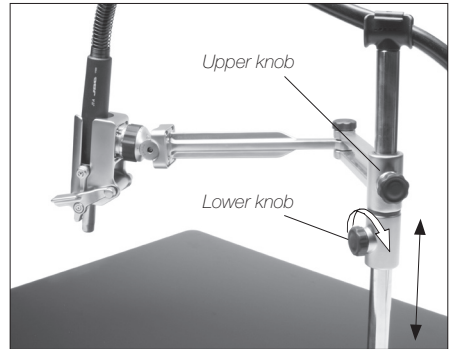

## Work position adjustment

The RWT-B arm allows adjustment for different positions according to your work needs. The articulated arm covers all work areas.

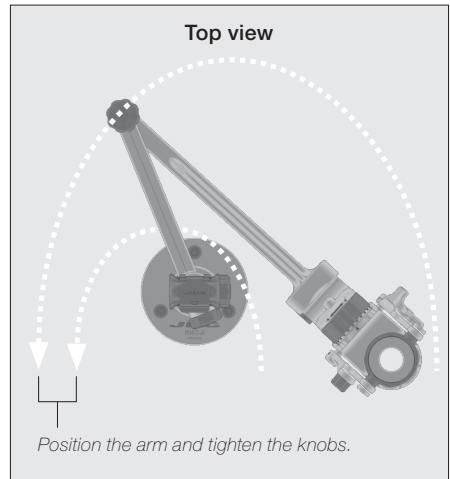

## Ball joint adjustment

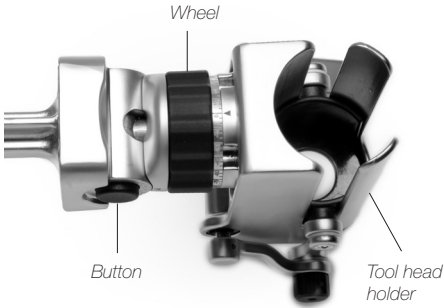

The ball joint for Rework Arm allows you to **adjust the tool head holder position** to suit your work needs.

Press the button or loosen the wheel to move the ball joint.

Both axes have a ruler to carry out the task with higher precision .

## Tilting movement:



By holding down the button you can rotate the ball joint up or down.



The movement allows a rotation of  $-40^{\circ}$  to  $+40^{\circ}$ .

## Rotation movement:

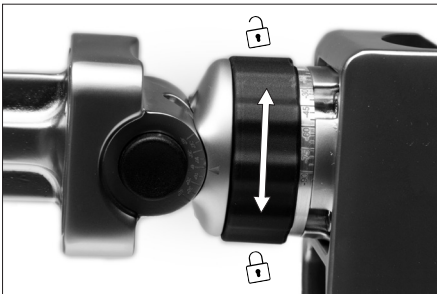

You can lock or unlock the lateral rotation mechanism by turning the fixing wheel a quarter.

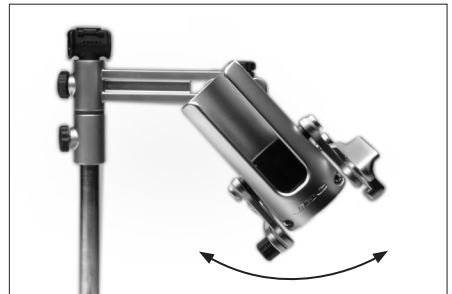

The movement allows a rotation of  $-90^{\circ}$  a  $+90^{\circ}$ .

## Maintenance

- Check periodically that the RWT-B is clean, especially the sliding parts and the shaft.
- Use a damp cloth when cleaning. Alcohol can only be used to clean the metal parts.
- Replace any defective or damaged parts. Use original JBC spare parts only.
- Repairs should only be performed by a JBC authorized technical service.

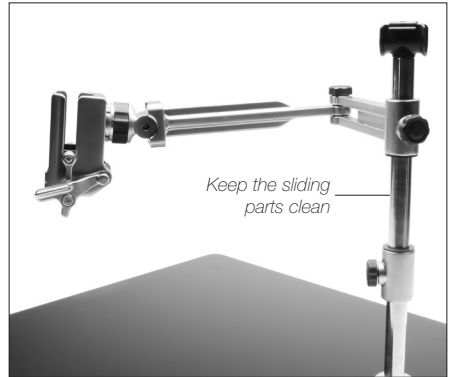

## Safety



**It is imperative to follow safety guidelines to prevent electric shock, injury, fire or explosions.**

- Do not use the equipment for any purpose other than PCB rework. Incorrect use may cause fire.
- The temperature of accessible surfaces may remain high after the unit is turned off. Handle with care.
- Be careful with the fumes produced when soldering.
- Keep your workplace clean and tidy. Wear appropriate protection glasses and gloves when working to avoid personal harm.
- Utmost care must be taken with liquid tin waste which can cause burns.
- This appliance can be used by children over the age of eight as well as persons with reduced physical, sensory or mental capabilities or lacking experience provided that they have been given adequate supervision or instruction concerning use of the appliance and understand the hazards involved. Children must not play with the appliance.
- Maintenance must not be carried out by children unless supervised.

Exploded View

**RWT-B**

REWORK ADJUSTABLE ARM

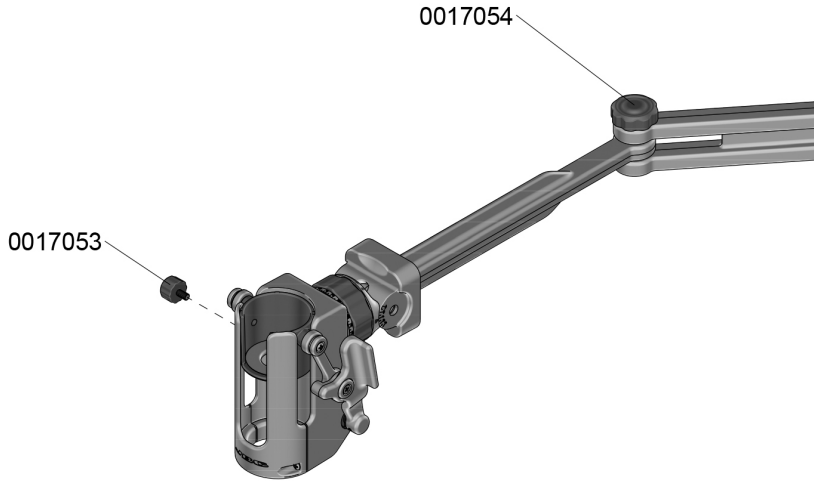



## SPARE PARTS

### RWT:

-TOOL HEIGH ADJ. KNOB:	0017053
-ROTATION ADJ. KNOB:	0017054
-HEIGHT ADJ. KNOB:	0017055
-HOSE CLAMP:	0017056
-SCREW:	0017057
-JT TOOL ADAPTER:	0017058
-TE TOOL ADAPTER:	0017059

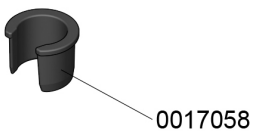
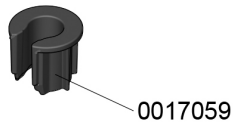
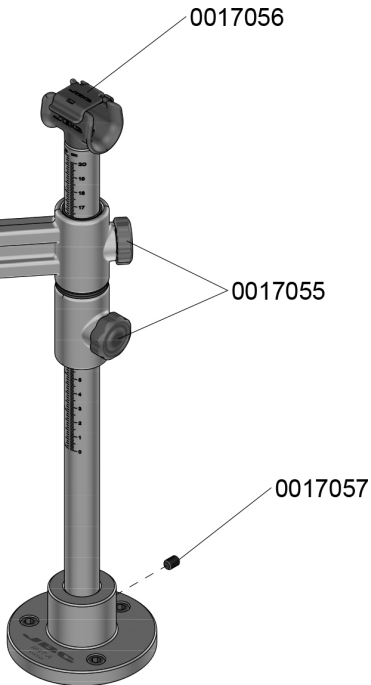





# Specifications

- Total weight: 4 kg (8.81 lb)
- Height: 386,5 mm (15.21 in)
- Arm length: 444,5 mm (17.50 in)
- ESD safe connector

Complies with CE standards.  
ESD protected housing.

# JBC

## Warranty

JBC's 2 year warranty covers this equipment against all manufacturing defects, including the replacement of defective parts and labour.

Warranty does not cover product wear or misuse.

In order for the warranty to be valid, equipment must be returned, postage paid, to the dealer where it was purchased.

**Register your warranty within 30 days of purchase in [www.jbctools.com/productregistration](http://www.jbctools.com/productregistration)**



This product should not be thrown in the garbage.

In accordance with the European directive 2002/96/EC, electronic equipment at the end of their life must be collected and returned to an authorized recycling facility.



Manual in other languages available on our website

**[www.jbctools.com](http://www.jbctools.com)**