

PPD-130 PERISTALTIC PUMP DISPENSER

OPERATING MANUAL



15 Corporate Drive, Suite E - Wayne - NJ 07470
Tel: (973) 646-5044 E-mail: info@fisnar.com
www.fisnar.com

1.0 CAUTIONS AND WARNINGS

CAUTION:

- EYE PROTECTION REQUIRED

WARNINGS:

- Read the material safety data sheets to find out special precautions you must take while dispensing the specific material.
- Wear protective safety equipment as specified in the material safety data sheets.
- Check with the factory if you are not sure about dispensing materials other than cyanoacrylates
- Cyanoacrylate adhesives are severe eye irritants and skin bonders. Immediate bonding of eyes, skin or mouth may occur upon contact. These adhesives may also cause permanent eye damage.
- Avoid eye, mouth and skin contact. Use full cover safety glasses. Avoid breathing adhesive vapors. Provide adequate ventilation.
- If eye becomes bonded, quickly soak it in warm water. Do not use excessive force to free bonded areas.
- Before using flammable solvents, extinguish all open flames in the immediate work areas and observe proper precautionary measures for handling the material.
- Due to the electronic nature of this equipment and the potential for a spark or generation of heat, note that this equipment most **NOT** be used with any explosive material or in an explosive type environment.

2.0 INTRODUCTION

The PPD-130 Peristaltic Pump Dispenser provides “volumetric” dispensing of low- viscosity materials such as cyanoacrylates, oils and solvents without the need for compressed air.

The PPD-130 uses peristaltic pump technology to dispense material directly from its original packaging. There is no need to transfer the material from its original container. By doing so, the risk of material contamination and operator contact is reduced.

PPD-130 is ideal for dispensing cyanoacrylates and solvents as it dispenses without the use of compressed air.

The suck-back feature automatically reverses the pump after dispensing to prevent material from dripping between cycles.

Dispensed amounts may be controlled manually or with the built-in timer.

Maintenance and cleanup are simple because material never comes in contact with the dispensing mechanism. Reversing the pump allows the material tube to be emptied between work cycles.

SPECIFICATIONS:

POWER SOURCE	100-240VAC 50/60 HZ
TIME RANGE	0.01 TO 99.99 SECONDS (CW and CCW)
ROTOR SPEED	VARIABLE SPEED, 120 RPM MAXIMUM
DIMENSIONS	182.4mm (W) X 171mm (D) X 81.2mm (H)
WEIGHT	3 Kg

FEATURES:

- ⇒ Easy installation and operation
- ⇒ Ultra-minute shot sizes possible
- ⇒ Manual or Timer controlled shot size
- ⇒ Dispense material directly from bottle or can - no need to load barrels
- ⇒ Input / Output connectors for integration with XYZ systems or other equipment
- ⇒ Suck-Back feature prevents material from dripping between cycles
- ⇒ Patented rotor design for longer tube life
- ⇒ Variable pump speed permits adjustment of the flow rate
- ⇒ Reversible pump allows material lines to be emptied when work is complete
- ⇒ Simple maintenance and no “clean up”
- ⇒ Effectively dispenses materials such as Cyanoacrylates, UV Adhesives, Fluxes, Solvents, Oils, Paints, Activators

3.0 ACCESSORIES

PART NO.	QUANTITY	DESCRIPTION
562030-T	1	STANDARD PUMP HEAD
560989-D	1	NOZZLE HOLDER WITH SWITCH
561010-D	1	NOZZLE 1.7mm DIAMETER
561011-D	1	NOZZLE 2.1mm DIAMETER
561012-D	1	NOZZLE 2.6mm DIAMETER
561013-D	1	NOZZLE 3.5mm DIAMETER
560984P	1	1m (3.28 ft) HOSE 1.0 mm X 1.6 mm
560985P	1	1m (3.28 ft) HOSE 1.4 mm X 2.0 mm
560995P	1	1m (3.28 ft) HOSE 1.9 mm X 2.5 mm
560996A	1	1m (3.28 ft) HOSE 2.4 mm X 3.0 mm
562031-D	1	9-PIN CONNECTOR
562032-D	1	FOOT PEDAL (OPTIONAL – NOT INCLUDED)

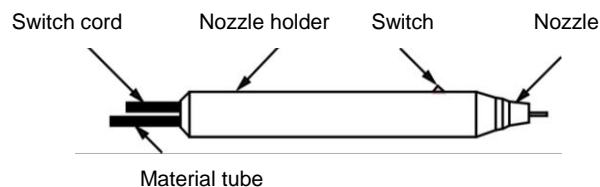

PUMP HEAD	AVAILABLE TUBING			SUITABLE NOZZLE TYPE	
	CLEAR TUBING PART #	BLACK TUBING PART #	I.D. X O.D.	PART#	DESCRIPTION
562030-T (STANDARD)	560984P	560984BA	1.0 mm X 1.6 mm	561010-D	NOZZLE 1.7 DIA
	560985P	560985BA	1.4 mm X 2.0 mm	561011-D	NOZZLE 2.1 DIA
	560995P	560995BA	1.9 mm X 2.5 mm	561012-D	NOZZLE 2.6 DIA
	560996A	560996BA	2.4 mm X 3.0 mm	561013-D	NOZZLE 3.5 DIA
562030-M (OPTIONAL)	560997P	560997BA	0.25mm X .75mm	-	-
562030-S (OPTIONAL)	560998A	560998BA	0.5 mm X 1.0 mm	561008-D	NOZZLE 0.9 DIA
	560999A	560999BA	0.6 mm X 1.1 mm	-	-
562030-G (OPTIONAL)	562033	-	0.5 mm X 2.5 mm	561012-D	NOZZLE 2.4 DIA
	562034	-	3.0 mm X 5.0 mm	-	-
	562035	-	8.0 mm X 10 mm	-	-

4.0 OPERATING PANEL CONTROLS

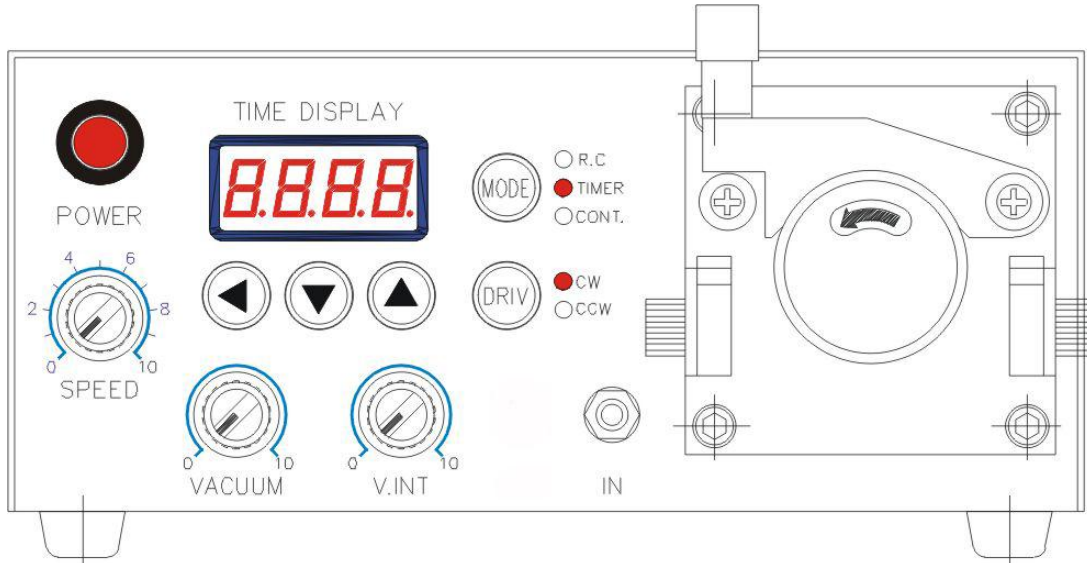

4.1 POWER

Pressing the POWER switch will turn the unit ON and OFF.

4.2 MODE

Pressing the MODE button will switch the unit in one of the following three modes:

RC – REMOTE CONTROL MODE:

When the unit is in RC mode, the rotor will rotate as long as the nozzle holder switch is depressed.

TIMER MODE:

When the unit is in TIMER mode, pressing the nozzle holder switch will make the rotor rotate for the time interval set on the timer (0.01 to 99.99 seconds).

CONTINUOUS RUN MODE:

When the unit is in CONTINUOUS RUN mode, the rotor will rotate continuously.

4.3 DRIV

Pressing the DRIV button will switch the direction the rotor rotates from CW (clockwise) to CCW (counterclockwise) and from CCW to CW.

4.4

Use  buttons for setting the dispensing time (0.01 to 99.99 seconds).

Press  to select the digit you want to change.

Press  to decrease or increase the value of the selected digit.

4.5 SPEED

The rotor SPEED can be varied from 0 to 120 rpm.

4.6 VACUUM

VACUUM knob allows you to adjust the time that the rotor will rotate in reverse direction after the dispensing operation.

4.7 V. INT

This allows you to adjust the time interval needed for the rotor to change direction from CW to CCW or from CCW to CW after the dispensing operation.

4.8 IN

Insert the switch cord plug into the IN receptacle.

4.9 FOOT SWITCH

You can use the foot switch connector on the backside of the unit to connect the PPD-130 to a robot, or to control the PPD-130 with a foot pedal (optional). To activate the unit through the foot switch connector, you must provide a dry closure between pin 1 (+5V) and pin 9 (0V).

Also, you can get END OF DISPENSE SIGNAL when the dispense cycle is complete. This output can be used to signal a robot or other external device that dispensing is finished.

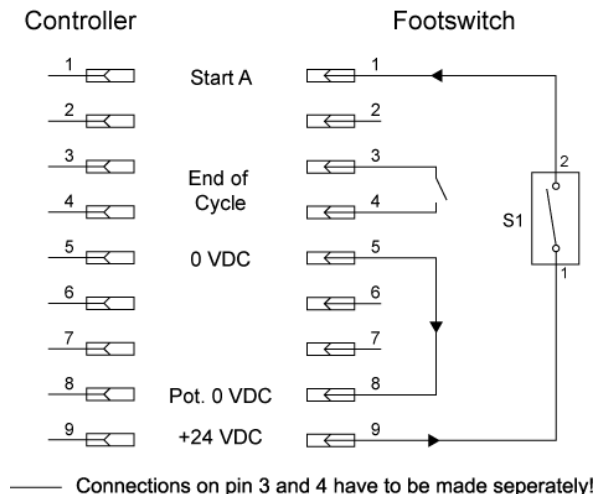

5.0 SET - UP AND OPERATION

5.1 Connect POWER CORD to unit.

5.2 Insert the material tube into the PUMP HEAD as follows:

- A. Pull the GUIDE LOCK to the left and open the TUBE GUIDE.
- B. Insert the tube into the right GROOVE, over the ROTOR HEAD and into the left GROOVE.

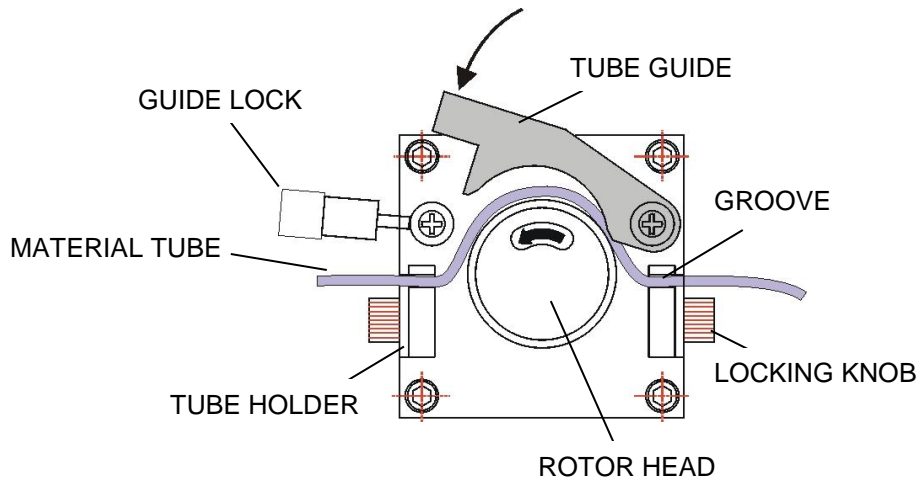

- C. Slowly close the TUBE GUIDE while turning the rotor. Secure the TUBE GUIDE by pulling the GUIDE LOCK in the upward direction. If you are inserting a thick tube and the rotor stops, start over. If the TUBE GUIDE is tightened without turning the rotor, the shape of the rotor will be impressed on the tube and the tube will not be inserted evenly. Always turn the rotor while closing the TUBE GUIDE.
- D. Lift the TUBE HOLDERS to support the tube at both ends. Secure the TUBE HOLDERS using the LOCKING KNOBS.

- E. Cut the end of the tube as shown to make insertion into nozzle easier.

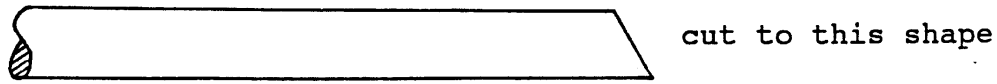

- F. Pass the tube through the nozzle holder, then through the nozzle. Pull out the exposed section of the tube with pliers or other tool. Insert the nozzle into the holder.

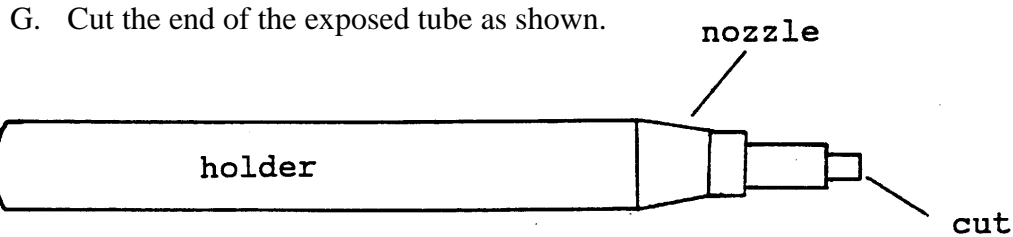

5.3 Insert MATERIAL TUBE into bottle.

MAINTENANCE POINTERS:

- ⇒ Lubricate the rollers of the ROTOR HEAD once or twice a week. Lubrication will help prolong tube life.
- ⇒ The MATERIAL TUBE should be replaced periodically. The lifespan of the tube will vary depending of the rotation speed, frequency of use, etc. The user should determine how often to replace the tube according to their needs.

5.4 Insert the switch cord plug into the IN receptacle.

5.5 Turn POWER switch ON.

5.6 Adjust TIMER to meet your needs and depress the nozzle holder switch to start operation.

5.7 After you finish dispensing, press the DRIV button to return liquid back to bottle.

PPD –130 WARRANTY

Manufacturer warrants this product to the Original purchaser for a period of one year from the date of purchase to be free from defects in material and workmanship, but not against damages caused by misuse, negligence, accident, faulty installation, abrasion, corrosion or by not operating in accordance with factory recommendations and instructions. Manufacturer will repair or replace (at factory's option) free of charge, any component of the equipment thus found to be defective, upon return of the component "PREPAID" to the factory during the warranty period of the equipment. This warranty is only valid if the defective PPD-130 Peristaltic Pump Dispenser is returned as a complete assembly without physical damage. The manufacturer's written liability, as stated herein, cannot be altered or enlarged except by a written statement signed by an officer of the company. A return authorization is required from FISNAR INC. prior to shipping a defective unit to the factory.

Manufacturer reserves the right to make engineering or product modifications without notice.

