

MV-0180LF OPERATING MANUAL



15 Corporate Drive, Suite E - Wayne - NJ 07470
Tel: (973) 646-5044 E-mail: info@fisnar.com
www.fisnar.com

© FISNAR INC. 2006

MV-0180 MINI VALVES

The line of MV-0180 series of Mini - Valves is designed for precision dispensing of all types of fluids in minute to moderate volumes. The valves' light weight and pencil-type grip makes the valves ideal for either hand-held or automatic systems applications.

OPERATING INSTRUCTIONS

1. Connect air supply to the AIR INLET of air cylinder (MV-003LF), see page 5.

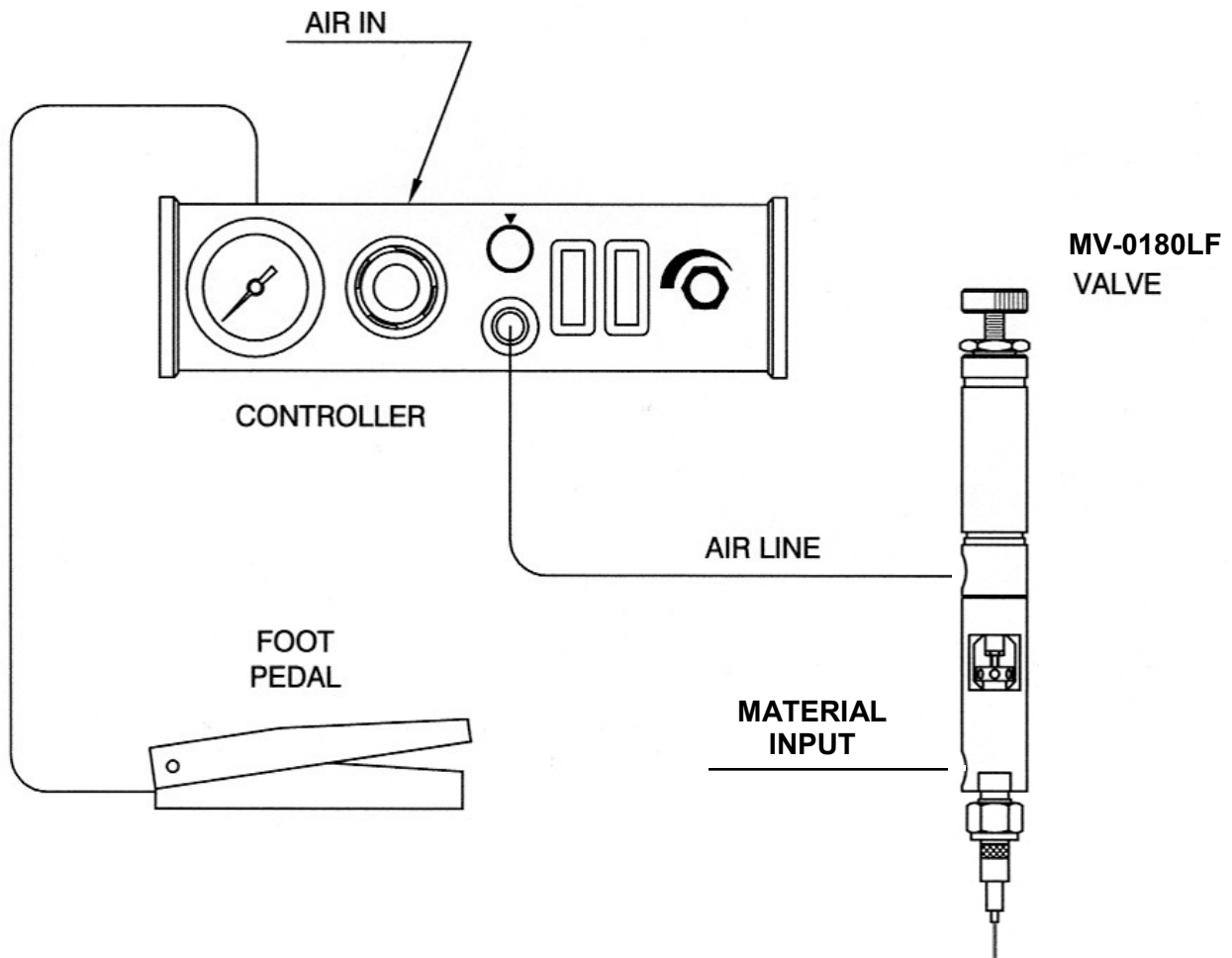

2. **IMPORTANT:** Before running fluid into valve, check tightness of the packing nut as follows:
 - 2.1 With air pressure to the controller set at 60 psi, cycle the valve to open and close.
 - 2.2 With the valve cycling, tighten packing nut MV-024LF with packing tool MV-025LF until plunger retracts slowly.
3. Reset air pressure to normal setting of 85 - 95 psi.
4. Connect material supply tubing to valve port using appropriate fitting.
5. With fluid supply on, open valve and by activating controller inspect flow. Raise or lower fluid pressure and / or change tip size to achieve desired flow. The valve is equipped with an adjustment screw MV-001LF, which limits the back stroke of the plunger MV-028LF for fine tuning the desired flow. Once adjustment has been made, turn locking nut MV-002LF to hold adjustment screw at desired level.
6. Repeat section # 2 prior to dispensing on a daily basis.

SERVICE NOTES

If valve fails to dispense fluid when activated:

1. Check air pressure setting of air inlet line (85 psi or greater).
2. Check fluid pressure source.
3. Check nozzle for cured or foreign material.
4. If plunger fails to move when valve is activated, disassemble, clean, replace MV-022LF and re-assemble.
5. To remove packing assembly MV-022LF from valve body MV-023LF, unscrew valve body from upper air cylinder MV-003LF . Remove packing nut MV-024LF from valve body. Remove nut MV-010LF, seat MV-012LF and needle holder MV-013LF from valve body. Take packing tool MV-025LF and insert into the fluid outlet end of the valve body and push old packing out.
6. To replace packing assembly MV-022LF into valve, first slide packing nut MV-024LF on to plunger MV-023LF . Remove packings from cartridge and drop one packing into the packing area of the valve body. With packing tool press first packing down into cavity until packing is full seated. Repeat for packings two, three and four. Insert plunger into valve body, screw valve body and air cylinder together. Screw packing nut into valve body.
7. Replace seat, nut needle holder, washers per print.
8. Repeat operating instructions.

NOTE:

If plunger is replaced, place a drop of “thread locking compound” on new plunger and thread plunger into cylinder to a protruding length of 2 3/8”.

BE CAREFUL NOT TO SCORE PLUNGER.

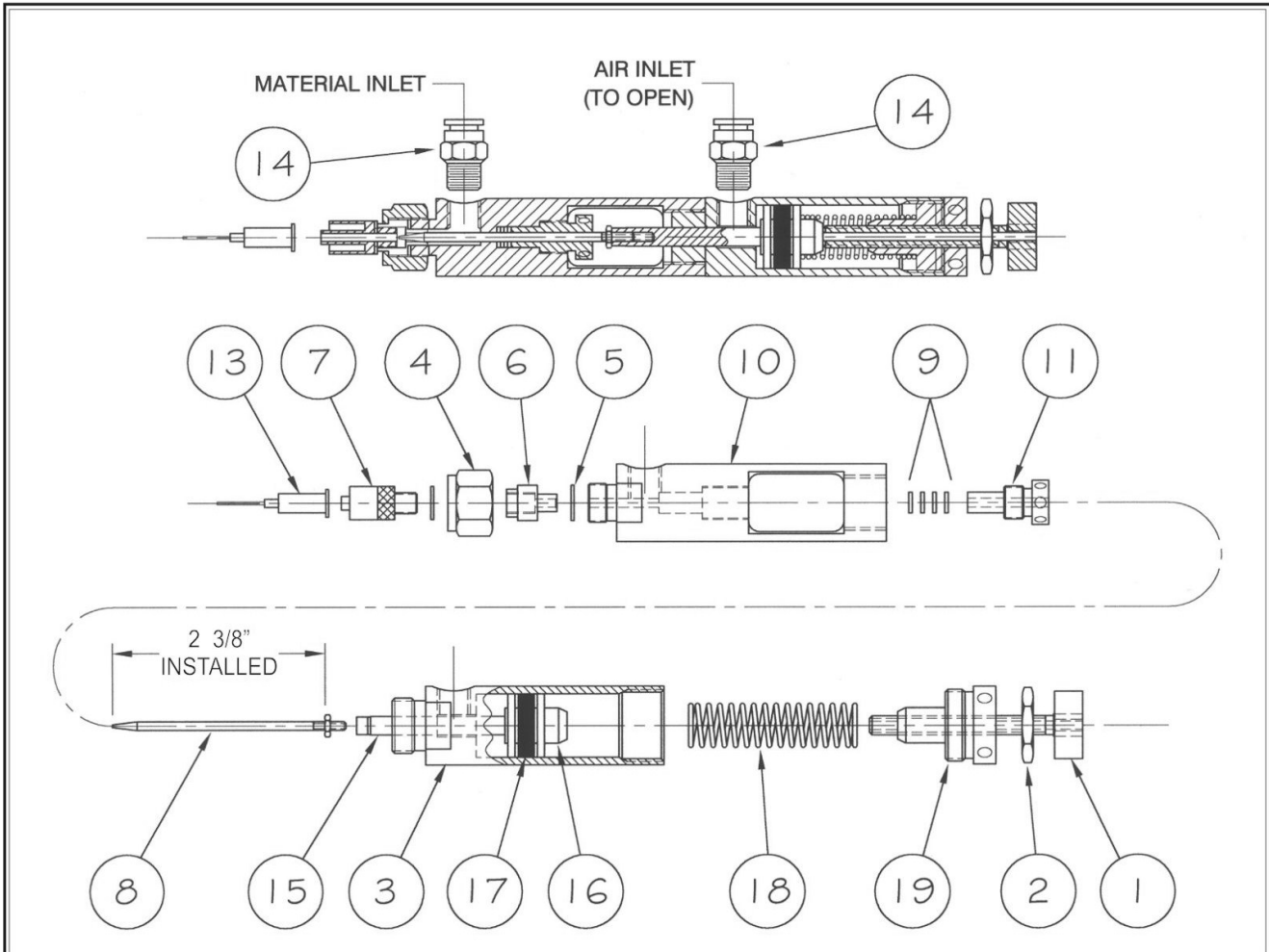

NO.	PART NUMBER	DESCRIPTION	QTY.	NO.	PART NUMBER	DESCRIPTION	QTY.
11	MV-024LF	NUT, PACKING	1				
10	MV-023LF	BODY, VALVE	1	**	560524	6 FT. CONNECTING HOSE	1
9	MV-022LF	PACKING ASSEMBLY	1	19*	MV-033LF	SPRING HOLDER	1
8	MV-028LF	PLUNGER WITH NUT	1	18*	MV-032LF	SPRING	1
7	MV-013LF	HOLDER, NEEDLE	1	17*	MV-031LF	U-CUP SEAL	1
6	MV-012LF	SEAT	1	16*	MV-030LF	PISTON	1
5	MV-011LF	WASHER	2	15*	MV-029LF	PISTON ROD	1
4	MV-010LF	NUT	1	14	561694	PUSH TYPE CONNECTOR	2
3	MV-003LF	CYLINDER	1	13	561836	ASSORTED TIPS	1
2	MV-002LF	LOCK NUT	1	12**	MV-025LF	TOOL, PACKING	1
1	MV-001LF	SCREW, ADJUSTING	1				

* THESE PARTS ARE ONLY AVAILABLE AS AN ASSEMBLY, PART No MV-003LF

** NOT SHOWN

DRAWN BY: DARKO KITANSKI	DATE DRAWN: 11/09/2006	FILE NAME: MV0180LF.CDR
-----------------------------	---------------------------	----------------------------

MODEL NO. 561716 OPTIONAL "GUN" HANDLE FOR MINI VALVES

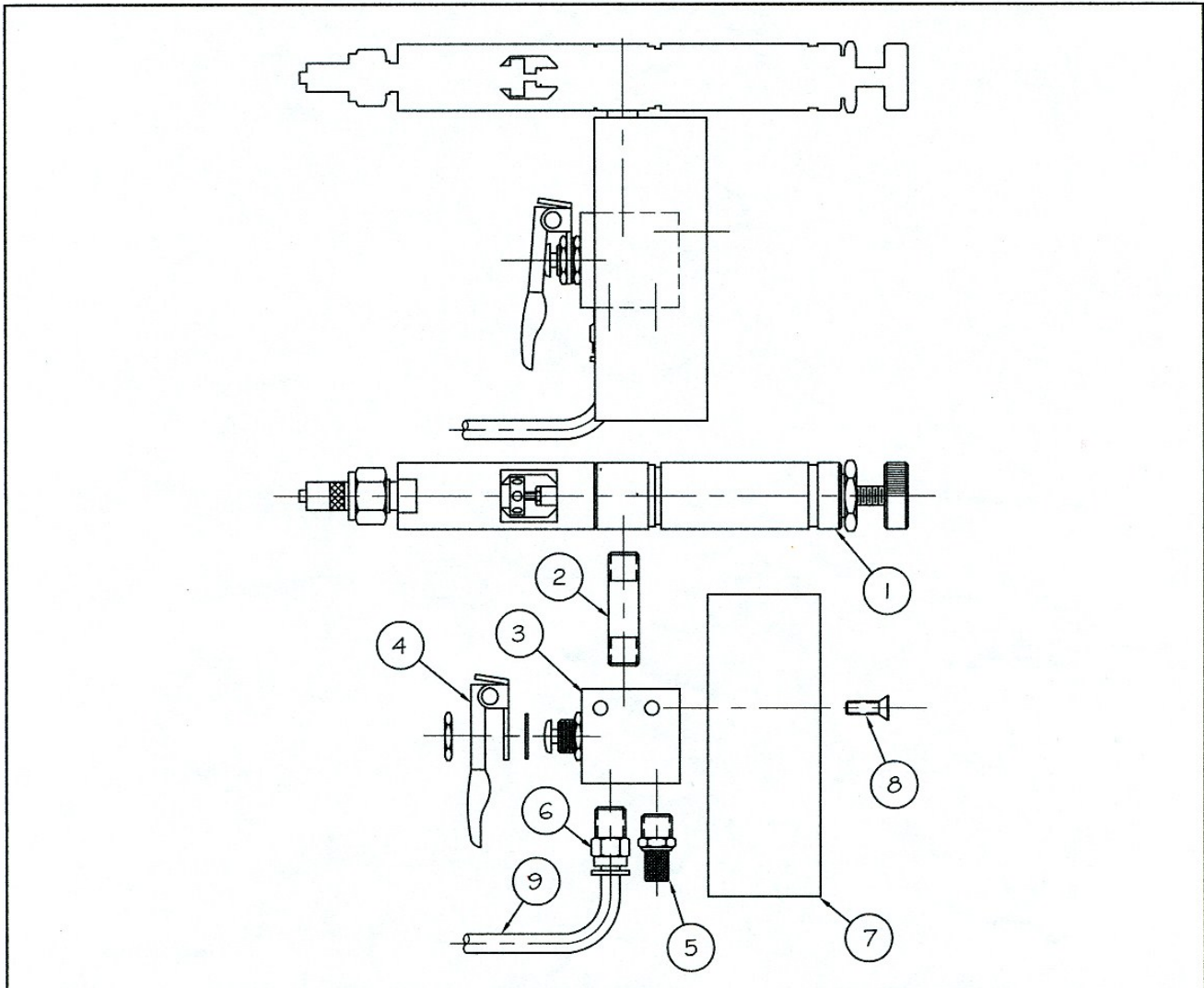

NO.	PART NUMBER	DESCRIPTION	QTY.
9	561415	TUBE, 1/4"	-
8	561712	SCREW	1
7	561715	HANDLE, COVER	1
6	561406	PUSH FITTING	1
5	561714	SILENCER	1
4	561711	TRIGGER w/STAR WASHER AND NUT	1
3	561710	AIR VALVE	1
2	561713	NIPPLE	1
1	MV-0180LF	MINI VALVE	1

This Page Intentionally Left Blank



15 Corporate Drive, Suite E - Wayne - NJ 07470
Tel: (973) 646-5044 E-mail: info@fisnar.com
www.fisnar.com