

GN 115

Latches

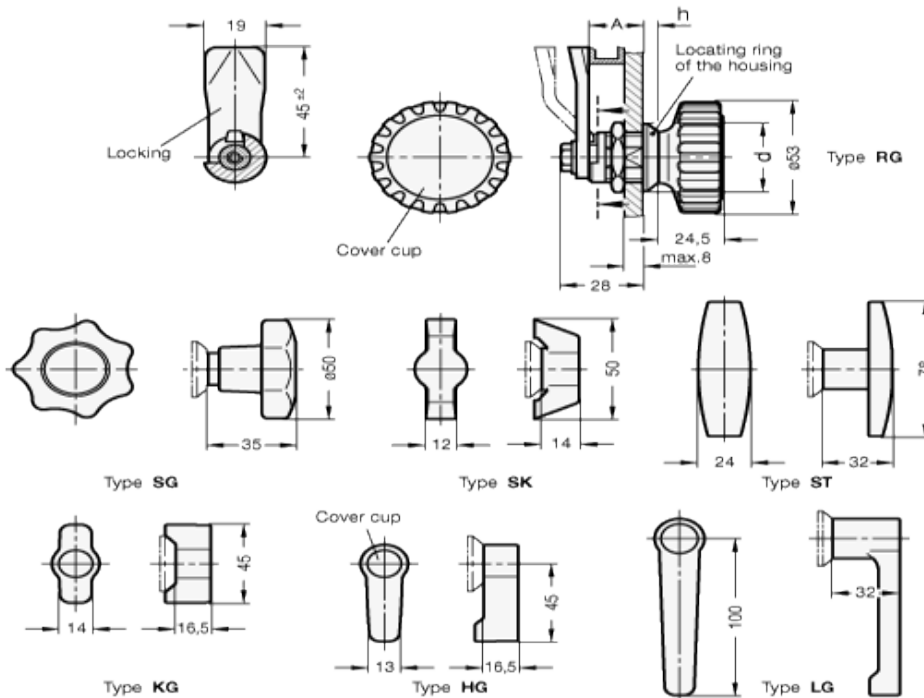

technical informations

Lock housing versions
Zinc alloy die-cast.

Finish

- Chromium-plated (standard).
- RAL 9005 black colour SW, matte finish, epoxy resin coating.

Metal elements

Zinc-plated steel, blue passivated.

Operating handles

Plastic, polyamide (PA), black matte finish.

Cover caps

Light grey (type RG, KG, HG).

Standard versions available

- Type DK: Operation with triangular spindle.
- Type VK7: Operation with square spindle A/F7.
- Type VK8: Operation with square spindle A/F8.
- Type SCH: Operation with slot.
- Type VDE: Operation with double bit.
- Type SG: Operation with DIN 6336 polyamide-based (PA) technopolymer star knob with tapped blind hole.
- Type SK: Operation with polyamide-based (PA) technopolymer wrench.
- Type ST: Operation with polyamide-based (PA) technopolymer with T-handle.
- Type RG: with knurled knob (GN 7336).
- Type KG: with wrench.
- Type HG: with lever.
- Type LG: Operation with lever handle.

Accessories on request

- Key GN 119.2.
- Protective caps GN 120.
- Opening handles GN 320.

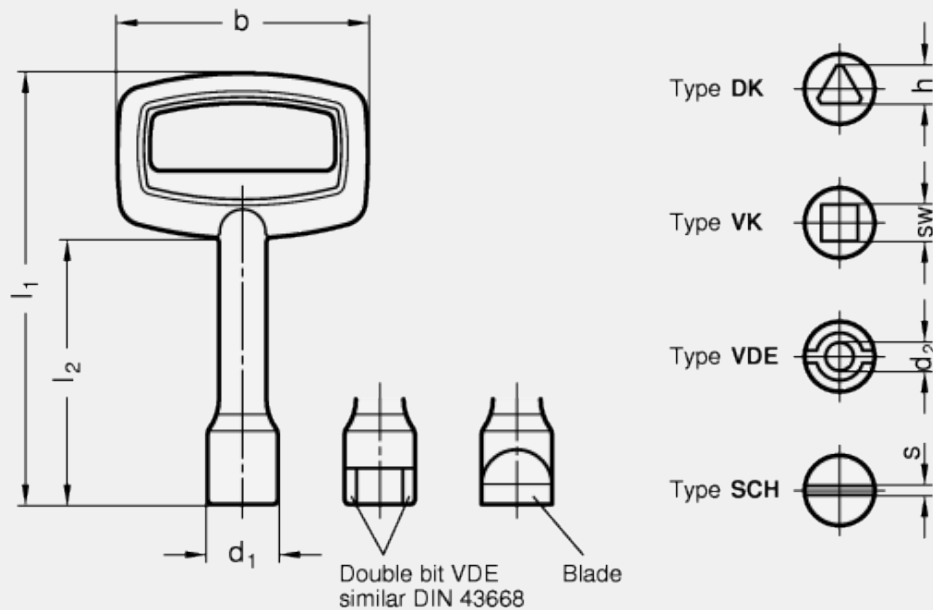

Assembly instructions

Latches GN 115 lock by a turning operation limited to 90° which moves the locking behind the door frame. The bevels of the latch ease the closing of the door.

Latches with 22 different cranks cover a latch distance A from 4 to 50 mm.

Latches GN 115 are supplied with loosely enclosed locking.

Features and applications

GN 115 latches are low cost. They offer a straightforward locking action rather than a locking and clamping action. The choice of 22 differently shaped catch plates gives a range A (see table on the following page) from 4 to 50 mm.

Construction and assembly instructions

For installation, set a bore diameter in the door as shown in the drawing opposite.

Once assembled, the latch is pushed through the bore diameter from the front. The hexagon nut can then be pushed over the latch from the back and bolted in place. The installation bore diameter in the door leaf is usually generated by punching or laser machining in series production. For small series and steel sheets below 2 mm thickness, the sheet metal punches GN 123 are the tool of choice. The installation bore diameter can also be set by drilling / milling as shown in the drawings.

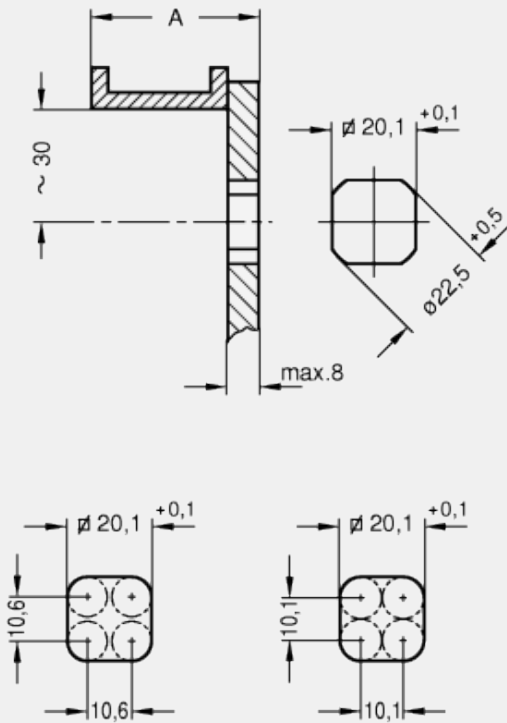

Standard Elements	Main dimensions			Weight
	A	d	h	g#
Description				
GN 115-*-4	4	28	4	120
GN 115-*-6	6	28	4	120
GN 115-*-8	8	28	4	120
GN 115-*-10	10	28	4	130
GN 115-*-13	13	28	4	130
GN 115-*-14	14	28	4	130
GN 115-*-16	16	28	4	130
GN 115-*-18	18	28	4	130
GN 115-*-20	20	28	4	130
GN 115-*-22	22	28	4	130
GN 115-*-24	24	28	4	130
GN 115-*-26	26	28	4	130
GN 115-*-28	28	28	4	130
GN 115-*-30	30	28	4	130
GN 115-*-32	32	28	4	135
GN 115-*-34	34	28	4	135
GN 115-*-36	36	28	4	135
GN 115-*-38	38	28	4	135
GN 115-*-40	40	28	4	140
GN 115-*-42	42	28	4	140

GN 115-*-45	45	28	4	140
GN 115-*-50	50	28	4	145

*Complete the description of the standard item needed by adding SG (with star knob), DK (with triangular spindle), VK7 (with square spindle A/F7), VK8 (with square spindle A/F8), VDE (with double bit), SCH (with slot), RG (with knurled knob GN 7336), KG (with wrench), HG (with lever) or LG (Operation with lever handle)

#Weight type SG.

Standard Elements	Main dimensions			Weight
Description	A	d	h	g
GN 115-*-4	4	32	6	27
GN 115-*-6	6	32	6	27
GN 115-*-8	8	32	6	28
GN 115-*-10	10	32	6	27
GN 115-*-13	13	32	6	27
GN 115-*-14	14	32	6	28
GN 115-*-16	16	32	6	27
GN 115-*-18	18	32	6	27
GN 115-*-20	20	32	6	27
GN 115-*-22	22	32	6	26
GN 115-*-24	24	32	6	27
GN 115-*-26	26	32	6	28
GN 115-*-28	28	32	6	29
GN 115-*-30	30	32	6	30
GN 115-*-32	32	32	6	29
GN 115-*-34	34	32	6	32
GN 115-*-36	36	32	6	30
GN 115-*-38	38	32	6	35
GN 115-*-40	40	32	6	38
GN 115-*-42	42	32	6	37
GN 115-*-45	45	32	6	39
GN 115-*-50	50	32	6	42

* Complete the description of the standard item needed by adding SK (with wrench) or ST (with T-Handle).

Standard Elements	Main dimensions			Weight #
Description	A	d	h	g
GN 115-*-4-SW	4	28	4	120
GN 115-*-6-SW	6	28	4	120
GN 115-*-8-SW	8	28	4	120
GN 115-*-10-SW	10	28	4	130
GN 115-*-13-SW	13	28	4	130
GN 115-*-14-SW	14	28	4	130
GN 115-*-16-SW	16	28	4	130
GN 115-*-18-SW	18	28	4	130
GN 115-*-20-SW	20	28	4	130
GN 115-*-22-SW	22	28	4	130
GN 115-*-24-SW	24	28	4	130
GN 115-*-26-SW	26	28	4	130

GN 115-* -28-SW	28	28	4	130
GN 115-* -30-SW	30	28	4	130
GN 115-* -32-SW	32	28	4	135
GN 115-* -34-SW	34	28	4	135
GN 115-* -36-SW	36	28	4	135
GN 115-* -38-SW	38	28	4	135
GN 115-* -40-SW	40	28	4	140
GN 115-* -42-SW	42	28	4	140
GN 115-* -45-SW	45	28	4	140
GN 115-* -50-SW	50	28	4	145

*Complete the description of the standard item needed by adding SG (with star knob), DK (with triangular spindle), VK7 (with square spindle A/F7), VK8 (with square spindle A/F8), VDE (with double bit), SCH (with slot), RG (with knurled knob GN 7336), KG (with wrench), HG (with lever) or LG (Operation with lever handle)

Weigth type SG.

Standard Elements	Main dimensions			Weight
Description	A	d	h	g
GN 115-* -4-SW	4	32	6	27
GN 115-* -6-SW	6	32	6	27
GN 115-* -8-SW	8	32	6	28
GN 115-* -10-SW	10	32	6	27
GN 115-* -13-SW	13	32	6	27
GN 115-* -14-SW	14	32	6	28
GN 115-* -16-SW	16	32	6	27
GN 115-* -18-SW	18	32	6	27
GN 115-* -20-SW	20	32	6	27
GN 115-* -22-SW	22	32	6	26
GN 115-* -24-SW	24	32	6	27
GN 115-* -26-SW	26	32	6	28
GN 115-* -28-SW	28	32	6	29
GN 115-* -30-SW	30	32	6	30
GN 115-* -32-SW	32	32	6	29
GN 115-* -34-SW	34	32	6	32
GN 115-* -36-SW	36	32	6	30
GN 115-* -38-SW	38	32	6	35
GN 115-* -40-SW	40	32	6	38
GN 115-* -42-SW	42	32	6	37
GN 115-* -45-SW	45	32	6	39
GN 115-* -50-SW	50	32	6	42

* Complete the description of the standard item needed by adding SK (with wrench) or ST (with T-Handle).

