

BN 1719

Cross recessed pan head assembled
screws
Phillips H, with captive flat washer
DIN 6902 A

DIN 7985 Z1

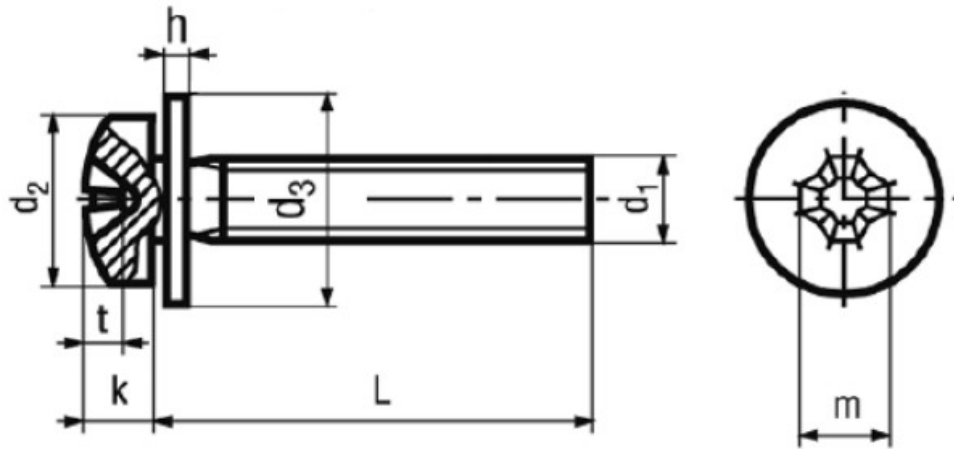

Material	Steel	Tensile strength	400 N/mm ²
Surface	zinc plated blue	Elongation after fracture	min. 14%
Quality	4.8		

Article No. - 1370189

d ₁	M4
L	10
d ₂ max.	8
k max.	3,25
Phillips	2
t min.	2,04
t max.	2,54
m~	4,6
d ₃	
h	0,8