

# GN 425.2

Folding handles

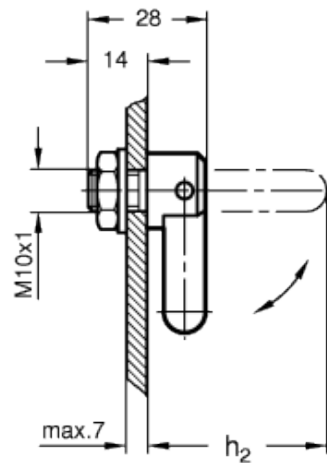

INOX  
Stainless Steel

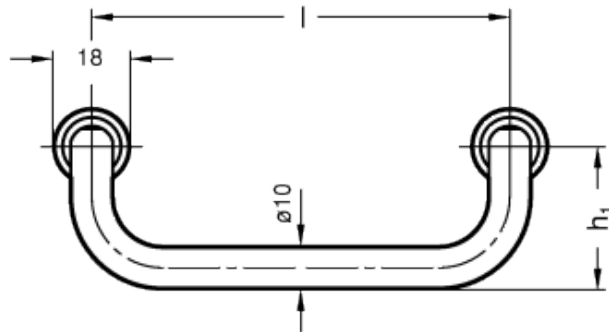

technical informations

**Material**

Round cross section bar, chromium-plated finish CR.

### Assembly

Back mounting by means of two ISO 8675-M10x1 hexagon nuts and DIN 125 zinc-plated steel washers.

### Stop spring

To keep the handle open or folded back.

### Features

GN 425.2 folding handles are particularly suitable where minimal protrusion is required.

Standard Elements	Main dimensions			Weight
Description	$l \pm 0.25$	$h_1$	$h_2$	g
GN 425.2-100-CR	100	34	43	150
GN 425.2-120-CR	120	34	43	162
GN 425.2-180-CR	180	34	43	200



STANDARD MACHINE ELEMENTS WORLDWIDE