

Temperature and wear resistant, FDA-compliant – iglidur® A350



Standard range from stock

The iglidur® A350 material complies with FOOD AND DRUG ADMINISTRATION (FDA) regulations

For use with temperatures up to +180 °C

For medium and high loads

Equally good for both oscillating and rotating applications

iglidur® A350

Temperature and wear resistant, FDA-compliant. A very universal bearing for use in the area of food and pharmaceutical industries. Composition of FDA-conform materials allows the use in areas where due to the contact with food other bearings cannot be used. With good tribological and mechanical properties, iglidur® A350 bearings are suitable for general purpose use in food machinery. The blue colour helps to visually identify the bearing, an important factor when designing food processing equipment.

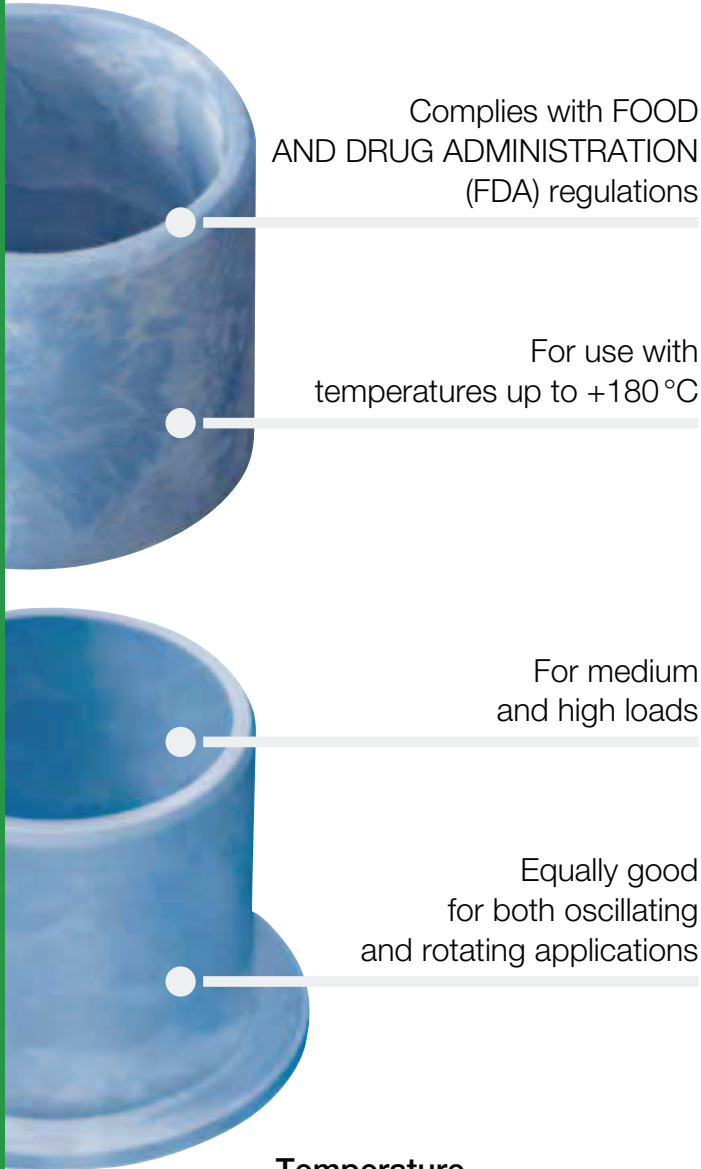

Temperature

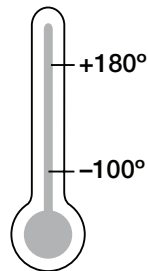

When to use it?

- If FDA-compliance is required
- If wear-resistance and FDA-conformance is necessary at high loads
- If the bearing is use in acid environment
- If a blue bearing is required



When not to use?

- When temperatures are continuously greater than +180 °C
 - ▶ iglidur® A500, page 457
- When the maximum abrasion resistance is necessary
 - ▶ iglidur® J, page 109
- When a low-priced FDA bearing is required
 - ▶ iglidur® A200, page 431
 - ▶ iglidur® A180, page 411
- For high speeds
 - ▶ iglidur® J, page 109

Product range

2 types
 Ø 6–50 mm
 more dimensions
 on request



iglidur® A350 products comply with the requirements of the FDA for repeated contact with food



Material properties table

General properties	Unit	iglidur® A350	Testing method
Density	g/cm ³	1.42	
Colour		blue	
Max. moisture absorption at +23 °C/50 % r.h.	% weight	0.6	DIN 53495
Max. water absorption	% weight	1.9	
Coefficient of sliding friction, dynamic against steel	μ	0.1–0.2	
pv value, max. (dry)	MPa · m/s	0.4	
Mechanical properties			
Modulus of elasticity	MPa	2,000	DIN 53457
Tensile strength at +20 °C	MPa	110	DIN 53452
Compressive strength	MPa	78	
Max. recommended surface pressure (+20 °C)	MPa	60	
Shore D hardness		76	DIN 53505
Physical and thermal properties			
Max. long term application temperature	°C	+180	
Max. short term application temperature	°C	+210	
Min. application temperature	°C	-100	
Thermal conductivity	W/m · K	0.24	ASTM C 177
Coefficient of thermal expansion (at +23 °C)	K ⁻¹ · 10 ⁻⁵	8	DIN 53752
Electrical properties			
Specific volume resistance	Ωcm	> 10 ¹¹	DIN IEC 93
Surface resistance	Ω	> 10 ¹¹	DIN 53482

Table 01: Material properties table

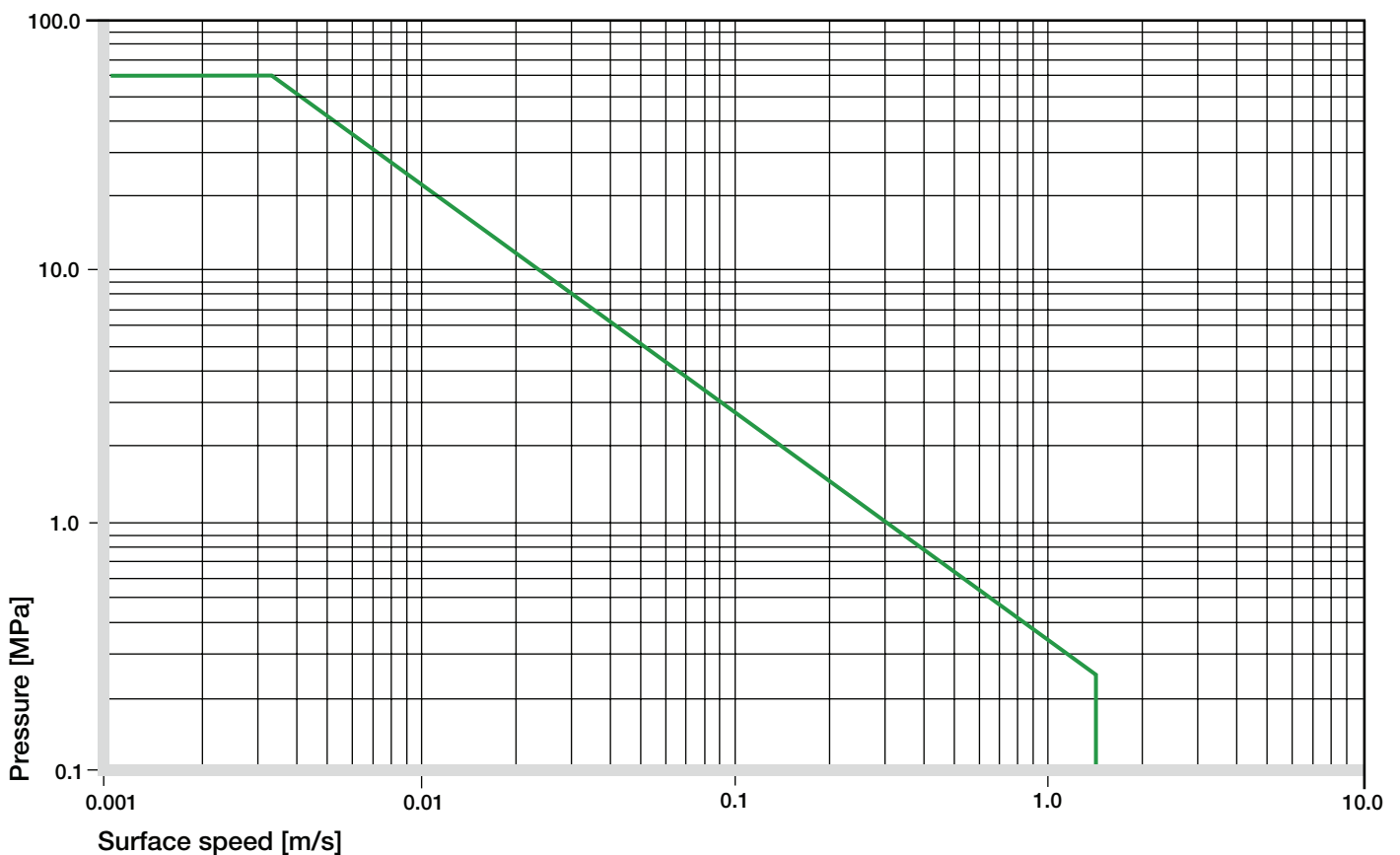

Diagram 01: Permissible pv values for iglidur® A350 with a wall thickness of 1 mm dry running against a steel shaft at +20 °C, mounted in a steel housing

iglidur® A350 bearings are made for practically all loads in food and packaging machinery. Even high loads, often seen in lifting equipment, are taken easily and the bearings work flawlessly without any external lubrication.

Mechanical Properties

With increasing temperatures, the compressive strength of iglidur® A350 plain bearings decreases. The Diagram 02 shows this inverse relationship. However, at the longterm maximum temperature of +180 °C the permissible surface pressure is 10 MPa. The recommended maximum surface pressure is a mechanical material parameter. No conclusions regarding the tribological properties can be drawn from this.

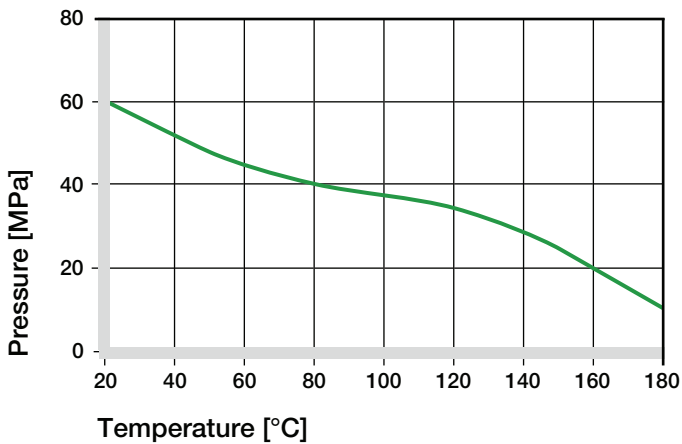

Diagram 02: Recommended maximum surface pressure as a function of temperature (60 MPa at +20 °C)

Diagram 03 shows the elastic deformation of iglidur® A350 at radial loads. At the recommended maximum surface pressure of 60 MPa the deformation is less than 5 %.

► Surface Pressure, page 63

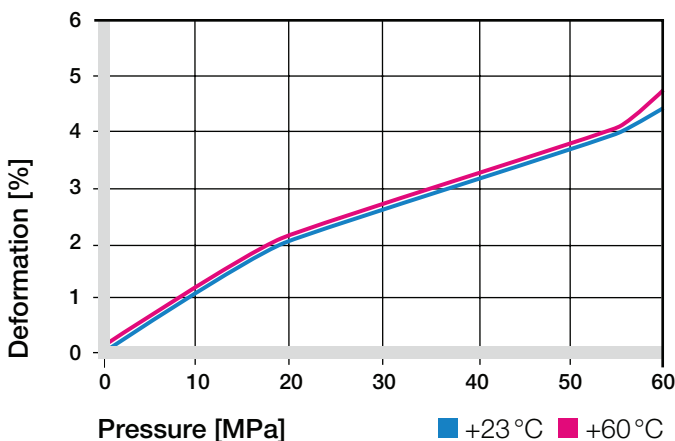

Diagram 03: Deformation under pressure and temperature

Permissible Surface Speeds

iglidur® A350 bearings are suitable for low to medium speeds in both rotating and oscillating applications. Even linear movements can often be realised with iglidur® A350. With high sliding speeds, iglidur® J or iglidur® L250 can be interesting alternatives because the wear rate of these materials is better.

► Surface Speed, page 65

m/s	Rotating	Oscillating	Linear
Continuous	1	0.8	2.5
Short term	1.2	0.9	3

Table 02: Maximum running speed

Temperatures

Its temperature resistance makes iglidur® A350 an ideal material for bearing in the area of foodstuffs. Typically, temperatures range up to +130 °C, which corresponds perfectly with the applicable temperature range for iglidur® A350. Short-term temperatures up to +210 °C are possible. Please note that at temperatures over +140 °C, the pressfit forces of the bearings may decrease and an additional axial security device is recommended.

The wear-rate of iglidur® A350 bearings rises only little with higher temperatures. Tests have shown good wear results at +100 °C on all tested shaft materials.

► Application Temperatures, page 66

iglidur® A350	Application temperature
Minimum	-100 °C
Max. long term	+180 °C
Max. short term	+210 °C
Add. securing is required from	+140 °C

Table 03: Temperature limits

Friction and Wear

The coefficient of friction of iglidur® A350 on a steel shaft are in the mid range. They decrease at higher temperatures, which in dry operation is somewhat unusual. Diagram 04 shows this phenomenon graphically.

All wear results of iglidur® A350 bearings show good results on a low level. Of all iglidur® materials for food contact, they are often the best choice.

- ▶ Coefficients of Friction and Surfaces, **page 68**
- ▶ Wear Resistance, **page 69**

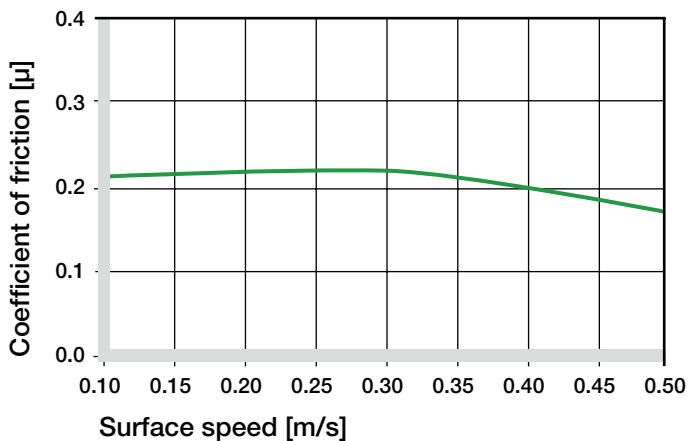

Diagram 04: Coefficient of friction as a function of the running speed, $p = 1 \text{ MPa}$

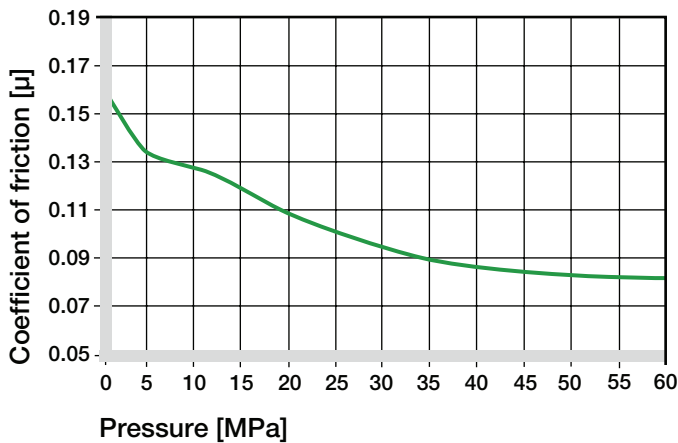

Diagram 05: Coefficient of friction as a function of the pressure, $v = 0.01 \text{ m/s}$

Shaft Materials

The corrosion-resistant steels are rather considered a natural choice for use in the food industry.

The trials were therefore carried out especially on such materials. It has been shown that there is no clear favorite and V2A, X90 and hard chrome plated steel are all suitable. Hard-anodized aluminum is also well suited for both linear and rotating movements.

- ▶ Shaft Materials, **page 71**

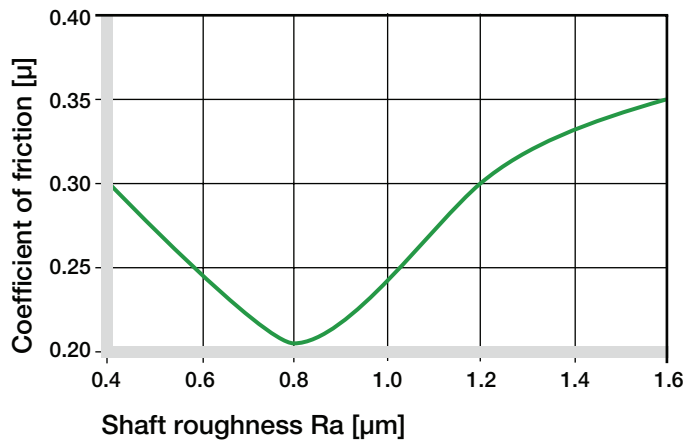

Diagram 06: Coefficient of friction as function of the shaft surface (Cf53 hardened and ground steel)

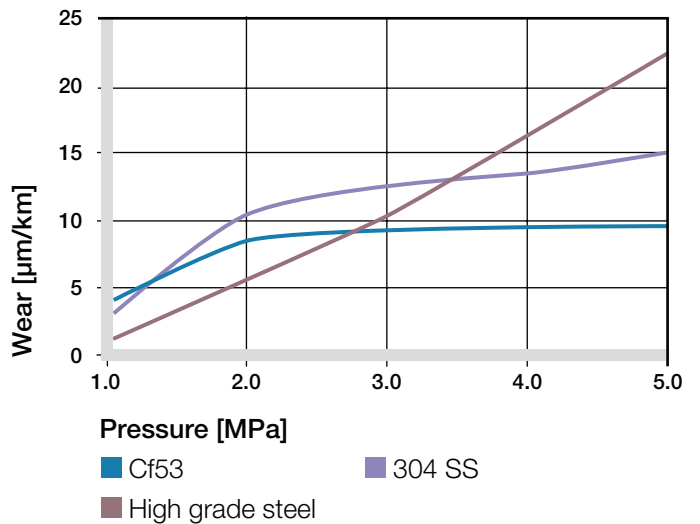

Diagram 07: Wear with different shaft materials in rotational operation, as a function of the pressure

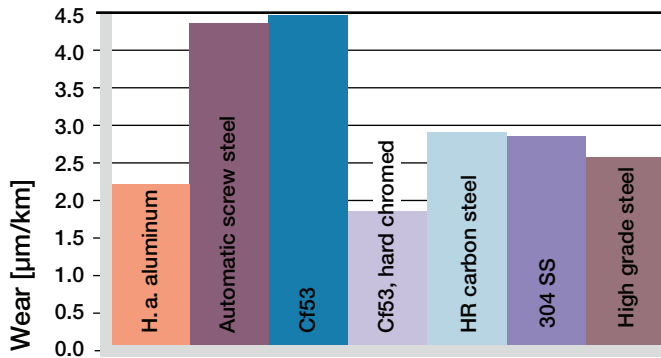

Diagram 08: Wear, rotating with different shaft materials, pressure $p = 1 \text{ MPa}$, $v = 0.3 \text{ m/s}$

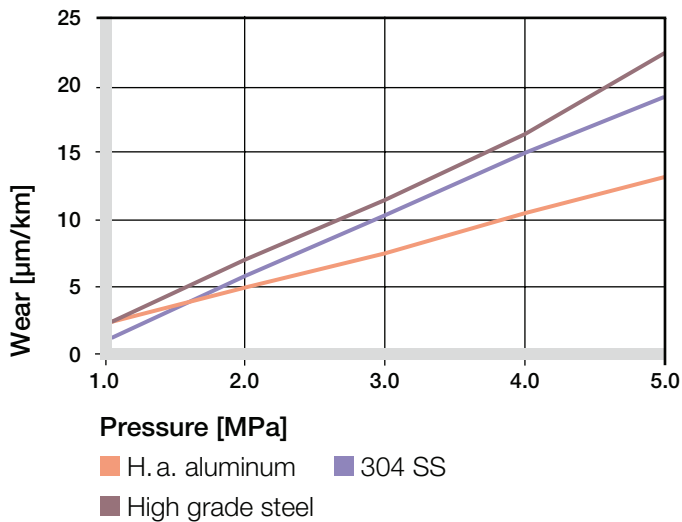

Diagram 09: Wear with different shaft materials in oscillating operation, as a function of the pressure

iglidur® A350	Dry	Greases	Oil	Water
C.o.f. μ	0.1–0.2	0.09	0.04	0.04

Table 04: Coefficient of friction against steel ($R_a = 1 \text{ }\mu\text{m}$, 50 HRC)

Additional Properties

Chemical Resistance

iglidur® A350 plain bearings are resistant to diluted acids and alkalis, alcohols and detergents. They are also resistant to most lubricants. The iglidur® A350 plain bearings are resistant to common cleaning agents in the food industry. iglidur® A350 is affected by esters, ketones, chlorinated hydrocarbons, aromatics and highly polar solvents.

► Chemical Table, page 1258

Medium	Resistance
Alcohol	+
Hydrocarbons	+ to 0
Greases, oils without additives	+
Fuels	+
Diluted acids	+
Strong acids	+
Diluted alkalines	+
starke Basen	+

+ resistant 0 conditionally resistant – not resistant

All data given at room temperature [+20 °C]

Table 05: Chemical resistance

Radiation Resistance

Plain bearings made of iglidur® A350 are resistant to radiation up to an intensity of $2 \cdot 10^2 \text{ Gy}$.

UV Resistance

iglidur® A350 bearings are resistant to UV radiation.

Vacuum

When used in a vacuum environment, the iglidur® A350 plain bearings release moisture as a vapour. Therefore, only dehumidified bearings are suitable in a vacuum environment.

Electrical Properties

iglidur® A350 plain bearings are electrically insulating.

Volume resistance	$> 10^{11} \text{ }\Omega\text{cm}$
Surface resistance	$> 10^{11} \text{ }\Omega$

iglidur® A350 | Technical Data

Moisture Absorption

The moisture absorption of iglidur® A350 is low and can be disregarded when using standard bearings.

Even at full saturation the iglidur® A350 does not absorb more than 1.9% of water.

Maximum moisture absorption

At +23 °C/50% r.h. 0.6% weight

Max. water absorption 1.9% weight

Table 06: Moisture absorption

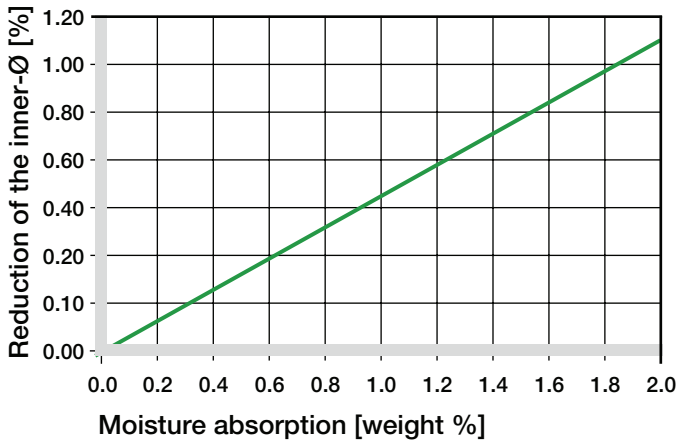

Diagram 10: Effect of moisture absorption on plain bearings

Installation Tolerances

iglidur® A350 plain bearings are standard bearings for shafts with h-tolerance (recommended minimum h9). The bearings are designed for pressfit into a housing machined to a H7 tolerance. After being assembled into a nominal size housing, in standard cases the inner diameter automatically adjusts to the F10 tolerances. For particular dimensions the tolerance differs depending on the wall thickness (please see product range table).

► Testing Methods, page 75

Diameter d1 [mm]	Shaft h9 [mm]	iglidur® A350 F10 [mm]	Housing H7 [mm]
up to 3	0-0.025	+0.006 +0.046	0 +0.010
> 3 to 6	0-0.030	+0.010 +0.058	0 +0.012
> 6 to 10	0-0.036	+0.013 +0.071	0 +0.015
> 10 to 18	0-0.043	+0.016 +0.086	0 +0.018
> 18 to 30	0-0.052	+0.020 +0.104	0 +0.021
> 30 to 50	0-0.062	+0.025 +0.125	0 +0.025
> 50 to 80	0-0.074	+0.030 +0.150	0 +0.030

Table 07: Important tolerances for plain bearings according to ISO 3547-1 after pressfit

Sleeve bearing

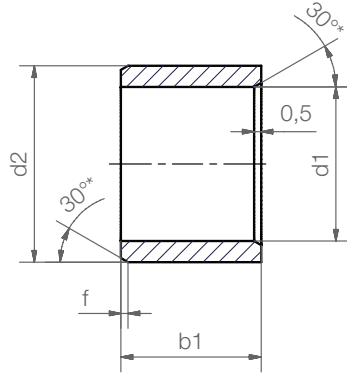

Order key

A350SM-0608-06



- Length b1
- Outer diameter d2
- Inner diameter d1
- Metric
- Type (Form S)
- Material iglidur® A350

Dimensions according to ISO 3547-1 and special dimensions

* thickness < 1 mm, chamfer = 20°

Chamfer in relation to the d1

d1 [mm]:	Ø 1-6	Ø 6-12	Ø 12-30	Ø > 30
f [mm]:	0.3	0.5	0.8	1.2

Dimensions [mm]

Part number	d1	d1-Tolerance*	d2	b1 h13
A350SM-0608-06	6.0	+0.010 +0.058	8.0	6.0
A350SM-0810-10	8.0	+0.013 +0.071	10.0	10.0
A350SM-1012-10	10.0	+0.013 +0.071	12.0	10.0
A350SM-1214-12	12.0	+0.016 +0.068	14.0	12.0
A350SM-1618-15	16.0	+0.016 +0.068	18.0	15.0
A350SM-1618-25	16.0	+0.016 +0.068	18.0	25.0
A350SM-2023-20	20.0	+0.020 +0.104	23.0	20.0
A350SM-2023-30	20.0	+0.020 +0.104	23.0	30.0
A350SM-2832-30	28.0	+0.020 +0.104	32.0	30.0
A350SM-3236-40	32.0	+0.025 +0.125	36.0	40.0
A350SM-4044-50	40.0	+0.025 +0.125	44.0	50.0
A350SM-5055-50	50.0	+0.025 +0.125	55.0	50.0

* after pressfit. Testing methods ► page 75



delivery from stock
time



prices price list online
www.igus.eu/eu/a350

iglidur® A350 | Product Range

Flange bearing

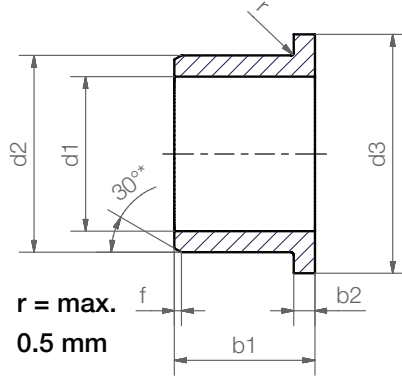

r = max.
0.5 mm



Order key

A350FM-0608-06



Length b1
Outer diameter d2
Inner diameter d1
Metric
Type (Form F)
Material iglidur® A350

Dimensions according to ISO 3547-1 and special dimensions

* thickness < 1 mm, chamfer = 20°

Chamfer in relation to the d1

d1 [mm]:	Ø 1-6	Ø 6-12	Ø 12-30	Ø > 30
f [mm]:	0.3	0.5	0.8	1.2

Dimensions [mm]

Part number	d1	d1-Tolerance*	d2	d3 d13	b1 h13	b2 -0.14
A350FM-0608-06	6.0	+0.010 +0.058	8.0	12.0	6.0	1.0
A350FM-0810-10	8.0	+0.013 +0.071	10.0	15.0	10.0	1.0
A350FM-1012-10	10.0	+0.013 +0.071	12.0	18.0	10.0	1.0
A350FM-1214-12	12.0	+0.016 +0.068	14.0	20.0	12.0	1.0
A350FM-1618-17	16.0	+0.016 +0.068	18.0	24.0	17.0	1.0
A350FM-2023-21	20.0	+0.020 +0.104	23.0	30.0	21.5	1.5
A350FM-3539-26	35.0	+0.025 +0.125	39.0	47.0	26.0	2.0

* after pressfit. Testing methods ► page 75



Don't find your size?

Do you need another length, other dimensions or tolerances? You need a particular design or alternative for your application? Please call us. igus® listens to your needs and provides you a solution in a very short time.



delivery from stock
time



prices price list online
www.igus.eu/eu/a350