

The food grade material, compliant to FDA and per EC Directive 10/2011 EC – iglidur® A181



Standard range from stock

Compliant per EC Directive 10/2011 EC

FDA compliant

Universally applicable

Good media resistance

Wear resistant

Lubrication and maintenance-free

The food grade material. The iglidur® A181 material is food compliant per Directive 10/2011 EC and also to FDA specifications. The blue colour also facilitates the often desired “optical detectability” in the food industry.

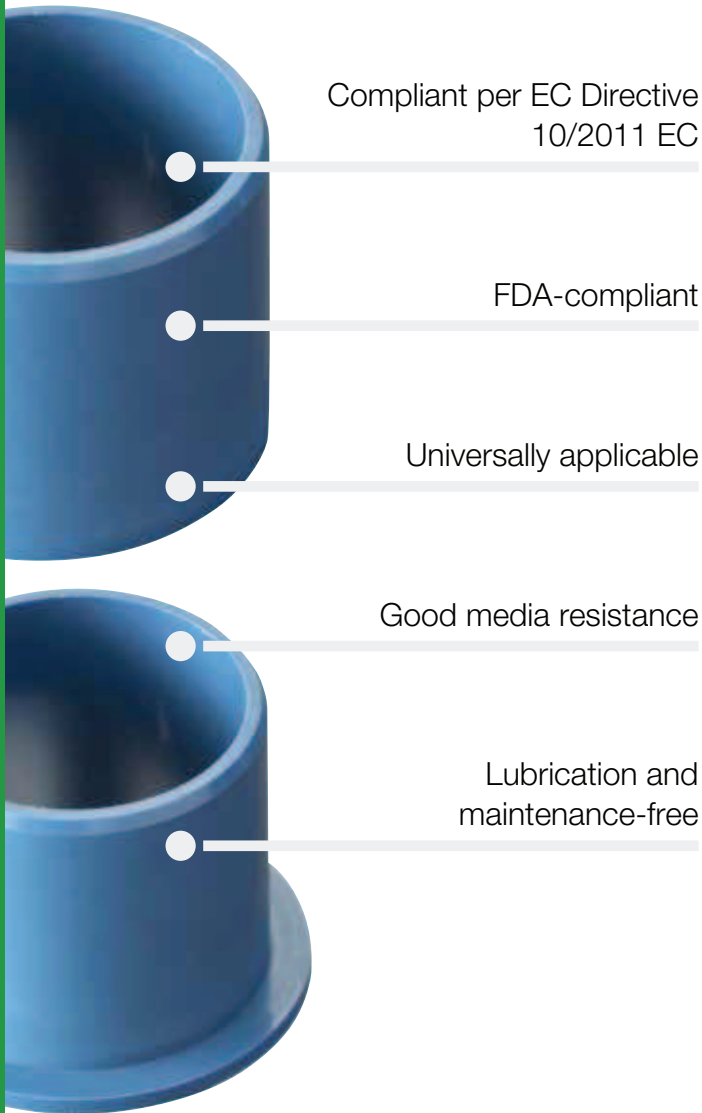

When to use it?

- When FDA compliance is required
- When a compliant per Directive 10/2011EG material is required
- When an universal material suitable for direct contact with food is sought



When not to use?

- When FDA and 10/2011 EG Directive compliance are not required
 - ▶ iglidur® J, page 109
- When temperatures are continuously greater than +90 °C
 - ▶ iglidur® A350, page 447
- When a cost-effective universal bearing is required
 - ▶ iglidur® G, page 81
 - ▶ iglidur® P, page 195

Temperature

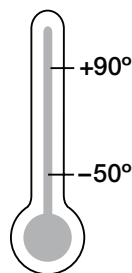

Product Range

2 types
 Ø 6–20 mm
 more dimensions
 on request



The products made of iglidur® A181 are food compliant per Directive 10/2011 EC and also to FDA specifications for repeated contact with food



Material properties table

General properties	Unit	iglidur® A181	Testing Method
Density	g/cm ³	1.38	
Colour		blue	
Max. moisture absorption at +23 °C/50 % r.h.	% weight	0.2	DIN 53495
Max. water absorption	% weight	1.3	
Coefficient of sliding friction, dynamic against steel	μ	0.18–0.21	
pv value, max. (dry)	MPa · m/s	0.31	
Mechanical properties			
Modulus of elasticity	MPa	1,913	DIN 53457
Tensile strength at +20 °C	MPa	48	DIN 53452
Compressive strength	MPa	60	
Max. recommended surface pressure (+20 °C)	MPa	31	
Shore D hardness		76	DIN 53505
Physical and thermal properties			
Max. long term application temperature	°C	+90	
Max. short term application temperature	°C	+110	
Min. application temperature	°C	-50	
Thermal conductivity	W/m · K	0.25	ASTM C 177
Coefficient of thermal expansion (at +23 °C)	K ⁻¹ · 10 ⁻⁵	11	DIN 53752
Electrical properties			
Specific volume resistance	Ωcm	> 10 ¹²	DIN IEC 93
Surface resistance	Ω	> 10 ¹²	DIN 53482

Table 01: Material properties table

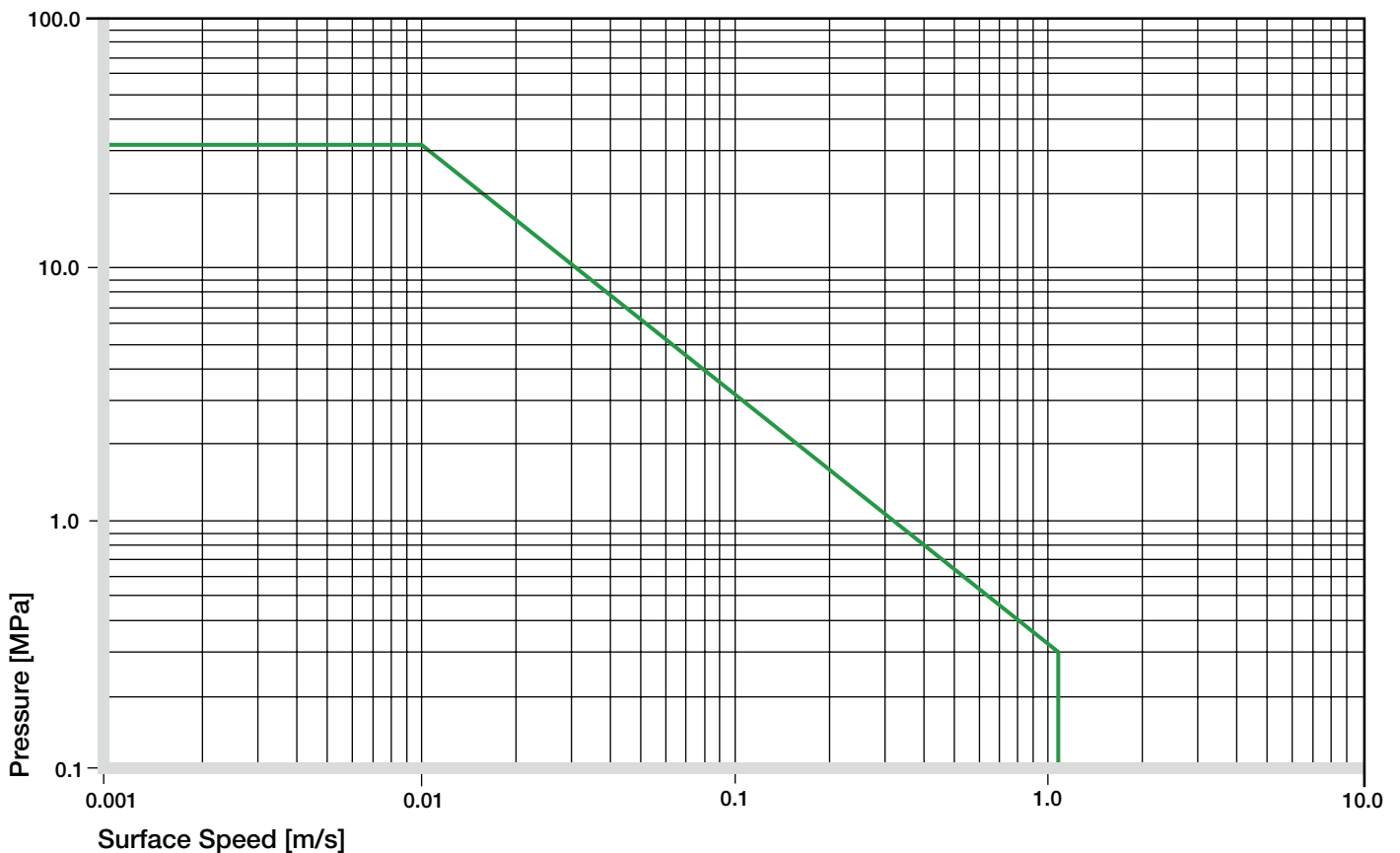

Diagram 01: Permissible pv values for iglidur® A181 with a wall thickness of 1 mm dry running against a steel shaft at +20 °C, mounted in a steel housing

Due to their technical properties and their conformity with the relevant regulations, iglidur® A181 bearings are predestined for applications in food technology. Compared to iglidur® A180 with regard to the mechanical properties, temperature and media resistance, iglidur® A181 is better suitable with respect the wear resistance in most cases.

Mechanical Properties

With increasing temperatures, the compressive strength of iglidur® A181 plain bearings decreases. The Diagram 02 shows this inverse relationship. At a temperature of +70 °C, the permitted surface pressure is still almost half of the initial value at room temperature. The recommended maximum surface pressure is a mechanical material parameter. No conclusions regarding the tribological properties can be drawn from this.

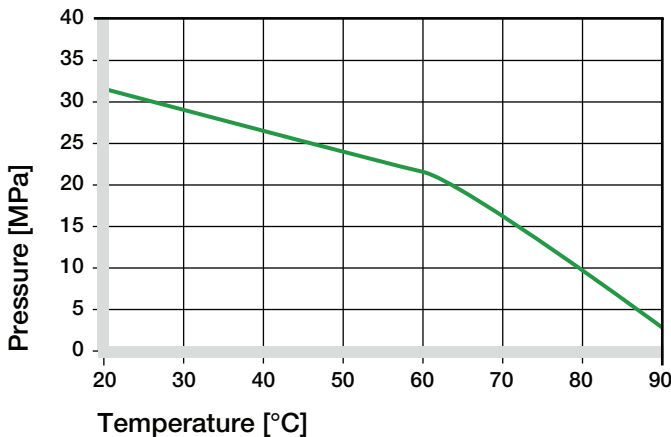

Diagram 02: Recommended maximum surface pressure as a function of temperature (31 MPa at +20 °C)

Diagram 03 shows the elastic deformation of iglidur® A181 during radial loading. At the recommended maximum surface pressure of 31 MPa the deformation is less than 3 % in standard atmosphere.

- Surface Pressure, [page 63](#)

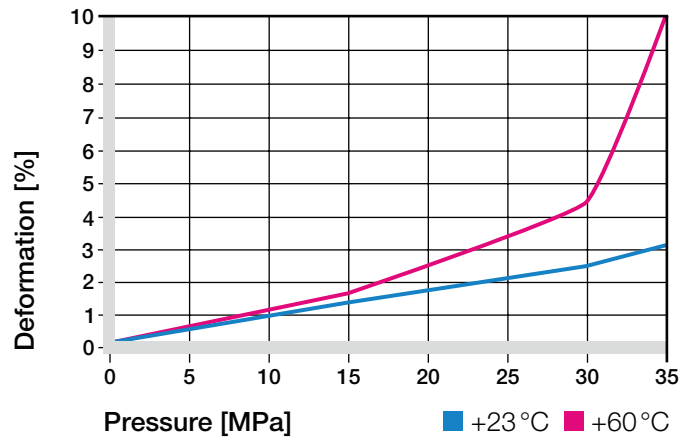

Diagram 03: Deformation under pressure and temperature

Permissible Surface Speeds

iglidur® A181 is developed for low surface speeds. Maximum speeds up to 0.8 m/s (rotating) and 3.5 m/s (linear) respectively are permitted for continuous application in dry operation.

These given values (table 02) indicate the limits at which an increase up to the continuous permissible temperature occurs. In practice these limit values are not always reached due to interactions.

- Surface Speed, [page 65](#)
- pv value and lubrication, [page 65](#)

m/s	Rotating	Oscillating	Linear
Continuous	0.8	0.6	3.5
Short term	1.2	1.0	5.0

Table 02: Maximum running speed

Temperatures

The longterm upper temperature limit of +90 °C permits the broad use in applications with direct contact with food. As shown in diagram 02, with increasing temperatures, the compressive strength decreases. When considering temperatures, the additional frictional heat in the bearing system must be taken into account.

- Application Temperatures, [page 66](#)

iglidur® A181	Application Temperature
Minimum	-50 °C
Max. long term	+90 °C
Max. short term	+110 °C
Add. securing is required from	+60 °C

Table 03: Temperature limits

iglidur® A181 | Technical Data

Friction and Wear

Coefficient of friction and wear resistance alter with the application parameters. For iglidur® A181 bearings, the alteration of the coefficient of friction μ depends on surface speed and the shaft surface finish is only negligently pronounced. With increasing load, the coefficient of friction however sinks markedly. The coefficient of friction perceptibly reduces straightaway in the load range up to 5 MPa.

- ▶ Coefficients of Friction and Surfaces, **page 68**
- ▶ Wear Resistance, **page 69**

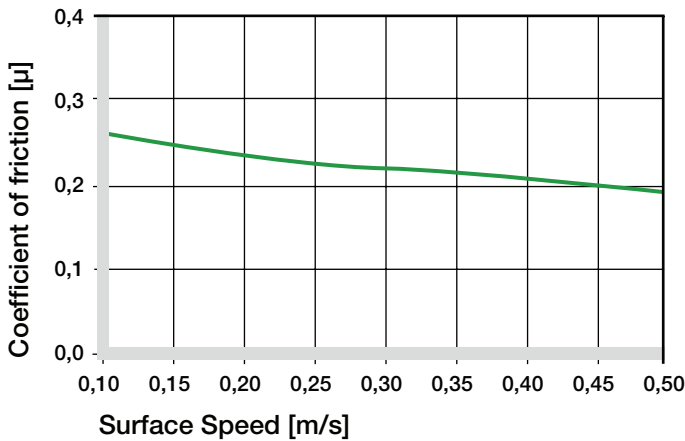

Diagram 04: Coefficient of friction as a function of the running speed, $p = 1.0$ MPa

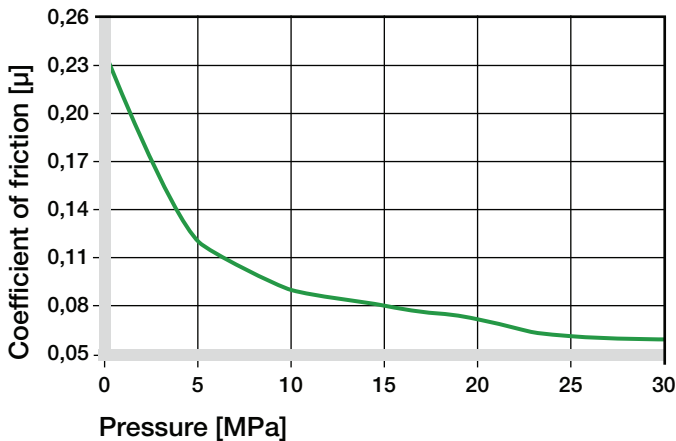

Diagram 05: Coefficient of friction as a function of the pressure, $v = 0.01$ m/s

Shaft Materials

Diagrams 06 to 09 show results of testing different shaft materials with plain bearings made of iglidur® A181. Particular attention is paid in the food industry to the corrosion-resistant shaft types. Diagram 08 shows that very low wear rates can be achieved in combination with these shafts. As with many of the iglidur materials, wear rate increases with otherwise identical parameters in rotation with the stressing stronger than during a pivoting movement (Diagram 09).

- ▶ Shaft Materials, **page 71**

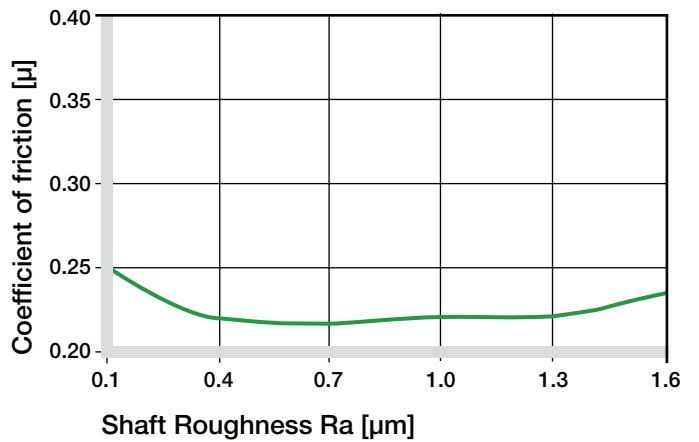

Diagram 06: Coefficient of friction as function of the shaft surface (Cf53 hardened and ground steel)

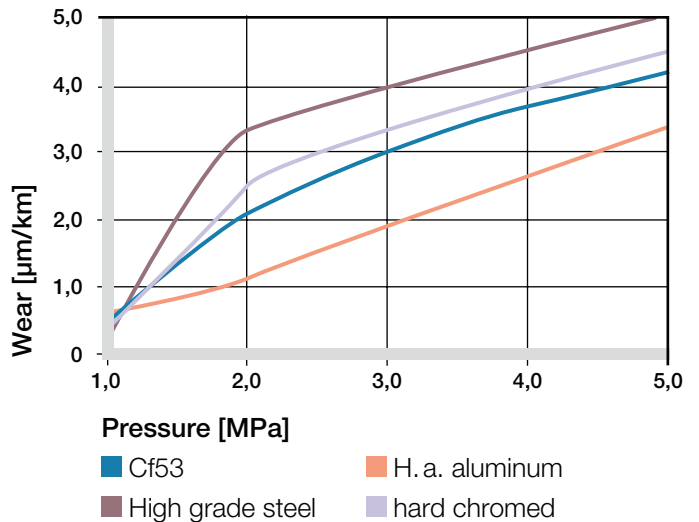

Diagram 07: Wear with different shaft materials in rotational operation, as a function of the pressure

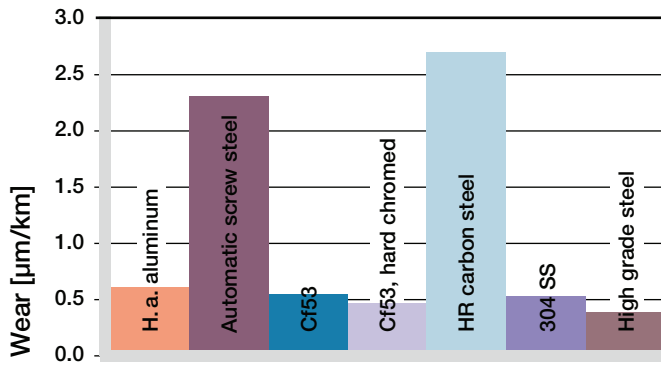

Diagram 08: Wear, rotating with different shaft materials, pressure $p = 1 \text{ MPa}$, $v = 0.3 \text{ m/s}$

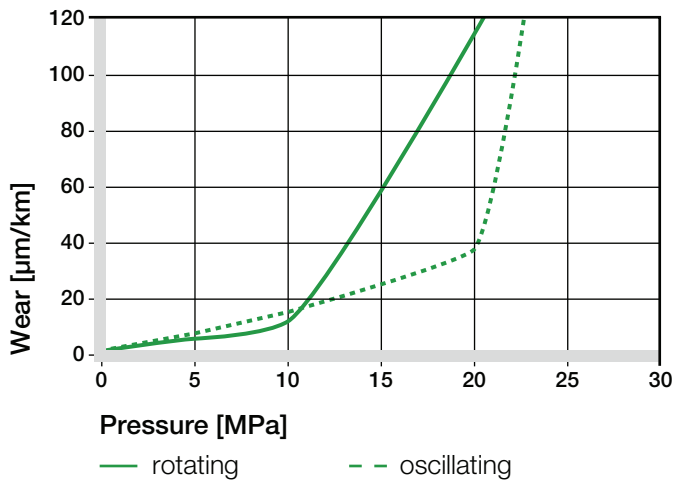

Diagram 09: Wear for oscillating and rotating applications with shaft material Cf53 hardened and ground steel, as a function of the pressure

iglidur® A181	Dry	Greases	Oil	Water
C.o.f. μ	0.10–0.21	0.08	0.03	0.04

Table 04: Coefficient of friction against steel ($R_a = 1 \text{ }\mu\text{m}$, 50 HRC)

Additional Properties

Chemical Resistance

iglidur® A181 bearings can be used under various environmental conditions and in contact with numerous chemicals. Table 05 gives an overview of the chemical resistance of iglidur® A181 bearings at room temperature.

► Chemical Table, page 1258

Medium	Resistance
Alcohol	+
Hydrocarbons	+
Greases, oils without additives	+
Fuels	+
Diluted acids	0 to –
Strong acids	–
Diluted alkalines	+
Strong alkalines	+ to 0

+ resistant **0** conditionally resistant **–** not resistant

All data given at room temperature [$+20 \text{ }^\circ\text{C}$]

Table 05: Chemical resistance

Radiation Resistance

Plain bearings made of iglidur® A181 are resistant to radiation up to an intensity of $2 \cdot 10^2 \text{ Gy}$.

UV Resistance

iglidur® A181 bearings are only conditionally resistant to UV radiation.

Vacuum

When used in a vacuum environment, the iglidur® A181 plain bearings release moisture as a vapour. Therefore, only dehumidified bearings are suitable in a vacuum environment.

Electrical Properties

iglidur® A181 plain bearings are electrically insulating.

Volume resistance $> 10^{12} \text{ }\Omega\text{cm}$

Surface resistance $> 10^{12} \text{ }\Omega$

iglidur® A181 | Technical Data

Moisture Absorption

The moisture absorption of iglidur® A181 plain bearings is approximately 0.2 % in standard atmosphere. The saturation limit submerged in water is 1.3 %. This must be taken into account for these types of applications.

Maximum moisture absorption

At +23 °C/50 % r.h. 0.2 % weight

Max. water absorption 1.3 % weight

Table 06: Moisture absorption

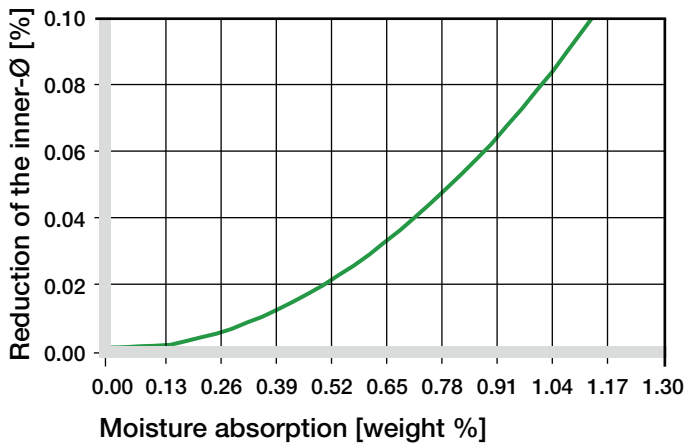

Diagram 10: Effect of moisture absorption on plain bearings

Installation Tolerances

iglidur® A181 plain bearings are standard bearings for shafts with h-tolerance (recommended minimum h9). The bearings are designed for pressfit into a housing machined to a H7 tolerance. After being assembled into a nominal size housing, in standard cases the inner diameter automatically adjusts to the E10 tolerances.

► Testing Methods, page 75

Diameter d1 [mm]	Shaft h9 [mm]	iglidur® A181 E10 [mm]	Housing H7 [mm]
up to 3	0-0.025	+0.014 +0.054	0 +0.010
> 3 to 6	0-0.030	+0.020 +0.068	0 +0.012
> 6 to 10	0-0.036	+0.025 +0.083	0 +0.015
> 10 to 18	0-0.043	+0.032 +0.102	0 +0.018
> 18 to 30	0-0.052	+0.040 +0.124	0 +0.021
> 30 to 50	0-0.062	+0.050 +0.150	0 +0.025
> 50 to 80	0-0.074	+0.060 +0.180	0 +0.030
> 80 to 120	0-0.087	+0.072 +0.212	0 +0.035
> 120 to 180	0-0.100	+0.085 +0.245	0 +0.040

Table 07: Important tolerances for plain bearings according to ISO 3547-1 after pressfit

Sleeve bearing

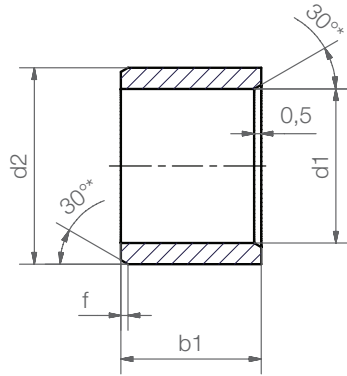

Order key

A181SM-0608-06



- Length b1
- Outer diameter d2
- Inner diameter d1
- Metric
- Type (Form S)
- Material iglidur® A181

Dimensions according to ISO 3547-1 and special dimensions

* thickness < 1 mm, chamfer = 20°

Chamfer in relation to the d1

d1 [mm]:	Ø 1-6	Ø 6-12	Ø 12-30	Ø > 30
f [mm]:	0.3	0.5	0.8	1.2

Dimensions [mm]

Part number		d1	d1-Tolerance*	d2	b1 h13
A181SM-0608-06	New!	6.0	+0.020 +0.068	8.0	6.0
A181SM-0810-10	New!	8.0	+0.025 +0.083	10.0	10.0
A181SM-1012-10	New!	10.0	+0.025 +0.083	12.0	10.0
A181SM-1214-12	New!	12.0	+0.032 +0.102	14.0	12.0
A181SM-1618-15	New!	16.0	+0.032 +0.102	18.0	15.0
A181SM-2023-20	New!	20.0	+0.040 +0.124	23.0	20.0

* after pressfit. Testing methods ► page 75

delivery from stock
time

prices price list online
www.igus.eu/eu/a181

Flange bearing

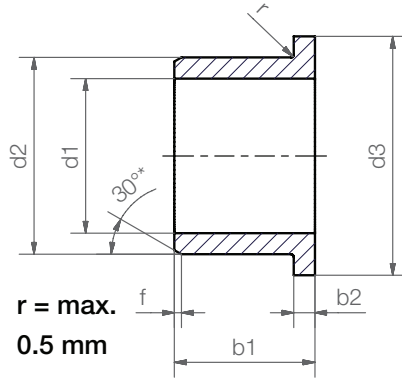

Order key

A181FM-0608-06

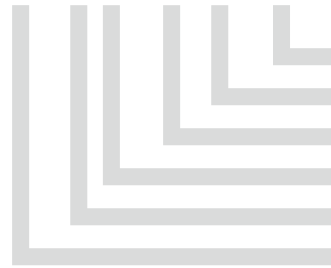

Dimensions according to ISO 3547-1 and special dimensions

* thickness < 1 mm, chamfer = 20°

Chamfer in relation to the d1

d1 [mm]:	Ø 1-6	Ø 6-12	Ø 12-30	Ø > 30
f [mm]:	0.3	0.5	0.8	1.2

Dimensions [mm]

Part number	d1	d1-Tolerance*	d2	d3	b1	b2
				d13	h13	-0.14
A181FM-0608-06 New!	6.0	+0.020 +0.068	8.0	12.0	6.0	1.0
A181FM-0810-10 New!	8.0	+0.025 +0.083	10.0	15.0	10.0	1.0
A181FM-1012-10 New!	10.0	+0.025 +0.083	12.0	18.0	10.0	1.0
A181FM-1214-12 New!	12.0	+0.032 +0.102	14.0	20.0	12.0	1.0
A181FM-1618-17 New!	16.0	+0.032 +0.102	18.0	24.0	17.0	1.0
A181FM-2023-21 New!	20.0	+0.040 +0.124	23.0	30.0	21.5	1.5

* after pressfit. Testing methods ► page 75



Don't find your size?

Do you need another length, other dimensions or tolerances? You need a particular design or alternative for your application? Please call us. igus® listens to your needs and provides you a solution in a very short time.



delivery from stock
time



prices price list online
www.igus.eu/eu/a181