

# SY 40 TF

Material

Cast iron

## Dimensions

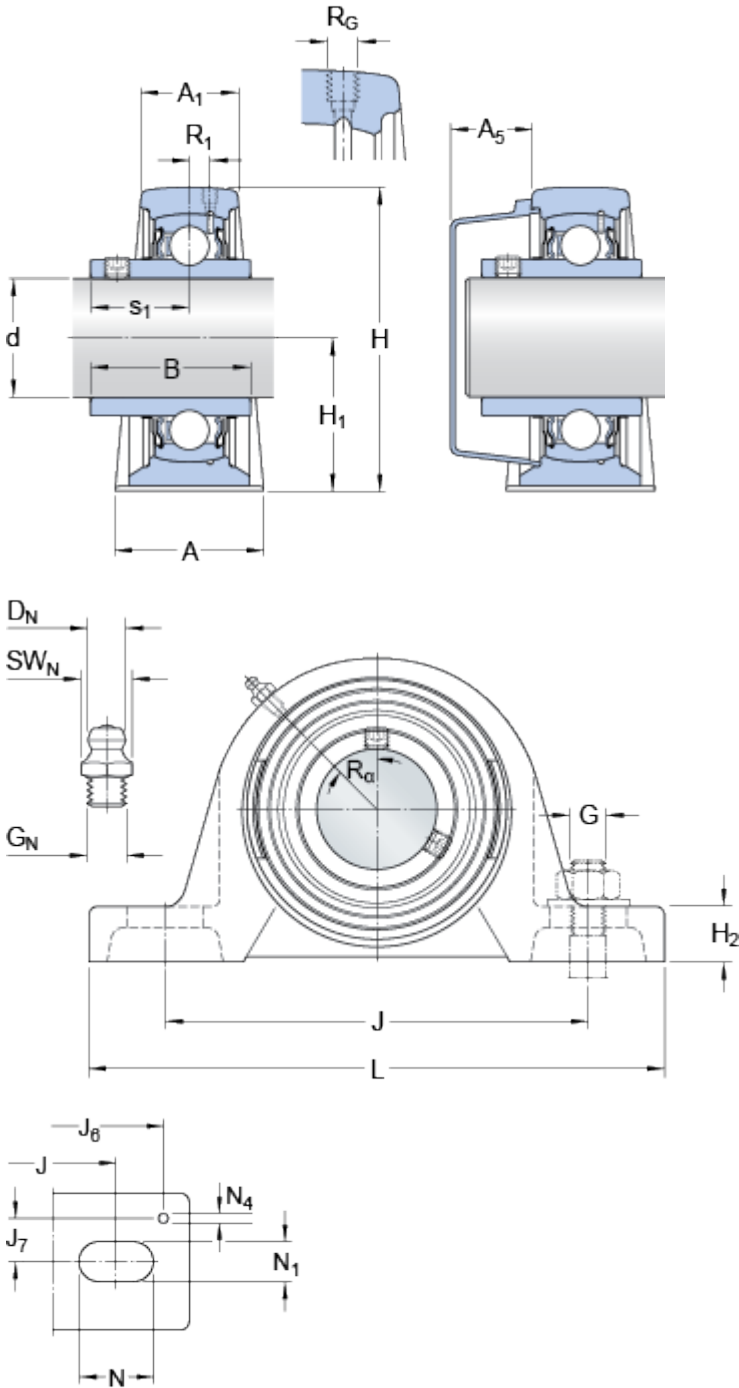

d	40	mm
A	48	mm
A <sub>1</sub>	30	mm
A <sub>5</sub>	23.5	mm
B	49.2	mm
H	99	mm
H <sub>1</sub>	49.2	mm
H <sub>2</sub>	19	mm
J	135.5	mm
J	max. 146	mm
J	min. 125	mm
L	175	mm
N	24.5	mm
N <sub>1</sub>	14	mm
s <sub>1</sub>	30.2	mm

### Threaded hole

R<sub>G</sub> 1 / 4 - 28 UNF

R<sub>1</sub> 3.5 mm

$R_{\alpha}$  45 °

#### Grease fitting

$D_N$  6.5 mm

$SW_N$  7 mm

$G_N$  1 / 4 - 28 SAE-LT

#### Dowel pins

$J_6$  161 mm

$J_7$  17 mm

$N_4$  4 mm

### Calculation data

---

Basic dynamic load rating C 30.7 kN

Basic static load rating  $C_0$  19 kN

Fatigue load limit  $P_u$  0.8 kN

Limiting speed 4800 r/min

(with shaft tolerance h 6 )

### Mass

---

Mass bearing unit 1.75 kg

### Mounting information

---

Hexagonal key size for grub screw N 4 mm

Recommended tightening torque for grub screw 6.5 N·m

Recommended diameter for attachment bolts, mm G 12 mm

Recommended diameter for attachment bolts, inch G 0.5 in

### Appertaining products

---

Housing SY 508 M

Bearing YAR 208-2F

### Appropriate products

---

End cover ECY 208

