

# SY 25 TF

Material

Cast iron

## Dimensions

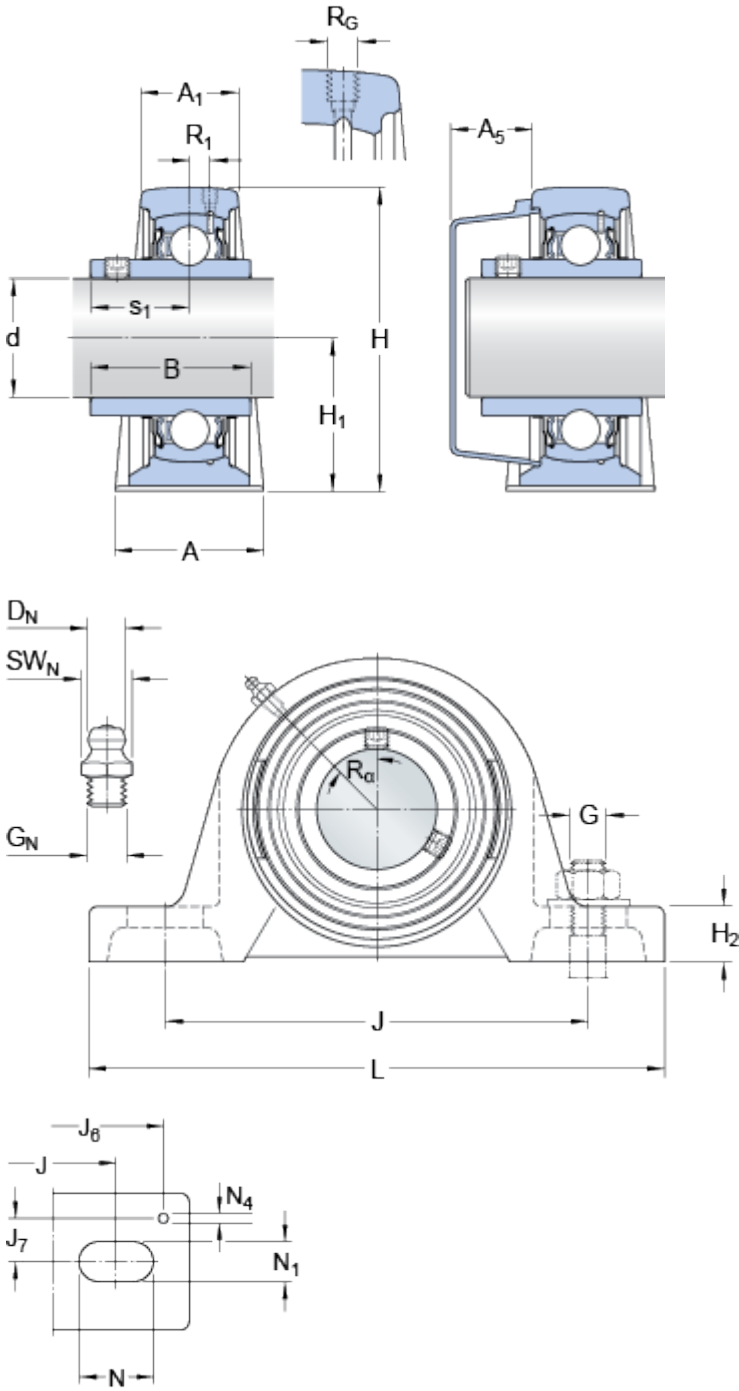

d	25	mm
A	36	mm
A <sub>1</sub>	22	mm
A <sub>5</sub>	18	mm
B	34.1	mm
H	70	mm
H <sub>1</sub>	36.5	mm
H <sub>2</sub>	16	mm
J	102	mm
J	max. 110	mm
J	min. 94	mm
L	130	mm
N	19.5	mm
N <sub>1</sub>	11.5	mm
s <sub>1</sub>	19.8	mm

### Threaded hole

R<sub>G</sub> 1 / 4 - 28 UNF

R<sub>1</sub> 2 mm

$R_{\alpha}$  45 °

#### Grease fitting

$D_N$  6.5 mm

$SW_N$  7 mm

$G_N$  1 / 4 - 28 SAE-LT

#### Dowel pins

$J_6$  120 mm

$J_7$  13 mm

$N_4$  4 mm

### Calculation data

---

Basic dynamic load rating  $C$  14 kN

Basic static load rating  $C_0$  7.8 kN

Fatigue load limit  $P_u$  0.335 kN

Limiting speed 7000 r/min

(with shaft tolerance h 6 )

### Mass

---

Mass bearing unit 0.7 kg

### Mounting information

---

Hexagonal key size for grub screw N 3 mm

Recommended tightening torque for grub screw 4 N·m

Recommended diameter for attachment bolts, mm G 10 mm

Recommended diameter for attachment bolts, inch G 0.375 in

### Appertaining products

---

Housing SY 505 M

Bearing YAR 205-2F

### Appropriate products

---

End cover ECY 205

