

Soft polyurethane wheels

Electro-welded steel bracket for heavy loads

COVERING

Soft mould-on polyurethane, hardness 75 Shore A.

WHEEL CENTRE BODY

Pressure die-cast aluminium.

ROLLING ACTION

Hub with ball bearings. Ideal solution for heavy loads and continuous moving.

FIXED PLATE BRACKET

Electrolytically zinc-plated electro-welded steel. The bracket is designed to withstand loads up to 7000N. Suitable for heavy industrial applications and for severe conditions of use, such as impact and high speeds.

TURNING PLATE BRACKET

Electrolytically zinc-plated electro-welded steel. The presence of an axial bearing and a conical bearing ensures excellent manoeuvrability also at full load and increases the resistance of the bracket against side impact. It is equipped with lubricator and anti-loosening system of the locking nut. The bracket is designed to withstand loads up to 7000N. Suitable for heavy industrial applications and for severe conditions of use, such as impact and high speeds.

It consists of (see fig.1):

1. fitting plate: forged steel with built-in pin, electrolytically zinc-plated;
2. fork: drawn sides electro-welded to the flange, electrolytically zinc-plated;
3. rotation system: axial ball bearing and conical roller bearing;
4. lubricator;
5. anti-loosening system of the locking nut.

BRAKE

Dual-effect rear brake with simultaneous locking of wheel and bracket. The brake is simple and effective to use: it is actuated and released by a simple action from the top downward at the tip of two separate pedals, thus ensuring the utmost manoeuvring comfort. The braking efficacy may be adjusted with a socket head screw M8.

STANDARD EXECUTIONS

- **PSL-WH**: fixed plate bracket, without brake.
- **SSL-WH**: turning plate bracket, without brake.
- **SSF-WH**: turning plate bracket, with brake.

APPLICATIONS

Suitable for heavy industrial applications and severe conditions of use, such as impact and high speeds. The mould-on polyurethane wheel ensures excellent rolling resistance and elasticity, high wear and tearing resistance. For further information see RE.F2 on page 1963.

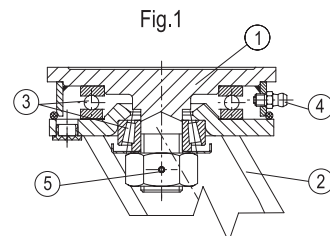

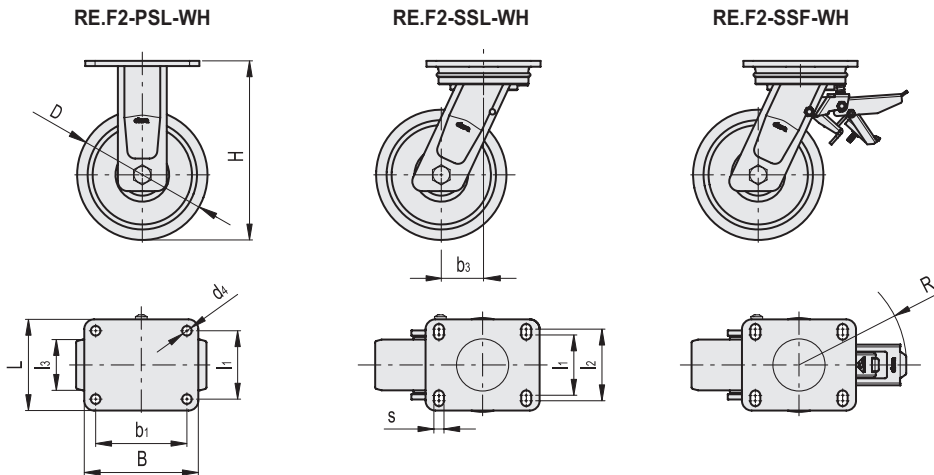

RE.F2-PSL-WH

Code	Description	D	d4	l1	l3	H	B	L	b1	Rolling resistance# [N]	Dynamic carrying capacity# [N]	⚖️
452473	RE.F2-160-PSL-WH	160	11	80	50	215	135	110	105	5500	5500	3260
452474	RE.F2-200-PSL-WH	200	11	80	50	252	135	110	105	7000	7000	3990

RE.F2-SSL-WH

Code	Description	D	l1	l2	l3	H	B	L	s	b1	b3	Rolling resistance# [N]	Dynamic carrying capacity# [N]	⚖️
452433	RE.F2-160-SSL-WH	160	73	87	50	215	135	110	11	105	60	5500	5500	4250
452434	RE.F2-200-SSL-WH	200	73	87	50	252	135	110	11	105	70	7000	7000	4970

RE.F2-SSF-WH

Code	Description	D	l1	l2	l3	H	B	L	s	b1	b3	R	Rolling resistance# [N]	Dynamic carrying capacity# [N]	⚖️
452453	RE.F2-160-SSF-WH	160	73	87	50	215	135	110	11	105	60	157	5500	5500	5130
452454	RE.F2-200-SSF-WH	200	73	87	50	252	135	110	11	105	70	157	7000	7000	6310

For rolling resistance and dynamic carrying capacity see Technical Data on page 2014.