

Soft polyurethane wheels

Steel sheet bracket for medium-heavy loads

COVERING

Soft mould-on polyurethane, hardness 75 Shore A.

WHEEL CENTRE BODY

Pressure die-cast aluminium.

ROLLING ACTION

Hub with ball bearings. Ideal solution for heavy loads and continuous moving.

FIXED PLATE BRACKET

Yellow zinc-plated steel sheet (test in saline fog chamber above 72h). The bracket is designed to withstand loads up to 7000N. It ensures capacities that make it suitable for heavy industrial applications.

TURNING PLATE BRACKET

Yellow zinc-plated steel sheet (test in saline fog chamber above 72h). The bracket is designed to withstand loads up to 7000N. It ensures capacities that make it suitable for heavy industrial applications. It consists of (see Fig.1):

1. fitting plate: yellow zinc-plated steel sheet;
2. fork: yellow zinc-plated steel sheet;
3. ball race ring: yellow zinc-plated steel sheet;
4. central pin: class 8.8 steel screw and steel nut;
5. rotation system: dual grease-lubricated ball race;
6. dust seal: RAL 7015 dark grey technopolymer.

BRAKE

Front brake (RE.F2-100) or rear brake (RE.F2-125-160-200) dual-effect with simultaneous locking of wheel and bracket.

The brake is simple and effective to use: it is actuated and released by a simple action from the top downward at the tip of two separate pedals, thus ensuring the utmost manoeuvring comfort.

The braking efficacy may be adjusted with a socket head screw M8.

STANDARD EXECUTIONS

- **PSL-H**: fixed bracket, without brake.
- **SSL-H**: turning plate bracket, without brake.
- **SSF-H**: turning plate bracket, with brake.

APPLICATIONS

Excellent smoothness and elasticity features, high wear and tearing resistance.

For further information see RE.F2 on page 1963.

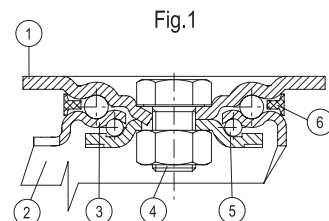
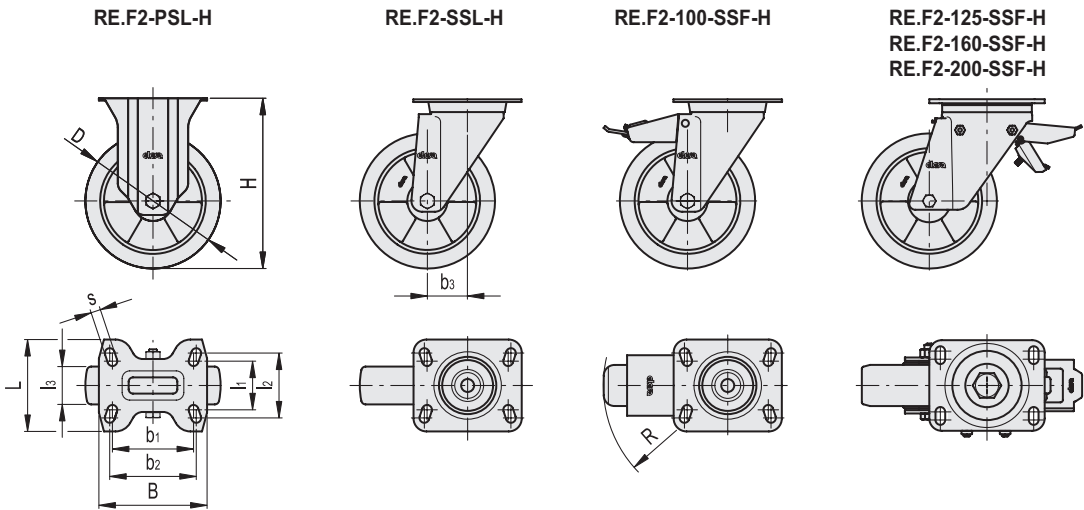

Fig.1



RE.F2-PSL-H

Code	Description	D	l1	l2	l3	H	B	L	s	b1	b2	Rolling resistance# [N]	Dynamic carrying capacity# [N]	⚖️
452461	RE.F2-100-PSL-H	100	45	60	40	138	100	85	9	75	80	3000	3000	850
452462	RE.F2-125-PSL-H	125	73	87	40	170	140	110	11	105	105	3500	3500	1690
452463	RE.F2-160-PSL-H	160	73	87	50	205	140	110	11	105	105	5500	5500	2110
452464	RE.F2-200-PSL-H	200	73	87	50	250	140	110	11	105	105	7000	7000	2850

RE.F2-SSL-H

Code	Description	D	l1	l2	l3	H	B	L	s	b1	b2	b3	Rolling resistance# [N]	Dynamic carrying capacity# [N]	⚖️
452421	RE.F2-100-SSL-H	100	45	60	40	138	100	85	9	75	80	46	3000	3000	1350
452422	RE.F2-125-SSL-H	125	73	87	40	170	140	110	11	105	105	70	3500	3500	2330
452423	RE.F2-160-SSL-H	160	73	87	50	205	140	110	11	105	105	70	5500	5500	2600
452424	RE.F2-200-SSL-H	200	73	87	50	250	140	110	11	105	105	70	7000	7000	4310

RE.F2-SSF-H

Code	Description	D	l1	l2	l3	H	B	L	s	b1	b2	b3	R	Rolling resistance# [N]	Dynamic carrying capacity# [N]	⚖️
452441	RE.F2-100-SSF-H	100	45	60	40	138	100	85	9	75	80	46	123	3000	3000	1520
452442	RE.F2-125-SSF-H	125	73	87	40	170	140	110	11	105	105	70	126	3500	3500	2860
452443	RE.F2-160-SSF-H	160	73	87	50	205	140	110	11	105	105	70	126	5500	5500	4170
452444	RE.F2-200-SSF-H	200	73	87	50	250	140	110	11	105	105	70	126	7000	7000	4910

For rolling resistance and dynamic carrying capacity see Technical Data on page 2014.