

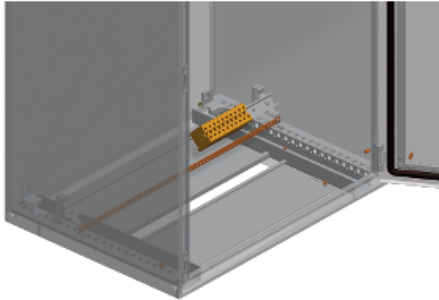

Price\* : 8.47 GBP



## Main

Range	Spacial
Application	Multi-purpose
Product or component type	Support bracket
Mounting location	On mounting plate On structure of enclosure
Mounting support	DIN rail Earthing bar
Device composition	Fixing elements 1 combined support brackets
Quantity per set	Set of 10

## Complementary

Material	Zinc coated steel
Height	86.5 mm
Width	20 mm
Depth	115 mm

## Offer Sustainability

Sustainable offer status	Green Premium product
RoHS (date code: YYWW)	Compliant - since 0940 - Schneider Electric declaration of conformity <a href="#">Schneider Electric declaration of conformity</a>
REACH	Reference not containing SVHC above the threshold <a href="#">Reference not containing SVHC above the threshold</a>
Product environmental profile	Available <a href="#">Product Environmental Profile</a>
Product end of life instructions	Need no specific recycling operations

Contractual warranty

---

Warranty period	18 months	18 months
-----------------	-----------	-----------

---