

SYR-380Q

(RoHS)

DATE:2006.12.25

1 . Electrical Characteristics

VER.:1

Oscillation Frequency (KHz)	1.5 ~ 3.5
Operating Voltage (Vdc)	5 ~ 15
Rated Voltage (Vdc)	12
Current Consumption (mA/max.)	600 at Rated Voltage
Sound Pressure Level (dB/min.)	110 at 100cm at Rated Voltage
Tone/Pulse Rate (Hz)	Sweep 3.3 ±20%
Operating Temperature (°C)	-20 ~ +70
Storage Temperature (°C)	-30 ~ +80
Manual soldering conditionsn (°C)	350±20°C / within 5sec

2 . Dimensions and Material

2-1 Shape

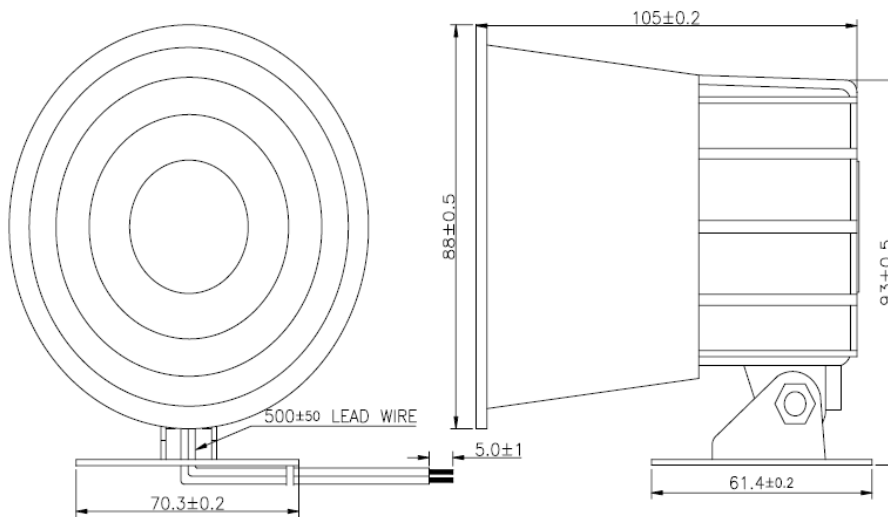

Unit : mm

2-2 Material

Housing	ABS 757 UL94HB plastic resin (Color : Black)
Leading Wire	20 AWG
Weight (Gram)	361.6

3. TESTING METHOD

• Standard Measurement conditions

Temperature: $25 \pm 2^\circ\text{C}$ Humidity: 45-60%

• Acoustic Characteristics

The oscillation frequency, current consumption and sound pressure are measured by the measuring instruments shown below.

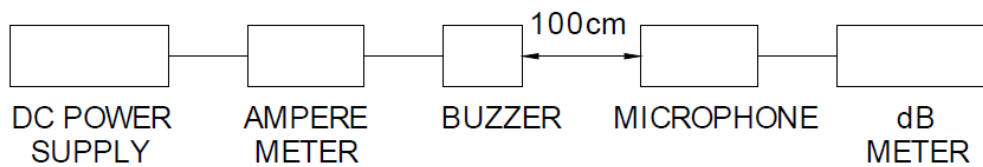

In the measuring test, buzzer is placed as follows:

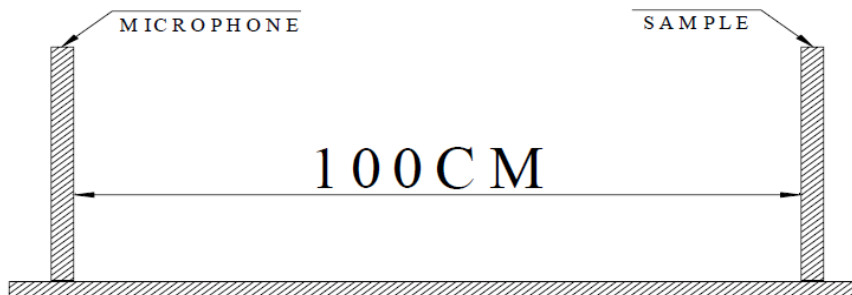

4. RELIABILITY

ITEMS	METHOD OF TEST AND MEASUREMENTS	PERFORMANCE
<i>Coldness withstanding</i>	<i>After 98 hours of being exposed to -30 °C environment, should be returned to normal environment for 2 hours, then re-proceed to test.</i>	<i>No abnormality shall exist</i>
<i>Hotness withstanding</i>	<i>After 98 hours of being exposed to +80 °C environment, should be returned to normal environment for 2 hours, then re-proceed to test.</i>	<i>No abnormality shall exist</i>
<i>Humidity withstanding</i>	<i>After 98 hours of being exposed to 40 °C 95%RH environment in actual operation, should be returned to normal environment for 2 hours, then re-proceed to test.</i>	<i>No abnormality shall exist</i>
<i>Vibration withstanding</i>	<i>Linear vibrate frequency rate: 5~55Hz Time:180sec , applied in X, Y and Z directions for 3 times each.</i>	<i>No abnormality shall exist</i>