

# CLW-1809-W2E-2555-ER

## series



### ■ Features:

- Universal AC input / Full range
- ErP step II / CEC level VI compliance
- No load power consumption  $P < 0.075W$
- Protections: Overload / Short circuit / Over Voltage

## ELECTRICAL SPECIFICATION



MODEL	CLW 1809 W2E 2555 ER
-------	----------------------

### OUTPUT

Rated Voltage	9V
Rated Current	2A
Current Range	0 ÷ 2A
Rated Power	18W
Line Regulation	± 1%
Load Regulation	± 5%
Tolerance [3]	± 8%
Ripple & Noise (max.) [2]	200mV <sub>P-P</sub>
Setup, Rise Time [4]	5000ms, 30ms / 230VAC at full load
Hold up Time (typ.)	4ms / 230VAC at full load

### INPUT

Voltage Range	90 ÷ 264VAC
Frequency Range	47 ÷ 63Hz
Efficiency (typ.)	81.6%
AC Current (typ.)	0.4A / 115VAC, 0.2A / 230VAC
No load Power Consumption (max.)	0.075W

### PROTECTIONS

Overload	Range: 105-200% Auto-recovery.
Short Circuit	Type: hiccup mode, auto-recovery.
Over Voltage	Type: auto-recovery.

# CLW-1809-W2E-2555-ER

## series



### WORKING ENVIRONMENT

<b>Working Temperature</b>	0°C ÷ 40°C
<b>Working Humidity</b>	10 ÷ 90% RH non-condensing
<b>Storage Temperature and Humidity</b>	-20°C ÷ 85°C, 5 ÷ 90% RH non-condensing

### SAFETY and EMC REGULATIONS

<b>Safety Standards</b>	Compliance to EN 60950-1
<b>Withstand Voltage</b>	IN/OUT: 3.6kVAC
<b>Isolation Resistance</b>	IN/OUT: 50MΩ/500VDC/25°C/70%
<b>EMC Emission</b>	Compliance to EN55032
<b>EMC Immunity</b>	Compliance to EN61000-4-2, -3, -4, -5
<b>Harmonic Current</b>	Compliance to EN61000-3-3; EN61000-3-2

### OTHERS

<b>DC wire and plug</b>	Wire: 22AWG*2C, length = 1500mm	Plug: <b>2.5/5.5</b> , positive inside
<b>Dimensions</b>	78.7 x 27.6 x 69.1mm (L x W x H)	
<b>Net Weight</b>	90.1g	

1. All parameters NOT specially mentioned are measured at 230VAC input, rated load and 25°C of ambient temperature.
2. Ripple & noise are measured at 20MHz of bandwidth by using a 12" twisted pair-wire terminated with a 0.1μF i 47μF parallel capacitor.
3. Tolerance includes set up tolerance, line regulation and load regulation.
4. Setup and rise time is measured from 0 to 90% rated output voltage.
5. Power supply is considered as component not indented to apply by end-user. Power supply meets safety and EMC standards however the final equipment with power supply must be re-quality to comply with EMC Directives.

### MECHANICAL SPECIFICATION

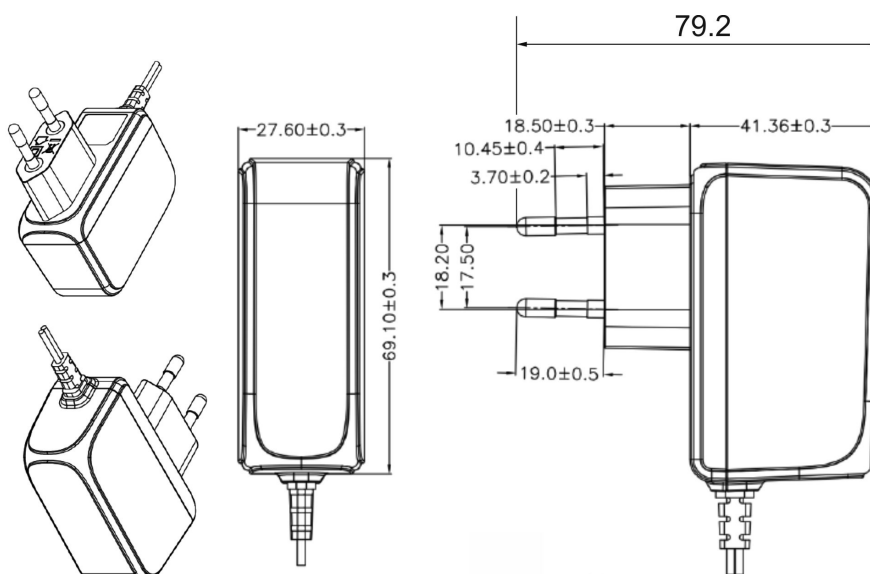

# CLW-1809-W2E-2555-ER

series

