

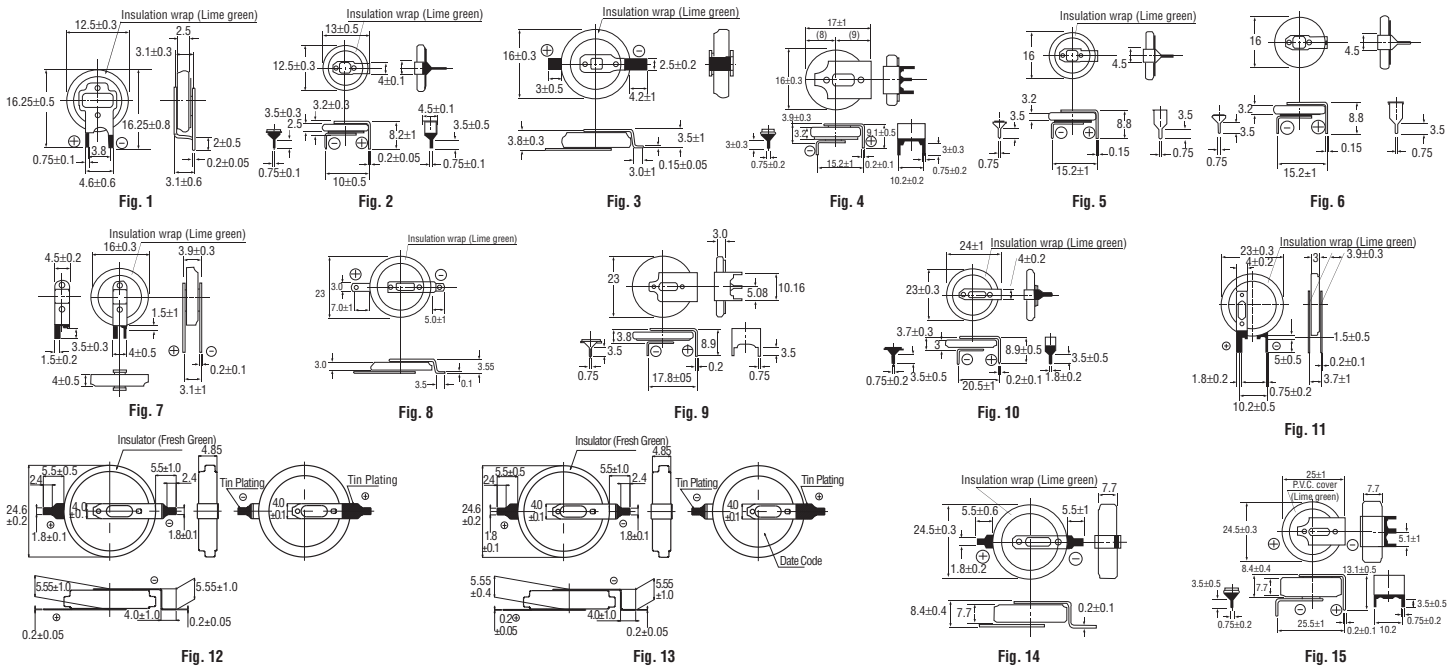

Coin Type Lithium Batteries with Tabs PCB Terminal High-Temp. Coin Type



Temperature Range: -40°C to 125°C.

Stock No.	Mfr.'s Type	Fig.	Voltage (V)	Capacity (mAh)	Drain (mA)	Dia. (mm)	Height (mm)	EACH				
								1-4	5-9	10-24	25-49	50-99
70196958	BR1225A/FAN	1	3	48	0.03	12	2.5	2.26	2.11	2.01	1.92	1.85
70196959	BR1225A/HBN	2	3	48	0.03	12	2.5	2.27	2.11	2.01	1.92	1.85
70196960	BR1632A/FAN	3	3	120	0.03	16	3.2	2.08	1.94	1.84	1.76	1.70
70196961	BR1632A/GAN	4	3	120	0.03	16	3.2	2.08	1.94	1.84	1.76	1.70
70196962	BR1632A/HAN	5	3	120	0.03	16	3.2	2.08	1.94	1.84	1.76	1.70
70196963	BR1632A/HBN	6	3	120	0.03	16	3.2	2.08	1.92	1.83	1.74	1.68
70196964	BR1632A/VAN	7	3	120	0.03	16	3.0	2.06	1.94	1.84	1.76	1.70
70196965	BR2330A/FAN	8	3	255	0.03	23	3.0	2.46	2.29	2.18	2.08	2.00
70196966	BR2330A/GAN	9	3	255	0.03	23	3.0	2.45	2.29	2.18	2.08	2.00
70196967	BR2330A/HDN	10	3	255	0.03	23	3.0	2.45	2.29	2.18	2.08	2.00
70196968	BR2330A/VAN	11	3	255	0.03	23	3.0	2.45	2.29	2.18	2.08	2.00
70233945	BR2450A/FAN	12	3	620	0.03	24	5.0	4.74	4.55	4.29	4.13	3.99
70233946	BR2450A/FBN	12	3	620	0.03	24	5.0	4.74	4.55	4.29	4.13	3.99
70233947	BR2450A/HAN	13	3	620	0.03	24	5.0	4.74	4.55	4.29	4.13	3.99
70196969	BR2477A/FBN	14	3	1000	0.03	24	7.7	3.98	3.72	3.54	3.37	3.24
70196970	BR2477A/GAN	15	3	1000	0.03	24	7.7	3.98	3.72	3.54	3.37	3.24
70196971	BR2477A/HBN	16	3	1000	0.03	24	7.7	3.98	3.72	3.54	3.37	3.24
70196972	BR2477A/VAN	17	3	1000	0.03	24	7.7	3.98	3.72	3.54	3.37	3.24

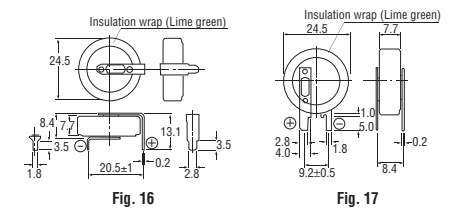

Vanadium Pentoxide Lithium Rechargeable Batteries

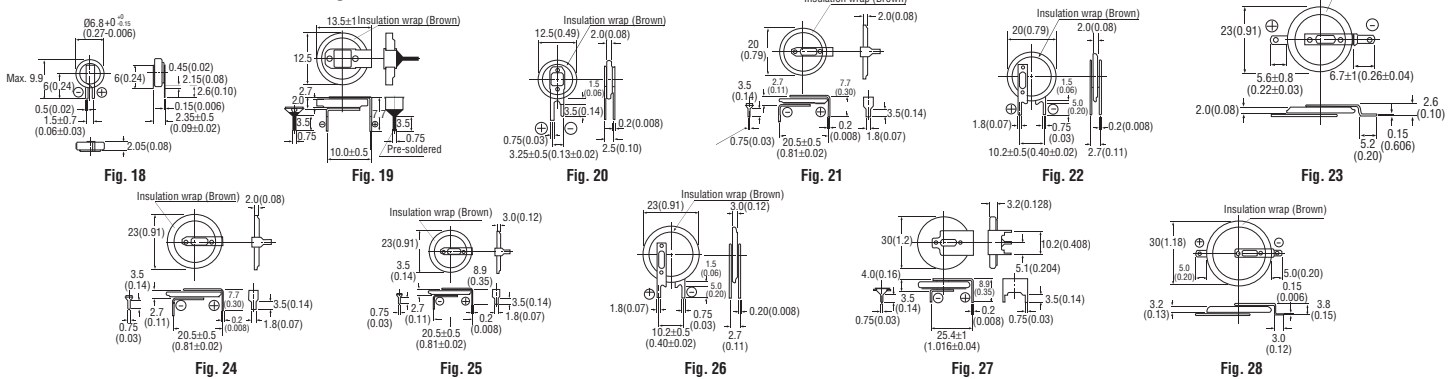

Stock No.	Mfr.'s Type	Fig.	Voltage (V)	Capacity (mAh)	Standard Drain (mA)	Charge Current (mA)	Dia. (mm)	Height (mm)	EACH				
									1-4	5-9	10-24	25-49	50-99
70196947	VL621DN	18	3	1.5	0.01	<0.2	6.8	2.05	4.94	4.61	4.38	4.17	4.02
70196948	VL1220-HFN	19	3	7.0	0.03	<0.5	12.5	2.00	4.94	4.60	4.37	4.17	4.02
70196949	VL1220-VCN	20	3	7.0	0.03	<0.5	12.5	2.00	4.94	4.61	4.37	4.17	4.02
70196950	VL2020-HFN	21	3	20.0	0.07	<1.5	20.0	2.00	5.19	4.84	4.61	4.39	4.22
70196951	VL2020-VCN	22	3	20.0	0.07	<1.5	20.0	2.00	5.24	4.89	4.65	4.43	4.27
70196952	VL2320-F2N	23	3	30.0	0.10	<2.0	23.0	2.00	6.39	5.96	5.68	5.41	5.21
70196953	VL2320-HFN	24	3	30.0	0.10	<2.0	23.0	2.00	6.45	6.02	5.73	5.46	5.26
70196954	VL2330-HFN	25	3	50.0	0.10	<2.0	23.0	3.00	8.18	7.63	7.25	6.92	6.67
70196955	VL2330-VCN	26	3	50.0	0.10	<2.0	23.0	3.00	8.18	7.63	7.25	6.92	6.67
70196956	VL3032-GUFN	27	3	100.0	0.20	<4.0	30.0	3.20	9.89	9.22	8.78	8.37	8.06
70196957	VL3032-F2N	28	3	100.0	0.20	<4.0	30.0	3.20	13.25	12.34	11.75	11.21	10.80