

INDUSTRIAL
BY DURACELL®

ID1203
Size: 4.5V (3LR12)
Alkaline-Manganese Dioxide Battery

Zn/MnO₂

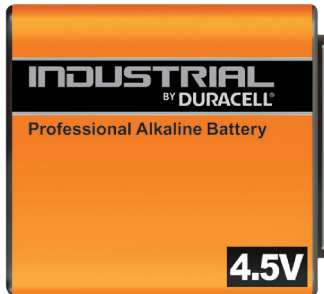

Nominal voltage	4.5V
Impedance	810 m-ohm @ 1 kHz
Typical weight	154 g (5.4 oz)
Typical volume	83 cm ³ (5.1 in ³)
Terminals	Flat
Storage temperature range	-20°C to 35°C (-4°F to 95°F)
Operating temperature range	-20°C to 54°C (-4°F to 130°F)
Designation	IEC: 3LR12

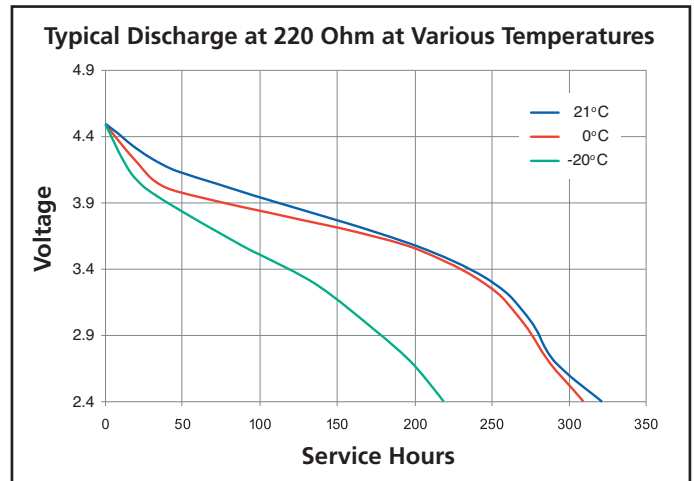
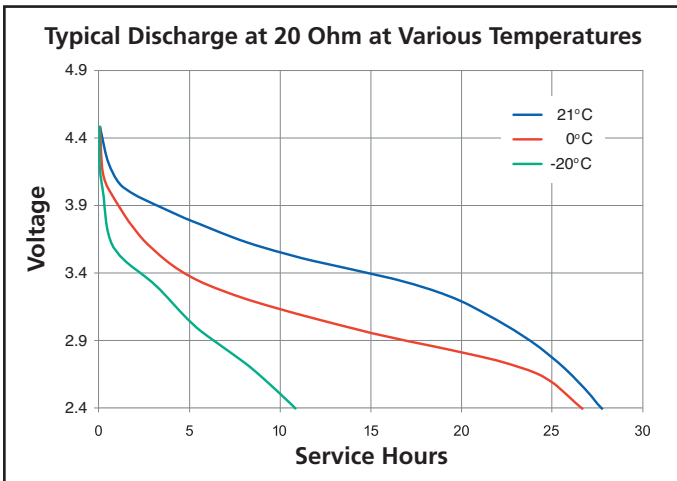
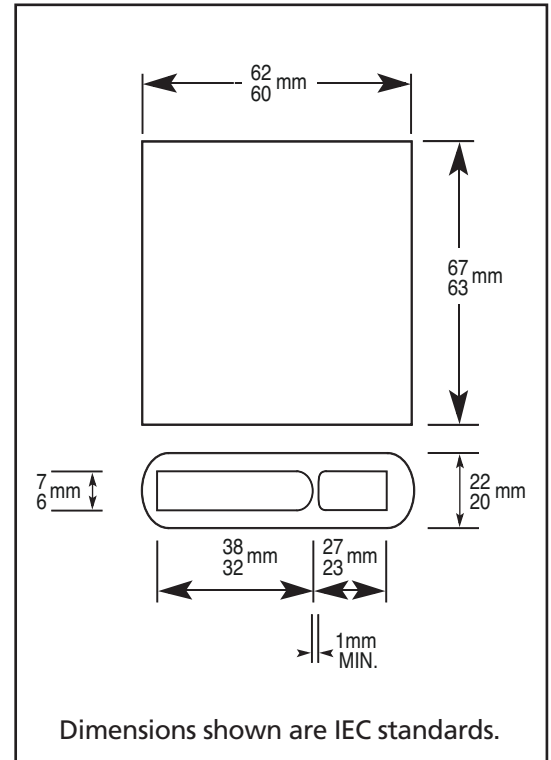

DURACELL
BATTERIES

Berkshire Corporate Park
Bethel, CT. 06801 U.S.A.
Telephone: Toll-free 1-800-544-5454
www.duracell.com

Delivered capacity is dependent on the applied load, operating temperature and cut-off voltage. Please refer to the charts and discharge data shown for examples of the energy/service life that the battery will provide for various load conditions.