

ELECTRONIC BISTABLE PULSE RELAY
 group type

BIS-412i
 230V

WARRANTY. The F&F products are covered by a warranty of the 24 months from the date of purchase. Effective only with proof of purchase. Contact your dealer or directly with us. More information how to make a complaint can be found on the website:
www.fif.com.pl/reklamacje



Do not dispose of this device in the trash along with other waste! According to the Law on Waste, electro coming from households free of charge and can give any amount to up to that end point of collection, as well as to store the occasion of the purchase of new equipment (in accordance with the principle of old-for-new, regardless of brand). Electro thrown in the trash or abandoned in nature, pose a threat to the environment and human health.



Purpose

BIS-412 electronic bistable pulse relay is designed to work in a group system. Single relay allows you to switch the controlled receiver on and off after each current pulse triggered by pressing a momentary (bell) button of a local control that is connected to that relay. The group system allows you to switch on and off all receivers connected to each relay using the buttons of the local control.

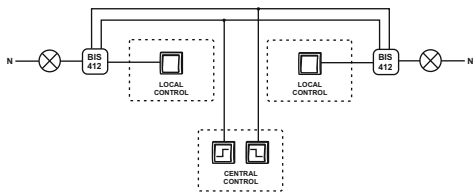

- 1 -

IN/OUT description

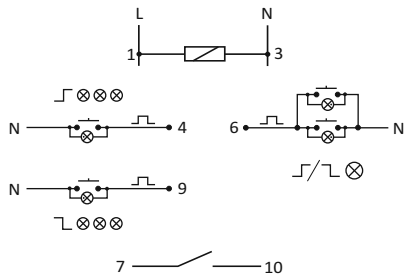

- 1 - 3 power supply 230V (L - N)
- 6 local control - SWITCH ON / SWITCH OFF
- 4 central control - SWITCH ON ALL
- 9 central control - SWITCH OFF ALL
- 7-10 separated contact - 1xNO



With the DC supply voltage, control inputs can be powered only by the (N) neutral wire.

- 3 -

Functioning

The relay power supply is indicated by a green LED.

Local control

Receiver switching on - indicated by a red LED - occurs after current pulse triggered by pressing any momentary button from the local control group. J/L . Next pulse will switch the relay off.

Central control

SWITCH OFF ALL - after current pulse triggered by pressing a momentary button L all receivers that are individually controlled by a particular relay will be switched off (regardless of their status - on or off).

SWITCH ON ALL - after current pulse triggered by pressing a momentary button J all receivers that are individually controlled by a particular relay will be switched on (regardless of their status - on or off).

Relay version "i" is to pin adapted to cooperate with the receivers with high starting current, such as LED fluorescent lamps, ESL fluorescent lamps, electronic transformers, discharge lamps, etc.

Note!

BIS-412i 230V compatible with bell pushes equipped with fluorescent lamps. ($I_i < 5\text{mA}$).



- 2 -

Connection diagram

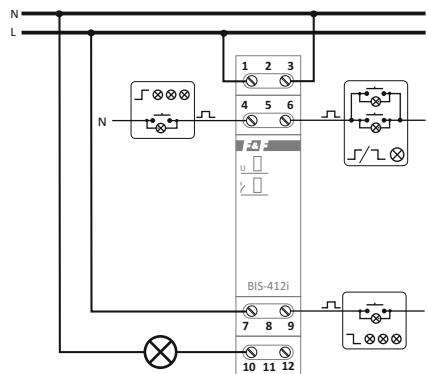
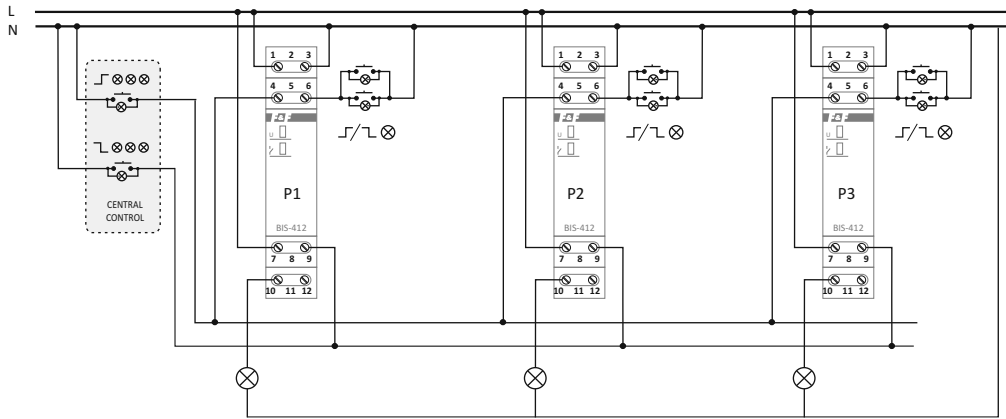

Table of power

incandescent	halogen	fluorescent	energy-saving	LED
2000W	1250W	1000W	500W	250W

The above data are indicative and will heavily depend on the design of a specific receiver (that is especially important for LED bulbs, energy-saving lamps, electronic transformers and pulse power supply units), switching frequency and operating conditions. For more information visit: www.fif.com.pl.

- 4 -



Group scheme

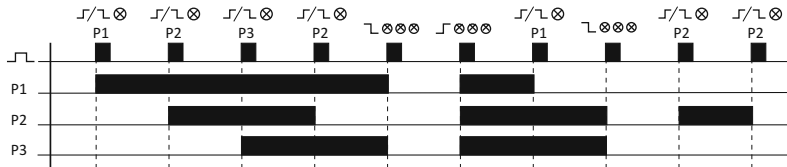

Diagram

- 5 -

- 6 -

Assembly

1. Turn OFF the power.
2. Put on the relay on the rail in the switchgear box.



Do not install a device, that is damaged or incomplete.

3. Connect the power cable to contact 1-3 with marks.



Group of relays working with a common central control must be powered by the same line, e.g. L1 only .



Exercise extreme caution when installing the controller. Improper connection may damage the controller or connected devices.

4. Connect both local and central control switches accordingly to the terminals of the relay in accordance with the function and to the common N wire.



Connecting various N line to the control inputs of the relays may cause improper operation of the system and lead to the destruction of the controllers.

5. Connect in series the contact of the relay into the power supply circuit of the controlled receiver (lighting). Connect power supply to terminal 7; controlled receiver power between contact 10 and N wire.
6. Turn on the power supply.

Technical data

power supply	100±265V AC
contact	separated 1×NO
current load (AC-1)	<16A (160A/20ms)
control pulse	180±265 V AC <20mA
max current control buttons	Σ5mA
activation delay	0.1±0.2sec
power indication	green LED
signalling activation	red LED
power consumption	
standby	0.15W
on	0.6W
working temperature	-25±50°C
terminal	2.5mm ² screw terminals
tightening torque	0.4Nm
dimensions	1 module (18mm)
mounting	on TH-35 rail
ingress protection	IP20

- 7 -

D150203

- 8 -