

1 2 3 4 5 6

A

B

C

D

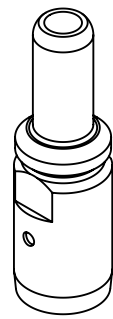
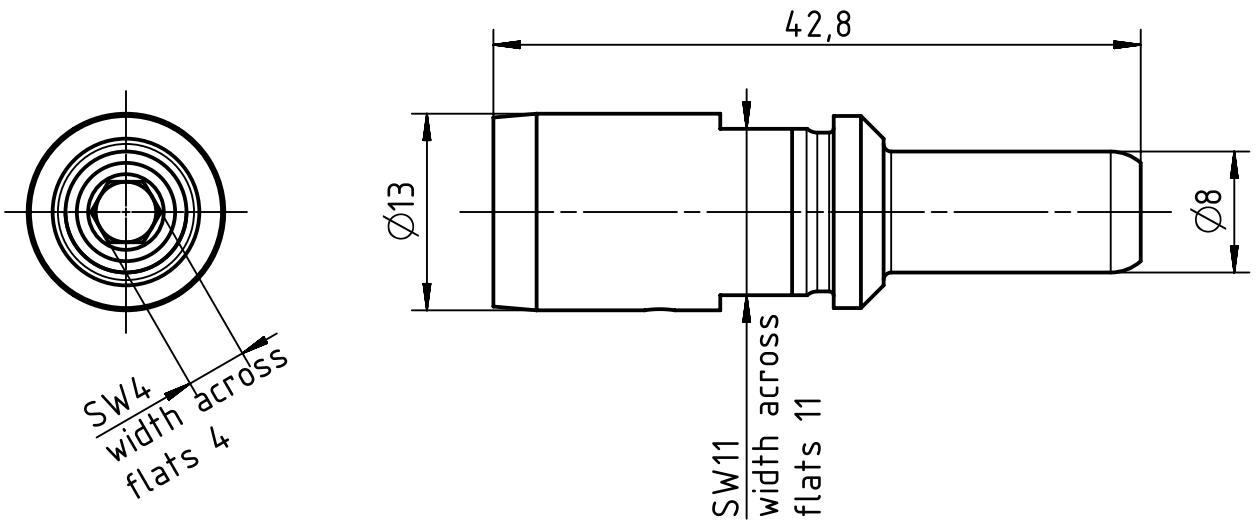

stripping length: 13mm
 tightening torque: 10mm² 16mm² 25mm²
 6Nm 6Nm 7Nm
 for stranded wire 10-25mm², AWG 6-4, fine wire

	All Dimensions in mm Original Size DIN A4	Scale 2:1	Free size tol.		Ref. Sub. TB 09 11 000 6112 v. 21.02.11	
	All rights reserved Department EL PD - DE	Created by SPREENB	Inspected by RUETERA	Standardisation TIEMANNA	Date 2014-03-19	State Final Release
HARTING Electric GmbH & Co. KG D-32339 Espelkamp		Title 100A AXIAL SCREW CONTACT, MALE 10-25mm ²			Doc-Key / ECM-Nr. 100197039/UGD/005/A 500000072810	
		Type TB	Number 09 11 000 6112		Rev. A	Page 1/1