

IEC Appliance Inlet C20, Screw-on Mounting, Rear Side, PCB Terminal

V-Lock



C20



70 °C

**Description**

- Panel Mount:
- Screw-on mounting, from rear-side
- Appliance Inlet, Pin temperature 70 °C, Protection class I
- For PCB mounting

Approvals

- UL File Number: E96454
- CSA File Number: 27324

Newly available variants corresponding to V-Lock mating cordset. The connector is equipped with a notch intended for use with the latching cordset. The cord latching system prevents against accidental removal of the cordset.

References**Weblinks**

[pdf](#), [html](#), [General Product Information](#), [Approvals](#), [RoHS](#), [CHINA-RoHS](#), [Mating Connectors](#), [e-Store](#), [SCHURTER-Stock-Check](#), [Distributor-Stock-Check](#), [Accessories](#)

Technical Data

Ratings IEC	16 A / 250 VAC; 50 Hz
Ratings UL/CSA	21 A / 250 VAC; 60 Hz
Dielectric Strength	> 3 kVAC between L-N > 1.5 kVAC between L/N-PE (1 min/50 Hz)
Allowable Operation Temp.	-25 °C to 70 °C
Degree of Protection	from front side IP 20 acc. to IEC 60529
Protection Class	Suitable for appliances with protection class 1 acc. to IEC 61140
Terminal	For PCB mounting Solder terminal straight

Appliance Inlet	C20 acc. to IEC/EN 60320-1 UL 498, CSA C22.2 no. 42 (for cold conditions) pin-temperature 70 °C, 16 A, Protection Class 1
-----------------	--

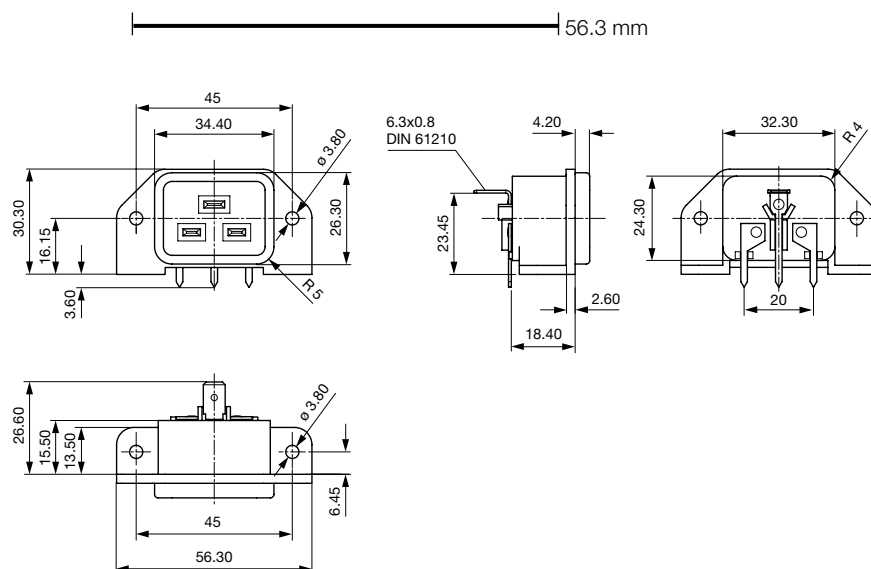
Dimensions

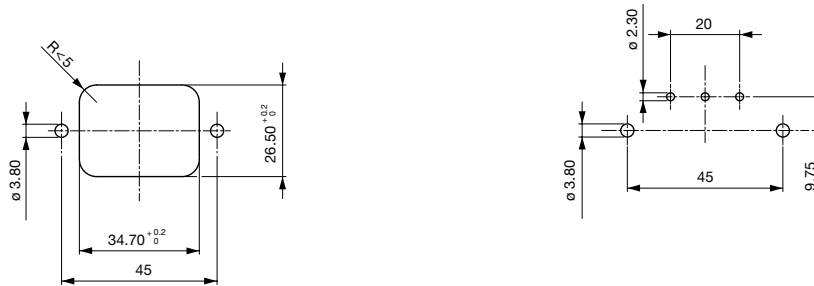

Panel cut-out and Drilling diagram

Config. Code

1601 - H - A B C 0 - D - E I

The characters are placeholders for the correspondingly keys of selections from the key tables.

1601 - **H** - A B C 0 - D - E I = Type

Type	Configuration key
protection class 1	X

1601 - H - **A** B C 0 - D - E I = Terminals

Terminal L	Configuration key
PCB-terminal (standard) 	4

1601 - H - A **B** C 0 - D - E I = Terminals

Terminal N	Configuration key
PCB-terminal (standard)	4

Symbols similar as in table A

1601 - H - A B **C** 0 - D - E I = Terminals

Terminal Ground	Configuration key
PCB-terminal (long)	6

Symbols similar as in table A

1601 - H - A B C 0 - **D** - E I = Color

Color	Configuration key
jet black; RAL9005	A
silver grey; RAL7001	B
pure white; RAL9010	D

1601 - H - A B C 0 - D - **E** I = Style

Style	Configuration key
flange with through holes	2
flange with through holes (special type)	7

1601 - H - A B C 0 - D - E **I** = Additional Terminals

Additional Terminals	Configuration key
without terminal	0
Blade terminal (6.3 x 0.8 mm)	9

Variants

Config. Code	Description	Order Number
1601-X-4460-A-29	1601, IEC Appliance Inlet C20, 70°C1, L: PCB-terminal (standard), N: PCB-terminal (standard), ground: PCB-terminal (long), color: jet black; RAL9005, design: flange with through holes, additional terminal L: Blade terminal (6.3 x 0.8 mm)	6163.0018
1601-X-4460-A-20	1601, IEC Appliance Inlet C20, 70°C1, L: PCB-terminal (standard), N: PCB-terminal (standard), ground: PCB-terminal (long), color: jet black; RAL9005, design: flange with through holes, additional terminal L: without terminal	6163.0019

The listed variants should be available from stock. Other versions on request www.schurter.com/contact

Packaging unit 50 Pcs

Mating Outlets/Connectors

Category / Description

[Connector Overview complete](#)



IEC Connector C19, Rewireable, Straight	0104
IEC Connector C19, Rewireable, Angled	1651
IEC Connector C19, Rewireable, Straight	1652
IEC Connector C19, Rewireable, Angled	4790
IEC Connector C19, Rewireable, Straight	4795

[Connector further types to 1601](#)



[Power Cord Overview complete](#)

Power Cord with IEC Connector C19, Straight	1654
---	------

[Power Cord further types to 1601](#)

[Power Supply or Interconnection Cord Overview complete](#)

Divers Power Supply and Interconnection Cords 16 A	6003.0395
Divers Power Supply and Interconnection Cords 16 A	6009.5195

[Power Supply or Interconnection Cord further types to 1601](#)