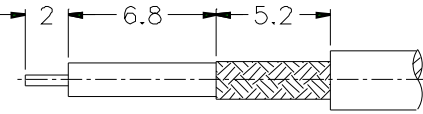
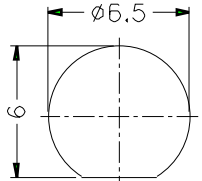
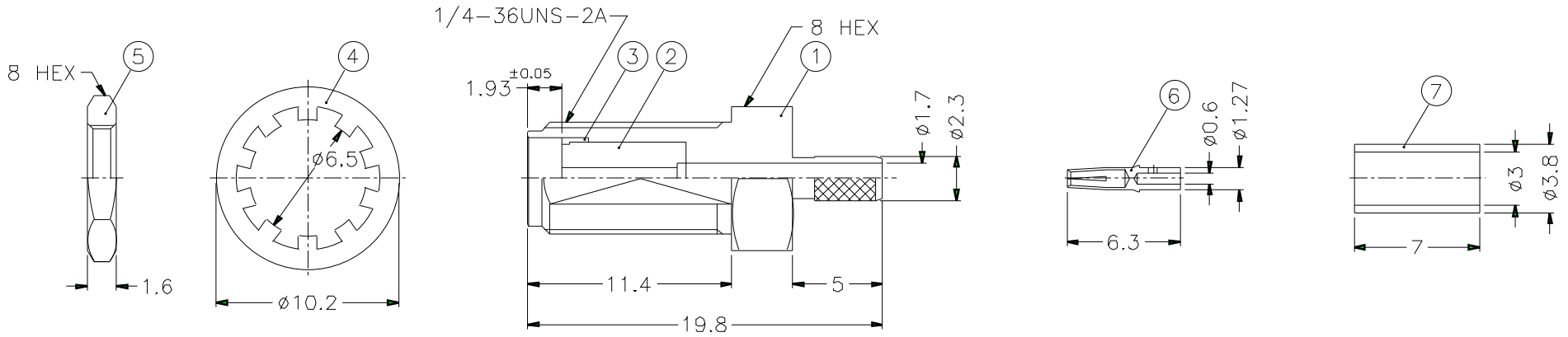

		1		2		3		4		5		6		7		8	
		REVISIONS															
ISS	ZONE	DESCRIPTION\PER REQUEST\DATE															
		 <p>RECOMMENDED CABLE STRIPPING DIM'S</p>  <p>RECOMMENDED MOUNTING HOLE</p>  <p>1/4-36UNS-2A 8 HEX</p> <p>1.93 ±0.05 11.4 19.8 5 1.7 2.3 6.3 7 3 3.8 1.6 10.2 6.5 0.6 1.27 4.6 15</p> <p>NOTES: FINISH (PLATING THICKNESS IN MICRO-INCHES) 1. BRASS PER QQ-B-626 2. BRASS PER QQ-B-613 3. GOLD PL. 3 MIN. THICK OVER NICKEL PL. 100 MIN. THICK OVER COPPER STRIKE 4. BERYLLIUM COPPER PER QQ-C-530 5. GOLD PL. 50 MIN. THICK OVER NICKEL PL. 100 MIN. THICK OVER COPPER STRIKE 6. TEFLON MIL-P-19468</p> <p>1. CRIMPED FERRULE HEX CRIMP SIZE .128" 2. CONTACT PIN TO SOLDER 3. MAX. PANEL THICKNESS=3.2mm</p>															
8	HEAT SHRINK TUBING		BLACK	1	HT-46/4X15	DIMENSIONS ARE IN MILLIMETERS UNLESS OTHERWISE SPECIFIED TOLERANCES 0.5-6 = ±0.2 6-30 = ±0.4 30-120 = ±0.6 120-315 = ±1 315-1000 = ±1.6 1000-2000 = ±2.4				PART NO. SMA6411A4-3GT50G-5-50		<h1 style="text-align: center;">Amphenol</h1> <p style="text-align: center;">TITLE SMA BULKHEAD CRIMP JACK (FOR RG-174/U,188A/U,316/U)</p> <p style="text-align: center;">DRAWING NO. KJ-SMA6411A4-3GT50G-316U-50</p> <p style="text-align: center;">ITEM NO.</p>					
7	FERRULE	CDPPER	NOTE 3	1	FR-38/3X7C					APPROVED							
6	CONTACT PIN	NOTE 4	NOTE 5	1	SMA87051902-3	CHECKED		DATE 10-11-01'									
5	HEX NUT	NOTE 1	NOTE 3	1	HN8-1/4-36X16	DRAWN		DATE 10-11-01'									
4	LOCK WASHER	NOTE 2	NOTE 3	1	LW-102/65X05												
3	RING	NOTE 1	NOTE 3	1	SMA7071A4-4B												
2	INSULATOR	NOTE 6	NATURAL	1	SMA6411A4-2T-50												
1	BODY	NOTE 1	NOTE 3	1	SMA6411A4-1-23/17												
NO.	DESCRIPTION	MATERIAL	FINISH	Q'TY	DRAWING NO.	SCALE	3/1	ISSUE	A	FILE NO.							