

ENBOSSSED TAPING DRAWING(4:1)  
DIRECTION OF UNREELING

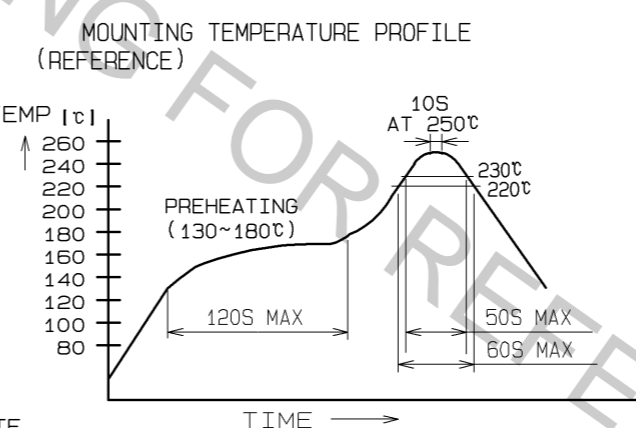

NOTE  
MOUNTING TEMPERATURE PROFILE VARIES ACCORDING TO BOARD SIZE, SOLDER TYPE APPLIED AND SOLDER THICKNESS.  
·METAL MASK THICKNESS: 0.1mm / 0.12mm  
·Up to 2cycles of Reflow.

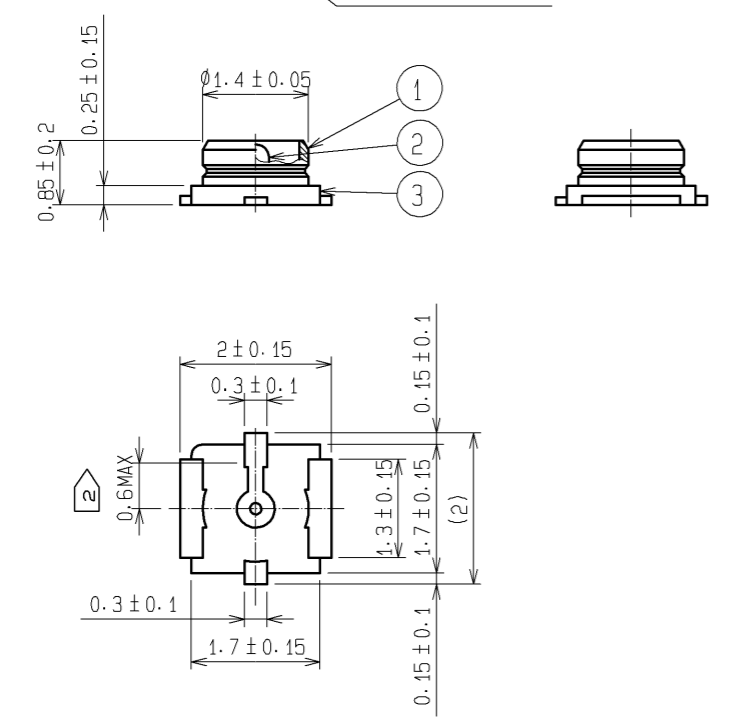
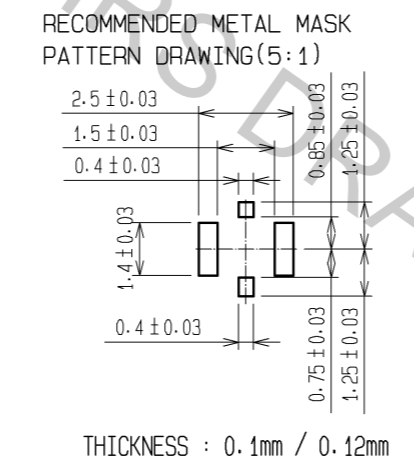
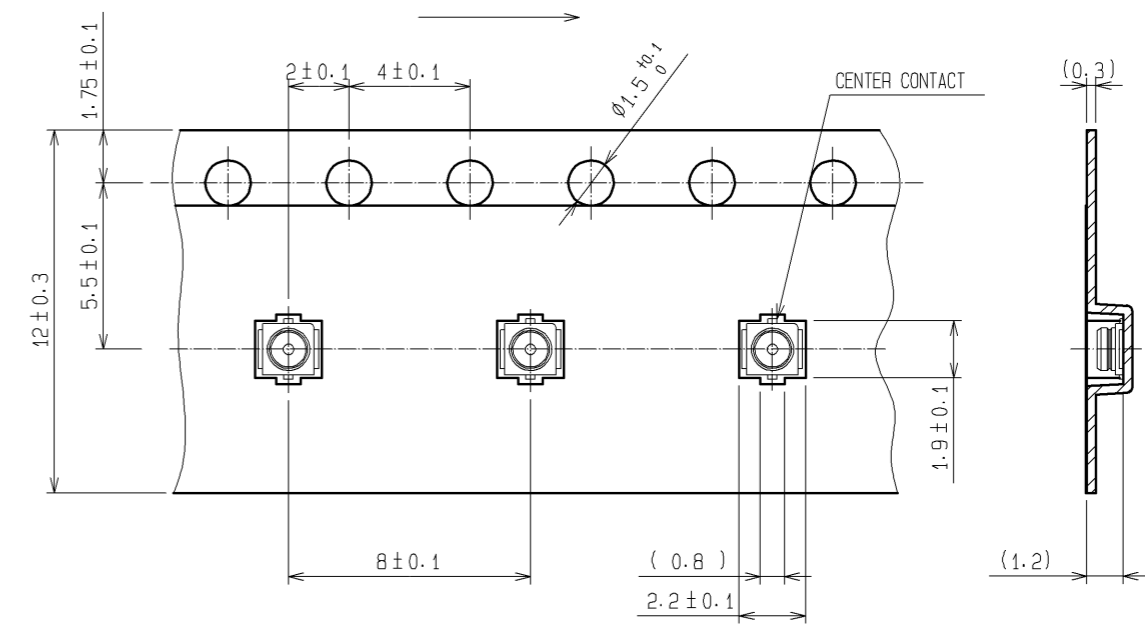
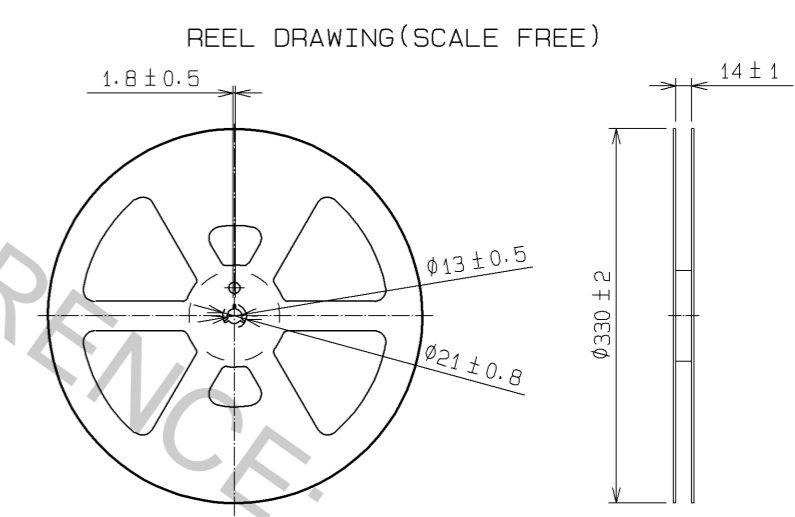

NOTES:

- 1: THE QUANTITY OF W.FL-R-SMT-1(40) IS 5000 CONNECTORS PER REEL.
- 2: THIS DIMENSION SHOWS THE ALLOWABLE RANGE THAT THE RESIN IS PUT OVER THE CENTER CONTACT.
- 3: LEAD CO-PLANARITY SHALL BE 0.1MAX.
- 4: FOR THE POSSIBILITY OF BREAKAGE OR DEFORMATION DO NOT MATE THIS CONNECTOR WITH PARTNER, W.FL-LP-040 BEFORE MOUNTING ON PC BOARD.
- 5: USE ALL PRODUCTS WITHIN 6 MONTHS AFTER THE DELIVERY. STORE THEM IN MANUFACTURER'S PACKAGE OR TIGHTLY RE-CLOSED BOX WITH THE FOLLOWING CONDITIONS. CHECK THE TERMINAL SOLDERABILITY BEFORE USE IF THE PRODUCT HAS BEEN STORED FOR MORE THAN 6 MONTHS.  
TEMPERATURE: -10°C TO +40°C  
HUMIDITY : 15 TO 85% RH.
- 6: ENVIRONMENTAL CONDITIONS DO NOT USE THE PRODUCTS UNDER THE ENVIRONMENTAL CONDITIONS AS SHOWN BELOW DUE TO POSSIBLE PRODUCT DETERIORATION.  
SPECIAL GAS ATMOSPHERE (HYDROGEN SULFIDE GAS, SULFUR SULFIDE GAS AND HYDROGEN CHLORIDE GAS)  
PLACE ATTENTION REQUIRED: HEATING SYSTEM, AREA NEAR HOT SPRING, VOLCANIC MOUNTAIN AND ALIKE.  
WATER SPLACHED AND CONDENSATION PLACES.  
PLACE ATTENTION REQUIRED: HARSH TEMPERATURE CHANGE.

5000PCS/PLASTIC REEL

2	BRASS	GOLD PLATING	3	LCP	(BLACK) · UL94V-0		
1	PHOSPHOR BRONZE	SILVER PLATING					
NO.	MATERIAL	FINISH . REMARKS	NO.	MATERIAL	FINISH . REMARKS		
UNITS		SCALE	COUNT	DESCRIPTION OF REVISIONS	DESIGNED	CHECKED	DATE
mm		10:1	2	DIS-D-001378	YI. FUNADA	NK. NINOMIYA	09. 03. 12
		APPROVED : IJ. MITANI	06. 11. 04	DRAWING NO.		EDC3-138509-40	
HIROSE ELECTRIC CO., LTD.		CHECKED : MH. YAMANE	06. 11. 02	PART NO.		W. FL-R-SMT-1(40)	
		DESIGNED : NK. NINOMIYA	06. 11. 02	CODE NO.		CL331-0482-6-40	
		DRAWN : NK. NINOMIYA	06. 11. 02				