

THIS DRAWING IS UNPUBLISHED. RELEASED FOR PUBLICATION  
 © COPYRIGHT - By - ALL RIGHTS RESERVED.

LOC		DIST		REVISIONS			
P	LTR	DESCRIPTION		DATE	DWN	APVD	
GP	00	C2	REVISED PER ECO-12-014371	12NOV2012	CJV	PAR	

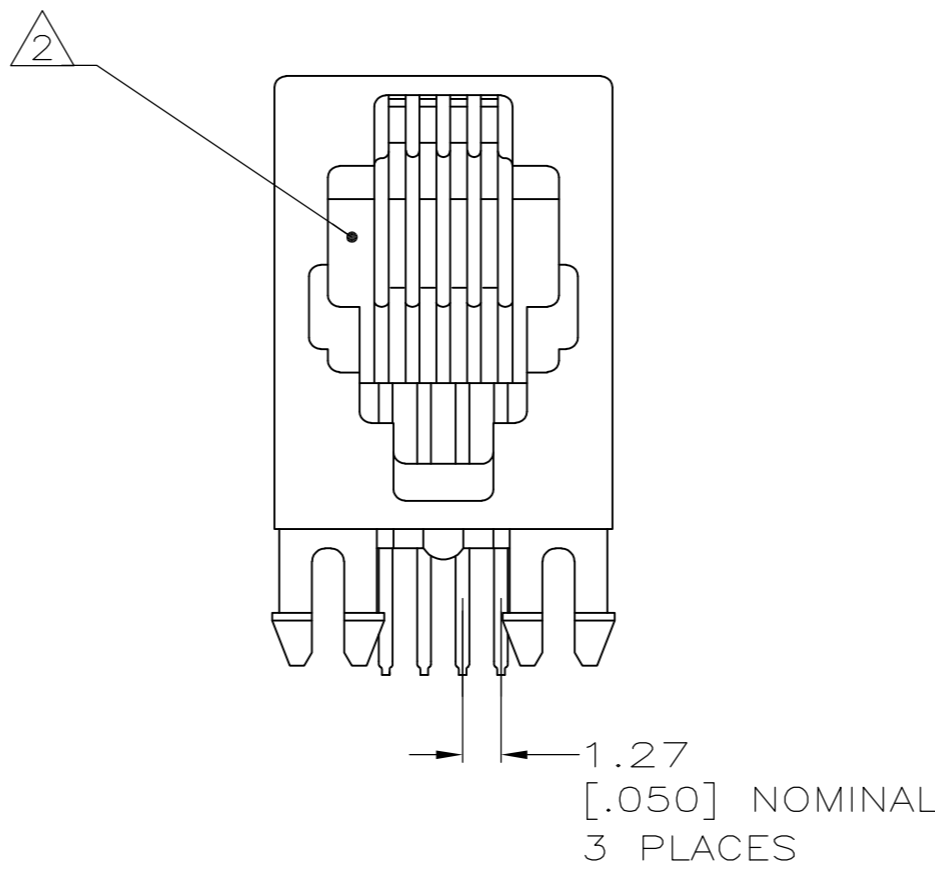

- MATERIAL:  
HOUSING - PBT POLYESTER, COLOR: BLACK  
TERMINAL - 0.36[.014] THICK PHOS BRONZE PLATED WITH (SEE TABLE) MIN HARD GOLD IN LOCALIZED GOLD PLATE AREA AND 3.81µm[.000150] MIN THICK MATTE TIN IN SOLDER AREA OVER 1.27µm[.000050] MIN THICK NICKEL UNDERPLATE
- CAVITY CONFORMS TO FCC RULES AND REGULATIONS PART 68 AND REA BULLETIN 345-81, PE-76 SPECIFICATION FOR MODULAR TELEPHONE HARDWARE.
- DIMENSIONS ARE MAXIMUM UNLESS OTHERWISE SPECIFIED.
- 0.15µm[.000006] GOLD PLATED PARTS DO NOT MEET THE MINIMUM GOLD THICKNESS REQUIREMENT OF FCC SPECIFICATION, PART 68. PARTS HAVE NOT BEEN TESTED TO THE DURABILITY REQUIREMENTS OF TE CONNECTIVITY PRODUCT SPEC 108-1163

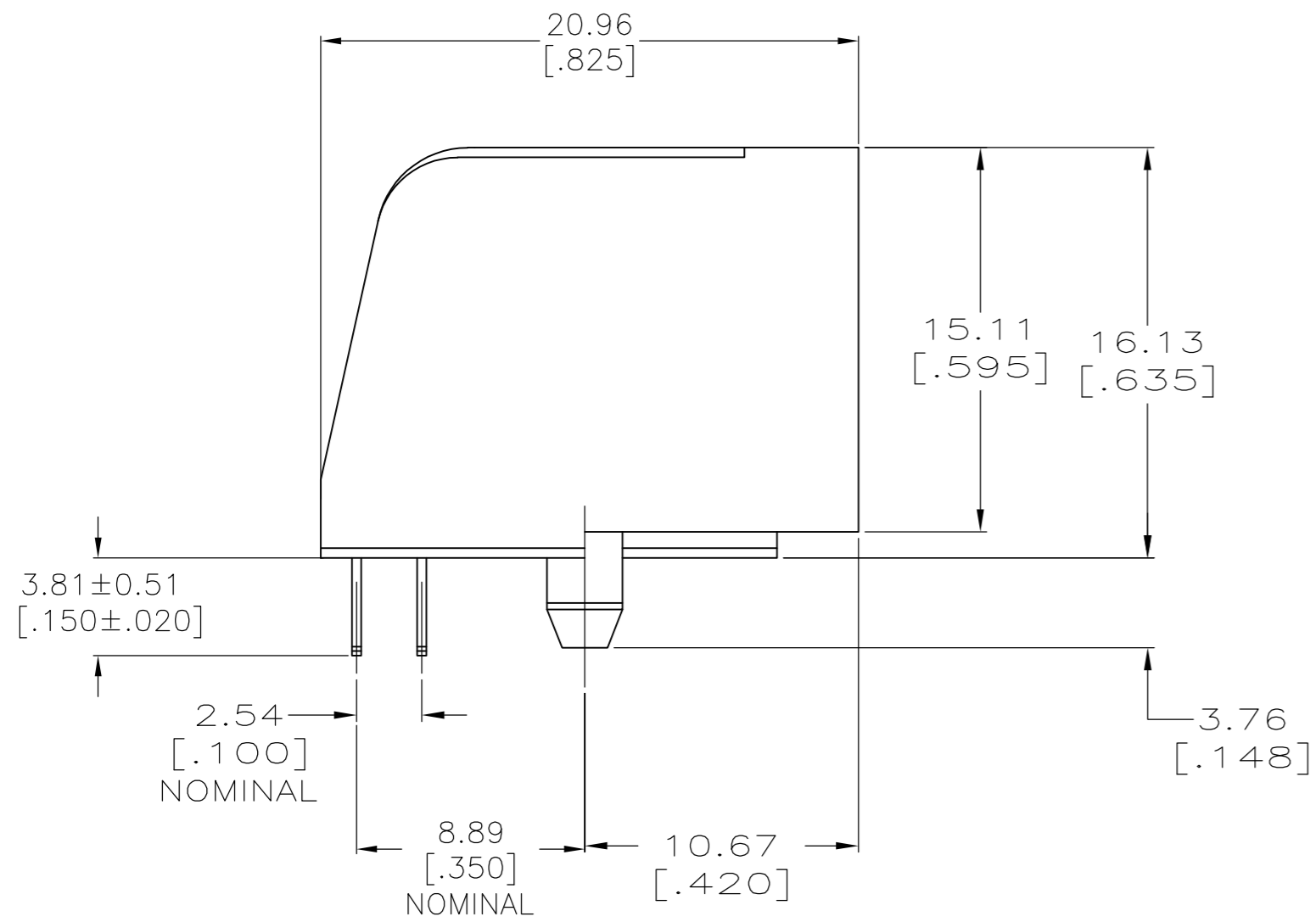
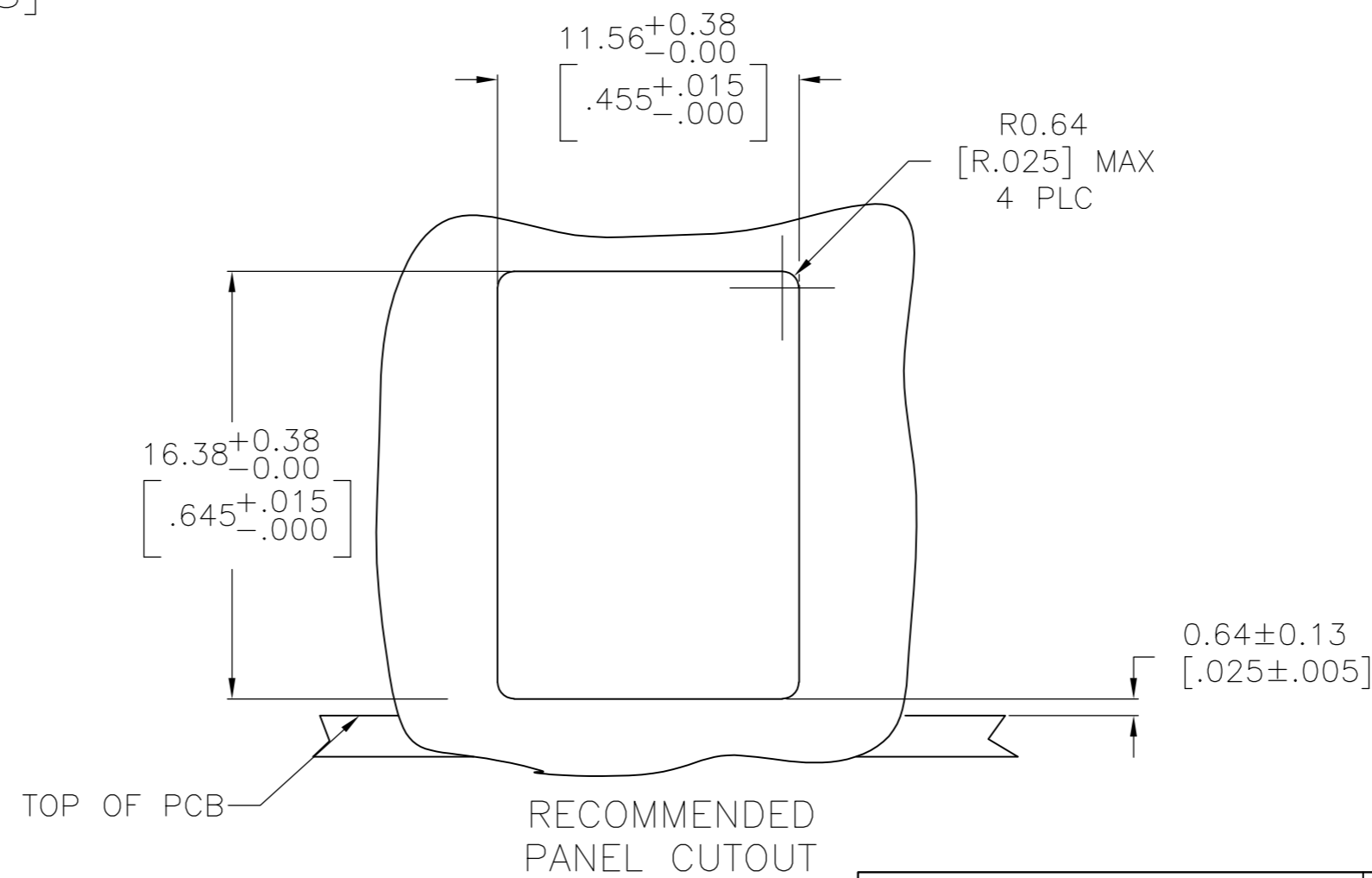
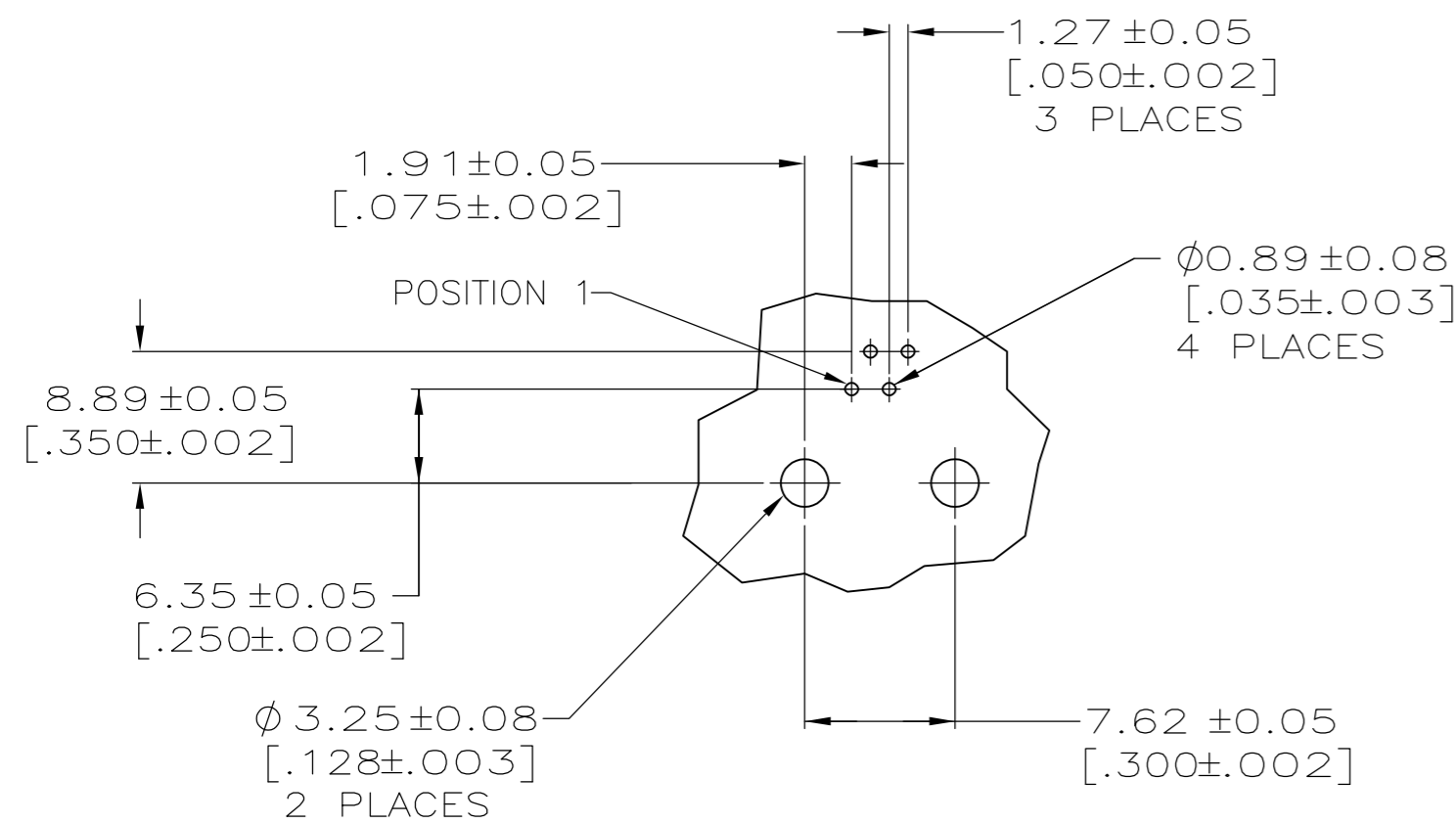
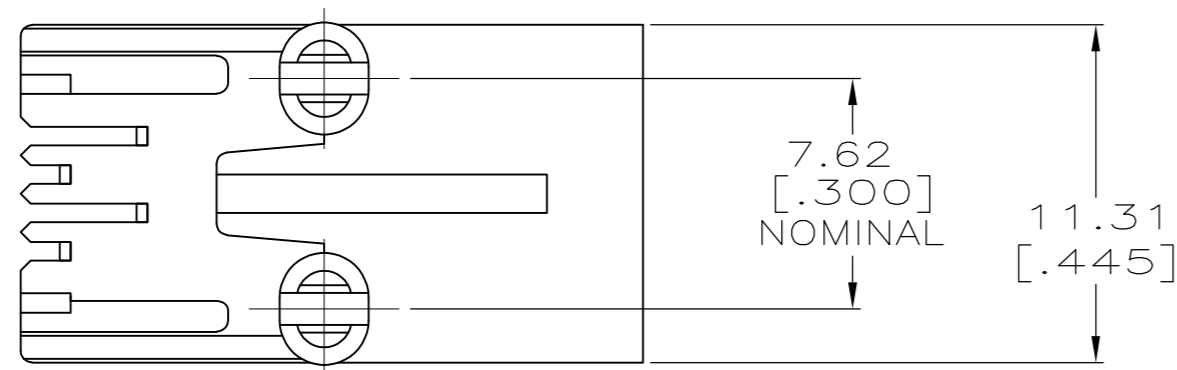

RECOMMENDED PRINTED CIRCUIT BOARD LAYOUT  
 COMPONENT SIDE SHOWN  
 SCALE 2:1

4	OBsolete	0.15µm[.000006]	2-5555980-2
		1.27µm[.000050]	5555980-1
		GOLD THICKNESS	PART NUMBER

THIS DRAWING IS A CONTROLLED DOCUMENT. DIMENSIONING AND TOLERANCING PER ASME Y14.5M-2009		DWN G. ATTADIA - DOCK5 09JUN2005	TE Connectivity	
DIMENSIONS: mm [INCHES]		CHK J. WESTMAN 09JUN2005	NAME	
TOLERANCES UNLESS OTHERWISE SPECIFIED:		APVD S. FLICKINGER 09JUN2005	PRODUCT SPEC	
0 PLC ± -		APPLICATION SPEC		108-1163
1 PLC ± -		WEIGHT		114-2048
2 PLC ± -		CAGE CODE		A2 00779
3 PLC ± 0.13[.005]		DRAWING NO		C=5555980
4 PLC ± -		RESTRICTED TO		-
ANGLES ± -		SCALE		1:1
FINISH		SHEET		1 of 1
SEE NOTE 1		REV		C2
CUSTOMER DRAWING				