

TOGGLE SWITCHES

PRODUCT NUMBER 0100.1201



TECHNICAL DATA

Product number	0100.1201
Actuator color / printing	
Product family	Toggle switches
Actuation type	direct
Weight	14.500 g
ROHS conform	yes
Switching function	ON / OFF switch (SPST)
Material fixed contact	CuZn silver-plated
Number of poles	1 - pole
connections	Solder terminal
Mechanical life endurance	5E4
Rating IEC	2 A 250 V 1E3
Actuators and additional actuators	lever: PA, black
Housing description	base plate: Duroplast, black bracket plate: Duroplast (base) / chromated galvanized steel (bracket plate) threaded socket: CnZn nickel-plated, with knurled nut and hexagonal nut of nickel-plated CuZn
Connection surface	→ bearing connection silver plated

	→ external connection	silver plated
Contact material	CuZn silver plated	
Contact distance	≥ 3 mm	
Contact type	jump contact (roll contact)	
Miscellaneous	actuating torque 45.0 ±14.0 Nmm	
Type of fastening	central fastening M12 x 0.75	
Stock version	●	

PRODUCT IMAGE



DRAWINGS

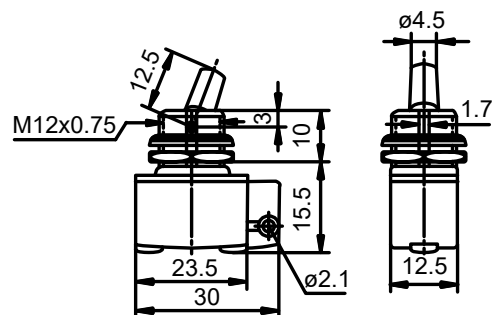

Technical changes reserved. Dimensions are not binding.
Detailed specifications available on request.

Marquardt GmbH · Schloss-Straße 16 · 78604 Rietheim-Weilheim · Germany
Phone: +49 (0) 7424 / 99-0 · Fax: +49 (0) 7424 / 99-2399 · www.marquardt.com · marquardt@marquardt.de