

LEVER STRAIGHT

PRODUCT NUMBER 0.191071101



TECHNICAL DATA

Product number	191.071.101	
Product family	lever straight	
Accessories Category	Levers	
ROHS conform	yes	
Link description	1045./1050. with normal lever	
Dimensions	→ Length	19.7 mm
	→ Width	3.4 mm
Actuators and additional actuators	stainless steel spring steel, L03	
Free position (FP) max.	19.5 mm	
Operating position (OP)	11.5 ±4 mm	
Permissible total travel position	5 mm	
Miscellaneous	Values of the permissible total travelled position and of the operating position are valid for switches until maximum 1.5 N actuating force on the actuator. Different forces cause different lever deflections.	

PRODUCT IMAGE

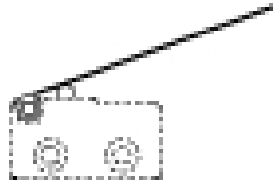

(Similar to original product)

DRAWINGS

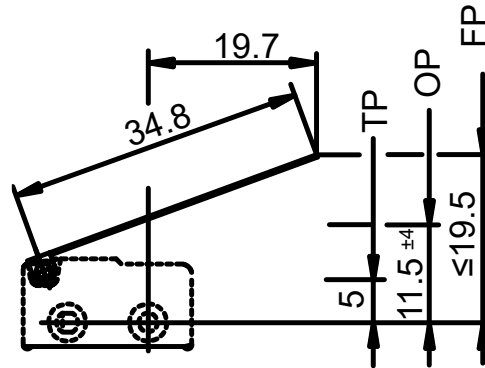

Technical changes reserved. Dimensions are not binding.

Detailed specifications available on request.

Marquardt GmbH · Schloss-Straße 16 · 78604 Rietheim-Weilheim · Germany
Phone: +49 (0) 7424 / 99-0 · Fax: +49 (0) 7424 / 99-2399 · www.marquardt.com · marquardt@marquardt.de