

Specification

Client Name : _____

Client P/N : OF-SMD3535UV-A

Product P/N : _____

Sending Date: _____



ATTENTION
OBSERVE PRECAUTIONS
FOR HANDLING
ELECTROSTATIC
DISCHARGE
SENSITIVE
DEVICES

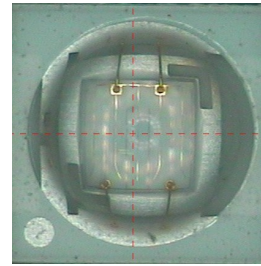

Features

Dimension : 3.45mm×3.45mm×1.9mm

Viewing angle : 120°

RoHS compliant

Anti-vulcanization

Reflow Solder-able

Applications

Curing

Security, Banknote

Tanning

Lithography

Sensing

Package Dimensions

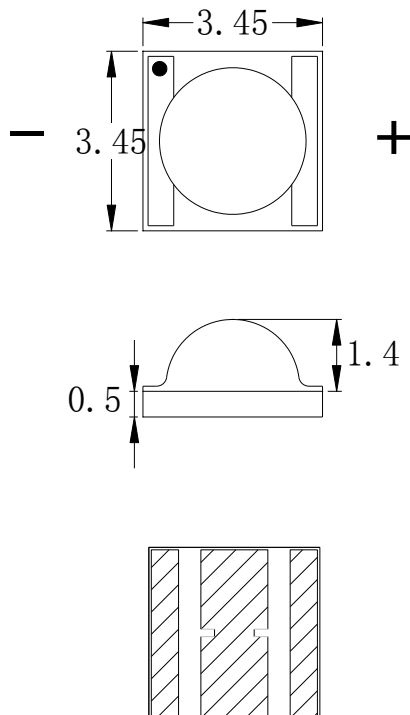

Recommended Soldering

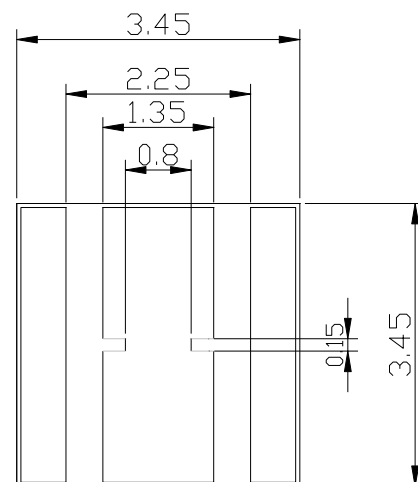

Notes :

1. All dimension units are millimeters.
2. All dimension tolerance is ± 0.2 mm unless otherwise noted.

Radiation Pattern

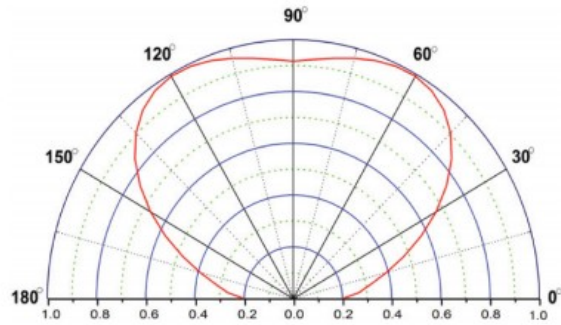

Typical Optical/ Electrical Characteristics @T_a=25°C

Parameters 参数	Symbol	Forward Current I _F	Min.	Typ.	Max.	Unit
Forward Voltage 正向电压	V _F	@350mA	3.3	3.4	—	V
Optical Power 光功率	P _{out}	@350mA	120	135	—	mW
Peak Wavelength 峰值波长	λ _p	@350mA	361	367	371	—
FWHM 半峰宽	—	@350mA	9	10	—	nm
Lifetime 寿命	L(50)	@350mA	1500	2000	—	Hour

Notes注:

1. Tolerance of measurement of forward voltage±0.1V、peak Wavelength±2.0nm、luminous power±5%

Absolute Maximum Ratings

Parameter参数	Symbol	Rating Value	Units.
Input power 输入功率	P _i	1.31	W
Maximum operating current 最大工作电流	I _{Fmax}	350	mA
Junction Temperature 结温	T _j	115	°C
Operating Temperature Range 工作温度	T _{op}	-20°C To +45°C	
Storage Temperature Range 储藏温度	T _{stg}	-40°C To +80°C	
Lead Soldering Temperature* 引线焊接温度	T _{sol}	Max. 350°C for 5sec Max.	

Note:

1. The temperature of Aluminum PCB do not exceed 45°C

Typical Optical/Electrical Characteristics Curves ($T_a=25^\circ\text{C}$ Unless Otherwise Noted)

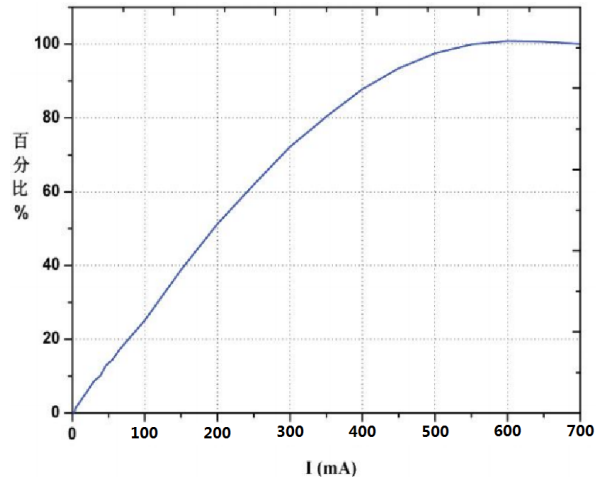
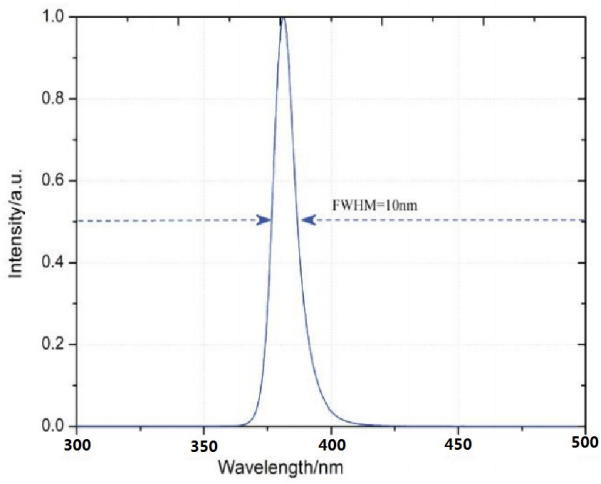

Po vs IF

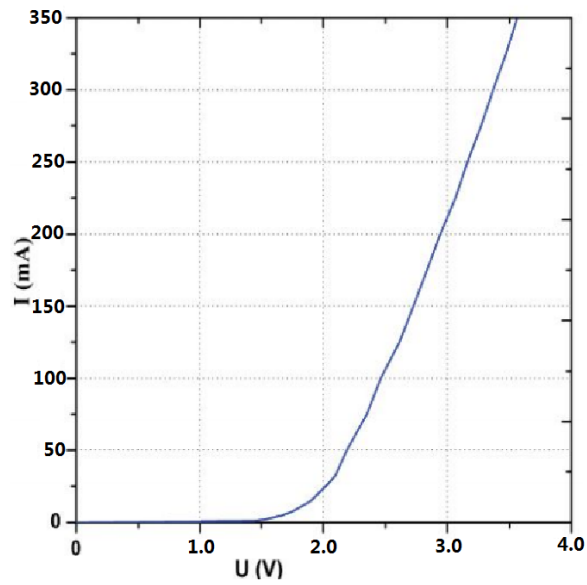

U-I

Soldering :

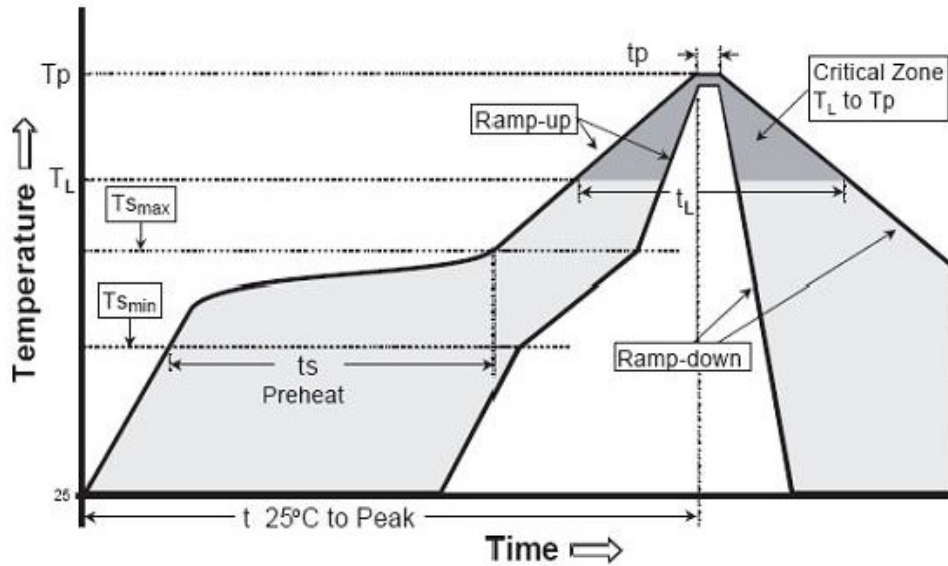

Reflow soldering

Caution

1. wave peak and soak-stannum soldering etc. is not suitable for this products.
2. reflow soldering should not be done more than one time
3. The peak reflow temperature is $180 \pm 10^{\circ}\text{C}$, not more than 40 seconds
4. Repairing should not be done after the LEDs have been soldered. When repairing is unavoidable, suitable tools have to be used.
5. when soldering, do not put stress on the LEDs during heating.
6. After soldering, do not warp the LED. do not stack PCBs or assemblies containing K Series LEDs so that anything rests on the LED lens.

Test

1. All ultraviolet LED products mounted on aluminum metal-core printed circuit board, can be lighted directly, but we do not recommend lighting the high power products for more than 5 seconds without a appropriate heat dissipation equipment.

Label

RoHS		
TYPE:		QTY:
VF:	IF:	λ_p :
P_{out} :		
DATE:	LOT.NO:	

P_{out} : Optical Power

VF: Forward voltage rank

λ_p : Peak Wavelength

Tape Specifications(Units:mm)

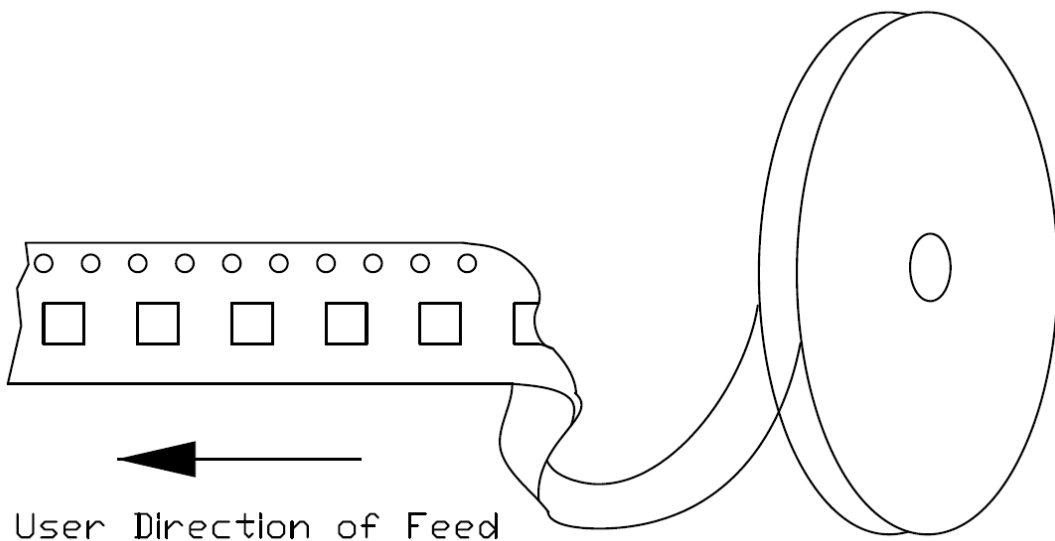
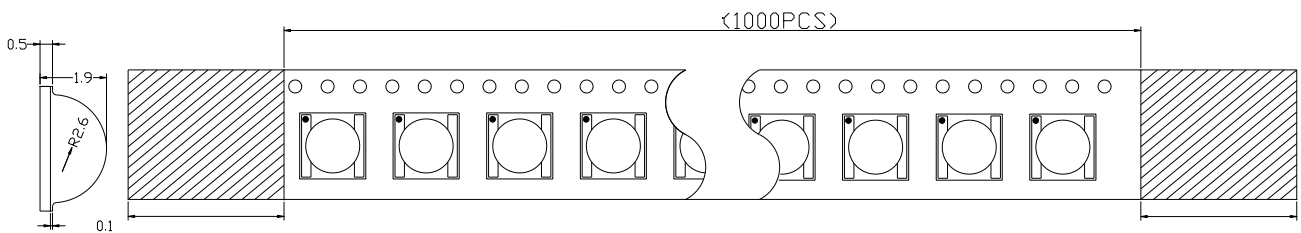

Packing



Reel: 2000pcs

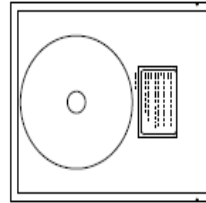
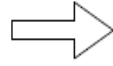

1Reel/ESD Shilding Bag

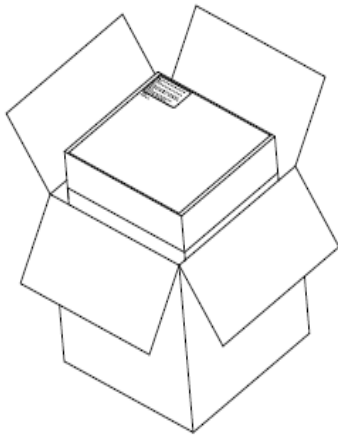

5 Inner Box/Outer Box: 50000pcs

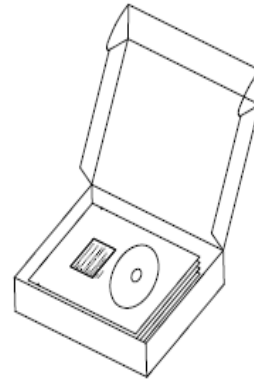
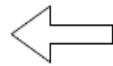

5Bags/Inner box:10000pcs

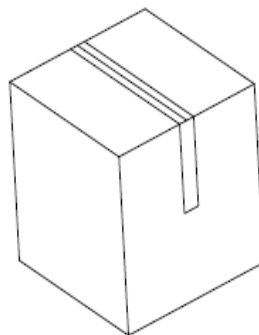

Outer Box50000pcs

Precaution for use

1.Storage

To avoid the moisture penetration ,we recommend storing LEDs in a dry box (or a desiccator) with a desiccant. The recommended conditions are temperature 5 to 30 degrees Centigrade. Humidity 60% maximum.

2.Precaution after opening packing:

2.1.Soldering should be done right after opening the package (within 24Hrs).

2.2.Keeping of a fraction.

-Sealing

-Temperature: 5~30°C ; Humidity: less than 30%

2.3.If the package has been opened than 1 week or the color of desiccant changed, components should be dried for 10-12 Hrs at 60±5°C

3.Any mechanical force or any excess vibration shall not be accepted to apply during cooling process to normal temperature after soldering.

4.Please avoid rapid cooling after soldering.

5.Components should not be mounted on warped direction of PCB.

6.This device should not be used in any fluid such as water, oil ,organic solvent etc. When washing is required, Isopropyl Alcohol should be used.

7.Avoid touching Lens parts especially by sharp tools such as pincette.

8.Please do not force over 1000g impact or pressure diagonally on the silicone lens. It will cause fatal damage on this product.

9.Please do not cover the silicone resin of the LEDs with other resin.

10.Do not use metal suction nozzle, rubber or silica gel suction nozzle is recommended.

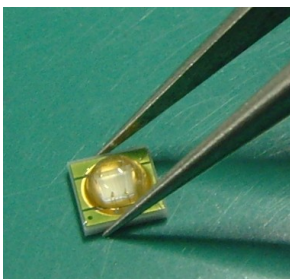

OK

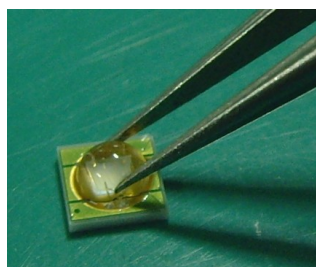

NG

Note:

1. $2\theta_{1/2}$ is the angle from optical centerline where the luminous power is 1/2 the optical centerline value.

3.The value only for reference.

13. Do not stack PCBs or assemblies containing the LEDs so that anything rests on the LED lens. Force applied to the LED lens may result in the lens being knocked off. PCBs or assemblies containing the LEDs should be stacked in a way to allow at least 2 cm clearance above the LED lens.

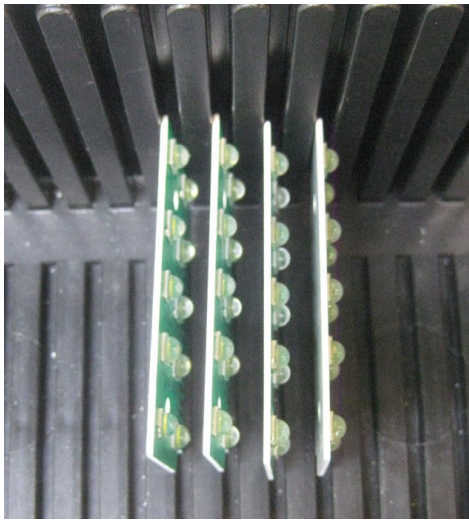

OK



OK

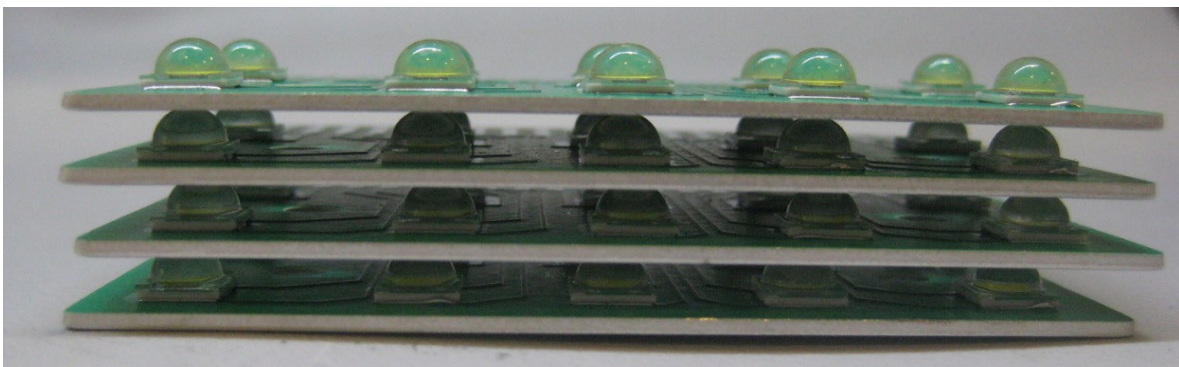

NG