



RAYSTAR

曜凌光電股份有限公司

住址: 42878 台中市大雅区科雅路 25 號 5F WEB: <http://www.Raystar-Optronics.com>
5F., No.25, Keya Rd., Daya Dist., Taichung E-mail: sales@raystar-optronics.com
City 428, Taiwan Tel:886-4-2565-0761 Fax : 886-4-2565-0760

RFP620A-6XW-DNN

SPECIFICATION

CUSTOMER:

APPROVED BY	
PCB VERSION	
DATE	

FOR CUSTOMER USE ONLY

SALES BY	APPROVED BY	CHECKED BY	PREPARED BY

Release DATE:

TFT Display Inspection Specification: <https://www.raystar-optronics.com/download/products.htm>

Precaution in use of TFT module: <https://www.raystar-optronics.com/download/declaration.htm>

Revision History

VERSION	DATE	REVISED PAGE NO.	Note
0	2015/10/14		First issue
A	2016/01/21		Modify Static electricity test
B	2016/08/11		Modify Vibration test
C	2017/08/15		Modify Summary Add Aspect Ratio

RAYSTAR OPTRONICS

Contents

1. Module Classification Information
2. Summary
3. General Specification
4. Interface
5. Contour Drawing
6. Block Diagram
7. Absolute Maximum Ratings
8. Electrical Characteristics
9. DC Characteristics
10. AC Characteristics
11. Optical Characteristics
12. Reliability
13. Package Specification
14. Initial Code For Reference
15. Other

RAYSTAR OPTRONICS

2.Summary

The 6.2 " VA Mono TFT that is offers improved contrast ,viewing angle, brightness and response time over traditional passive monochrome products. Increased display brightness display brightness is a key factor for design engineers when selecting a display that must vividly show pictures and alphanumeric data.The TFT cell is manufactured using high aperture panel technology and high transmission polarizer. The result is a clear and extremely bright display.

RAYSTAR OPTRONICS

3.General Specifications

- Size: 6.2 inch
- Dot Matrix: 640 x 320 dots
- Module dimension: 170.32 x 88.3 x 5.3 mm
- Active area: 140 x 70 mm
- Dot pitch: 0.21875 x 0.21875 mm
- LCD type: TFT, Normally Black, Transmissive
- View Direction: Wide View
- Aspect Ratio: 16:9
- Gray Scale: 16 Gray scale (4BPP)/ 4 Gray scale (2BPP)/ 2 Gray scale (1BPP)
- Controller IC: ST7511U
- Backlight Type: LED, Normally White
- With /Without TP: Without TP
- Surface: Glare

* Mono tone slight changed by temperature and driving voltage.

4.Interface

4.1. LCM PIN Definition

Pin	Symbol	Function	Remark
1	GND	System ground	
2	VDD	Power Supply : +3.3V	
3	NC	No connect	
4	A0	Data/Command select	
5	/WR(R/W)	Write strobe signal	
6	/RD(E)	Read strobe signal	
7	DB0	Data bus	
8	DB1	Data bus	
9	DB2	Data bus	
10	DB3	Data bus	
11	DB4	Data bus	
12	DB5	Data bus	
13	DB6	Data bus	
14	DB7	Data bus	
15	/CS	Chip select	
16	/RESET(RSTB)	Hardware reset	
17	IF0	Mode select	Note1
18	IF1		
19	NC	No connect	
20	NC	No connect	
21	NC	No connect	
22	NC	No connect	

Note1:

Setting		MCU Type	Interface Pin Function				
IF1	IF0		CSB	A0	RWR	ERD	D[7:0]
L	L	Parallel 8080 series MCU	CSB	A0	/WR	/RD	D[7:0]
L	H	Parallel 6800 series MCU			R/W	E	D[7:0]
H	H	Serial 4-Line series MCU			-	-	D7=SCL, D0=SDA, D[6:1] are not used
H	L	Serial 3-Line series MCU			-	-	

The un-used pins are marked as “-” and should be connected to “H” by VDDI.

4.2. Backlight Unit Section(CN2)

LED Light Bar connector is used for the the integral backlight system. The recommended model is “JST XH-3” manufactured by JST.

Pin No.	Symbol	I/O	Function	Remark
1	V _{LED+}	P	Power for LED backlight anode (A)	Red
3	V _{LED-}	P	Power for LED backlight cathode (K)	Black

5. Contour Drawing

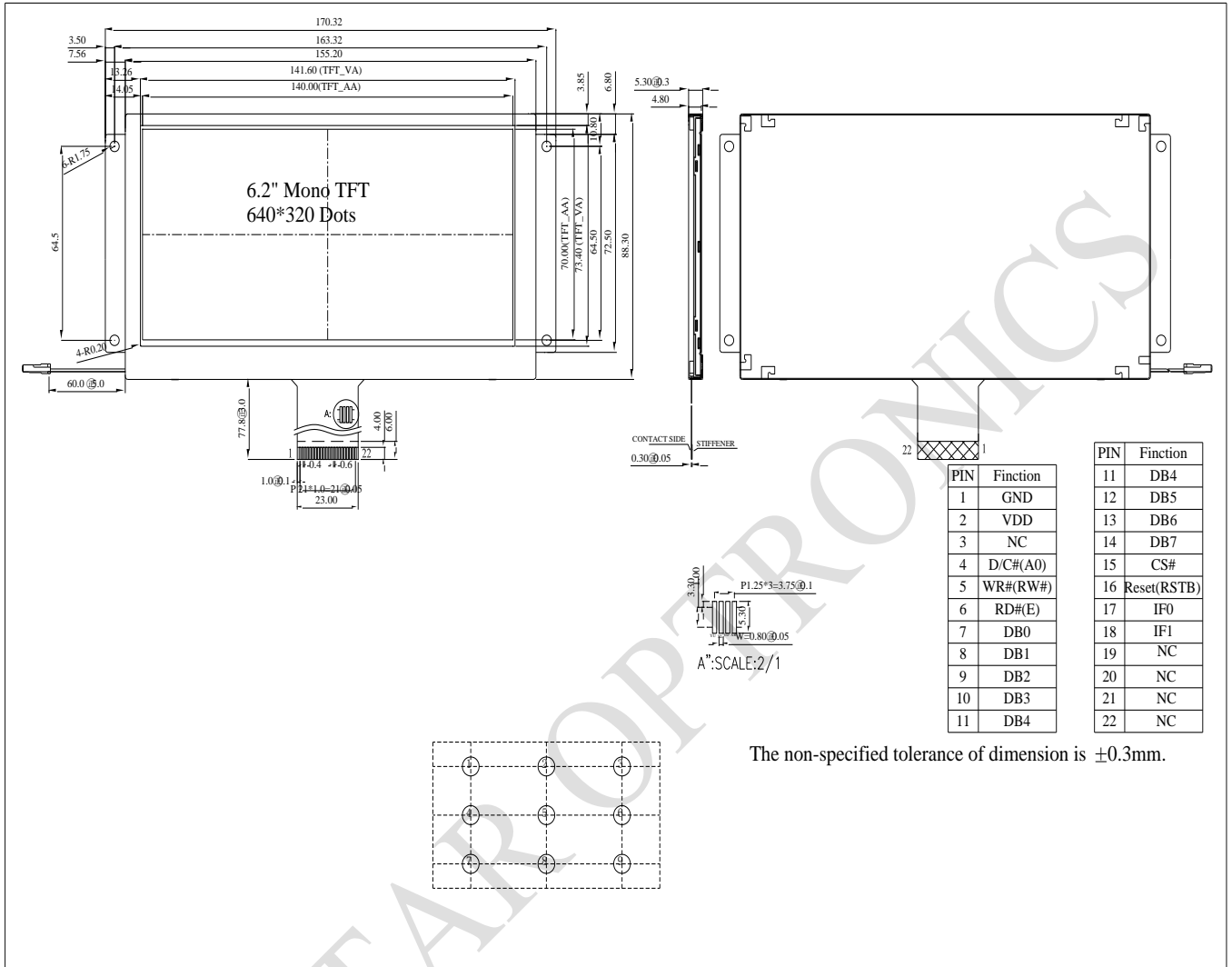

7. Absolute Maximum Ratings

Item	Symbol	Min	Typ	Max	Unit
Operating Temperature	TOP	-20	—	+70	°C
Storage Temperature	TST	-30	—	+80	°C

Note: Device is subject to be damaged permanently if stresses beyond those absolute maximum ratings listed above

- Temp. $\leq 60^{\circ}\text{C}$, 90% RH MAX. Temp. $> 60^{\circ}\text{C}$, Absolute humidity shall be less than 90% RH at 60°C

RAYSTAR OPTRONICS

8. Electrical Characteristics

8.1. Operating conditions:

Item	Symbol	Condition	Min	Typ	Max	Unit	Remark
Supply Voltage For LCM	VDD	—	3.0	3.3	3.6	V	
Supply Current For LCM	IDD	—	—	25	38	mA	Note1
Power Consumption	—	—	—	83	137	mW	

Note1: This value is test for VDD=3.3V only

8.2. LED driving conditions

Parameter	Symbol	Min.	Typ.	Max.	Unit	Remark
LED current		-	160	-	mA	
Power Consumption		1392	-	1680	mW	
LED voltage	A-K	8.7	9.6	10.5	V	Note 1
LED Life Time		-	20,000	-	Hr	Note 2,3,4

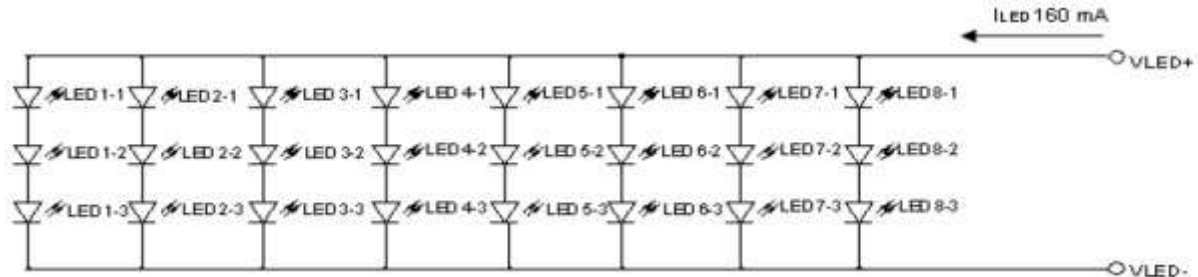

Note 1 : Power supply the back light specification

Note 2 : Ta = 25 °C

Note 3 : Brightness to be decreased to 50% of the initial value

Note 4 : The single LED lamp case

9.DC CHARATERISTICS

Parameter	Symbol	Rating			Unit	Condition
		Min	Typ	Max		
Low level input voltage	V_{IL}	0	-	0.3VDD	V	
High level input voltage	V_{IH}	0.7VDD	-	VDD	V	

RAYSTAR OPTRONICS

10.AC CHARATERISTICS

10.1. System Bus Timing for 6800 Series MPU

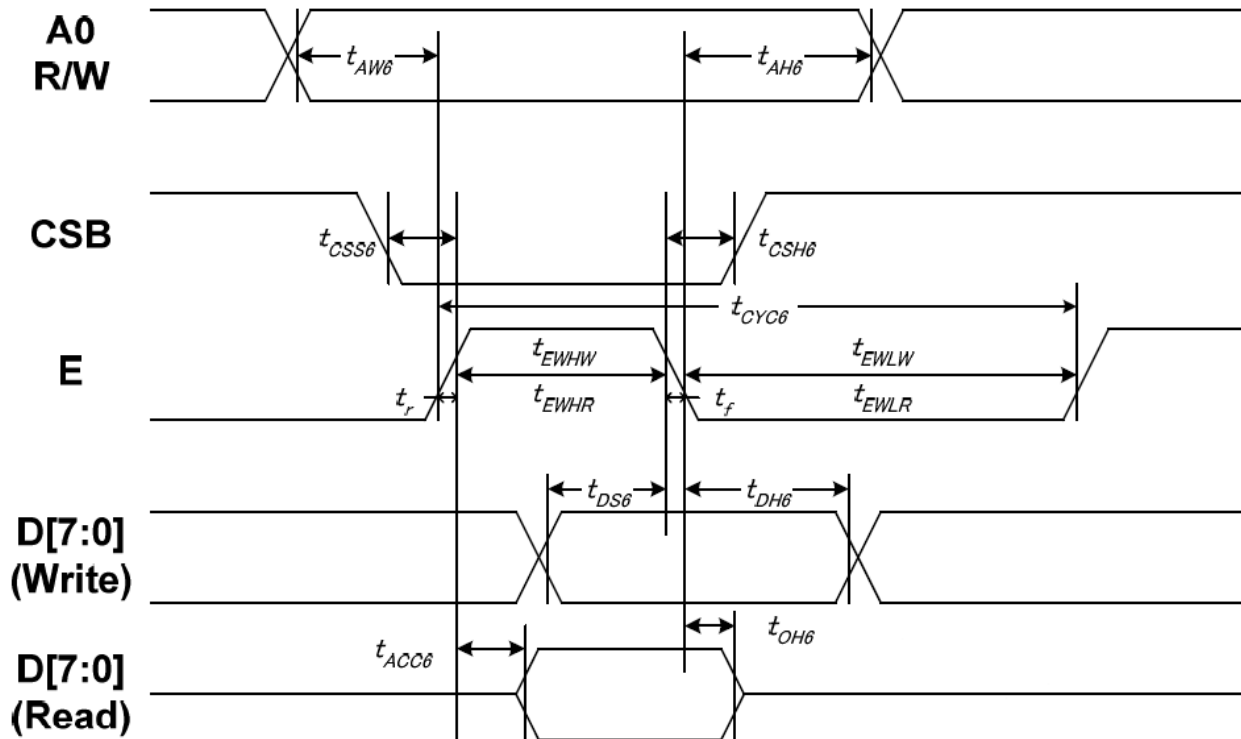

Item	Signal	Symbol	Condition	Min	Max	Unit
Address setup time	A0	t_{AW6}	-	10	-	ns
Address hold time		t_{AH6}	-	0	-	
System cycle time		t_{CYC6}	-	200	-	
Enable L pulse width (WRITE)	E	t_{EHLW}	-	100	-	
Enable H pulse width (WRITE)		t_{EWHW}	-	100	-	
Enable L pulse width (READ)		t_{EHLR}	-	130	-	
Enable H pulse width (READ)		t_{EWHR}	-	130	-	
CSB setup time	CSB	t_{CSS6}	-	100	-	
CSB hold time		t_{CSH6}	-	100	-	
Write data setup time	D[7:0]	t_{DS6}	-	70	-	
Write data hold time		t_{DH6}	-	20	-	
Read data access time		t_{ACC6}	CL = 100 pF	-	80	
Read data output disable time		t_{OH6}	CL = 100 pF	15	80	

Note:

1. The input signal rise time and fall time (t_r , t_f) is specified at 15 ns or less. When the system cycle time is extremely fast, $(t_r + t_f) \leq (t_{CYC6} - t_{CCLW} - t_{CCHW})$ for $(t_r + t_f) \leq (t_{CYC6} - t_{CCLR} - t_{CCHR})$ are specified.
2. All timing is specified using 20% and 80% of VDD1 as the reference.
3. t_{CCLW} and t_{CCLR} are specified as the overlap between CSB being "L" and /WR and /RD being at the "L" level. CSB and /WR (or /RD) cannot act at the same time and CSB should be 100ns wider than /WR (or /RD).

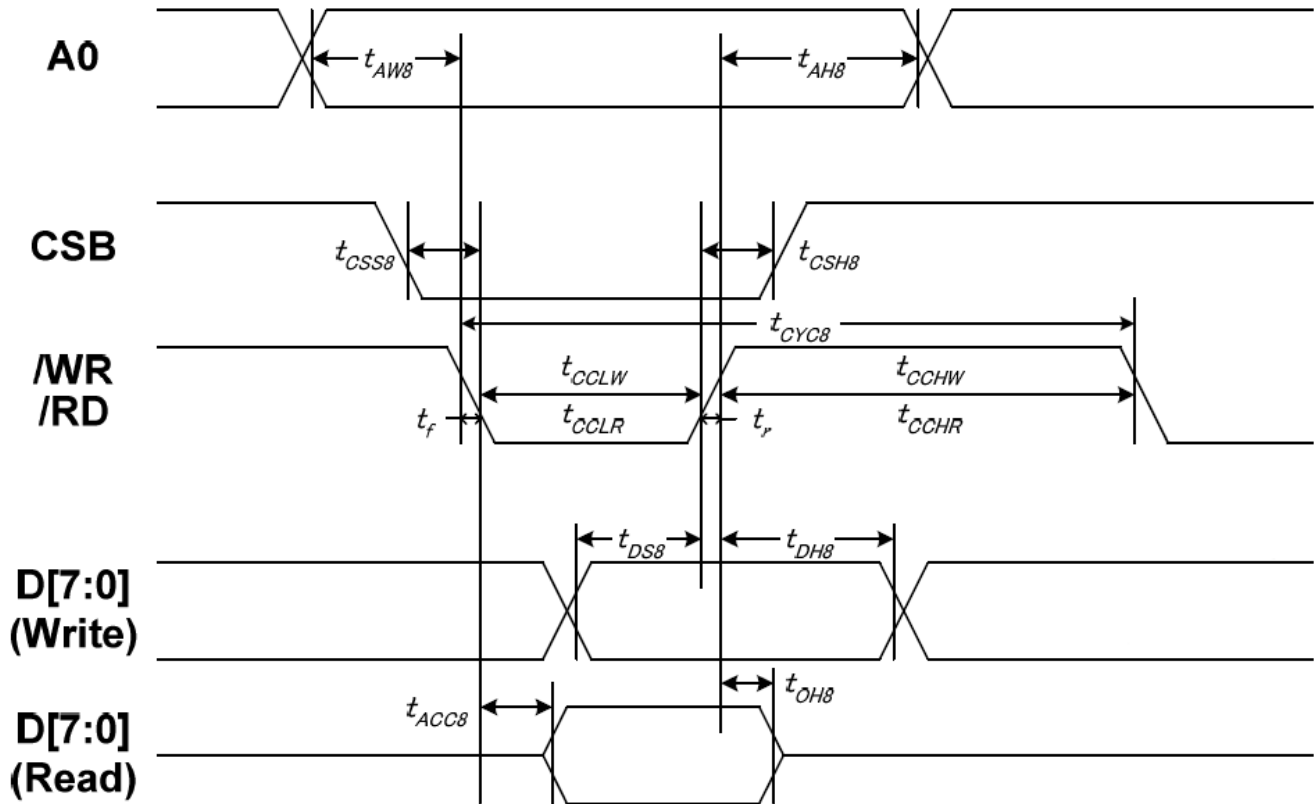
10.2. System Bus Timing for 8080 Series MPU

Item	Signal	Symbol	Condition	Min	Max	Unit
Address setup time	A0	tAW8	-	10	-	ns
Address hold time		tAH8	-	0	-	
System cycle time		tCYC8	-	200	-	
/WR L pulse width (WRITE)	/WR	tCCLW	-	100	-	
/WR H pulse width (WRITE)		tCCHW	-	100	-	
/RD L pulse width (READ)	/RD	tCCLR	-	120	-	
/RD H pulse width (READ)		tCCHR	-	120	-	
CSB setup time	CSB	tCSS8	-	100	-	
CSB hold time		tCSH8	-	100	-	
Write data setup time	D[7:0]	tDS8	-	70	-	
Write data hold time		tDH8	-	20	-	
Read data access time		tACC8	CL = 100 pF	-	80	
Read data output disable time		tOH8	CL = 100 pF	15	80	

Note:

- The input signal rise time and fall time (t_r , t_f) is specified at 15 ns or less. When the system cycle time is extremely fast, $(t_r + t_f) \leq (t_{CYC8} - t_{CCLW} - t_{CCHW})$ for $(t_r + t_f) \leq (t_{CYC8} - t_{CCLR} - t_{CCHR})$ are specified.
- All timing is specified using 20% and 80% of VDDI as the reference.
- t_{CCLW} and t_{CCLR} are specified as the overlap between CSB being "L" and /WR and /RD being at the "L" level. CSB and /WR (or /RD) cannot act at the same time and CSB should be 100ns wider than /WR (or /RD).

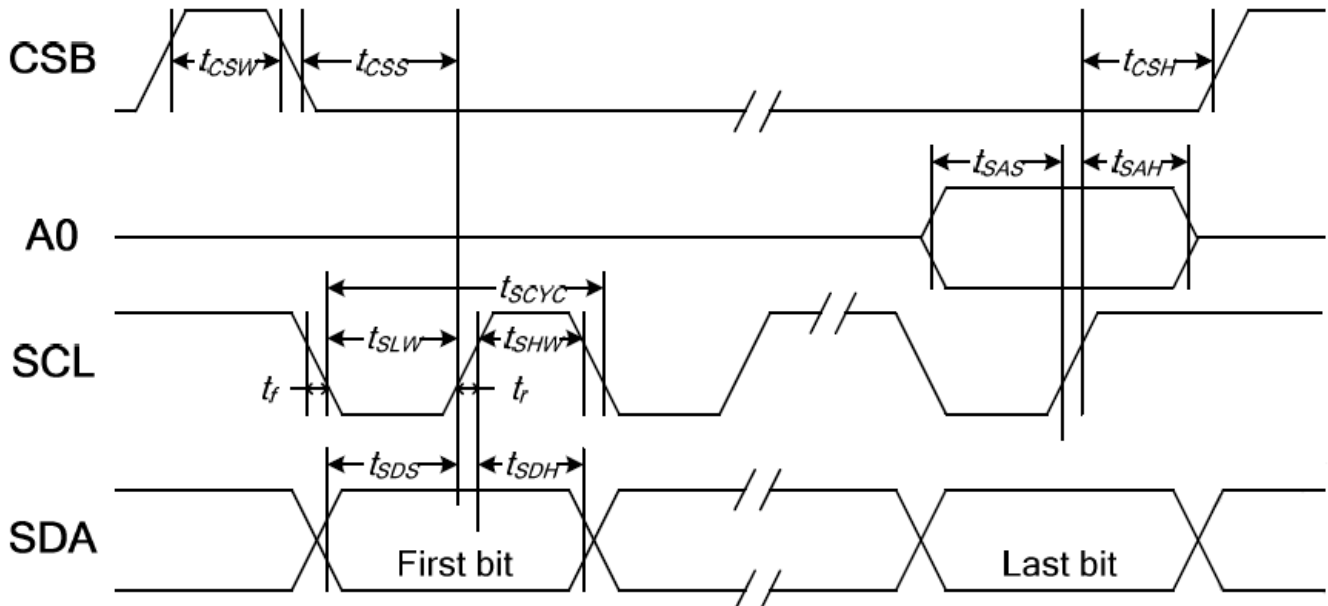
10.3. System Bus Timing for 4-Line Serial Interface

Item	Signal	Symbol	Condition	Min	Max	Unit
Serial clock period		tSCYC	-	80	-	ns
SCL "H" pulse width	SCL	tSHW	-	40	-	
SCL "L" pulse width	SCL	tSLW	-	40	-	
Address setup time	A0	tSAS	-	40	-	
Address hold time	A0	tSAH	-	40	-	
Data setup time	SDA	tSDS	-	15	-	
Data hold time	SDA	tSDH	-	20	-	
CSB-SCL time		tCSS	-	40	-	
CSB-SCL time	CSB	tCSH	-	40	-	
CSB "H" pulse width	CSB	tCSW	-	15	-	

Note:

1. The input signal rise and fall time (t_r , t_f) are specified at 15 ns or less.
2. All timing is specified using 20% and 80% of VDDI as the standard.

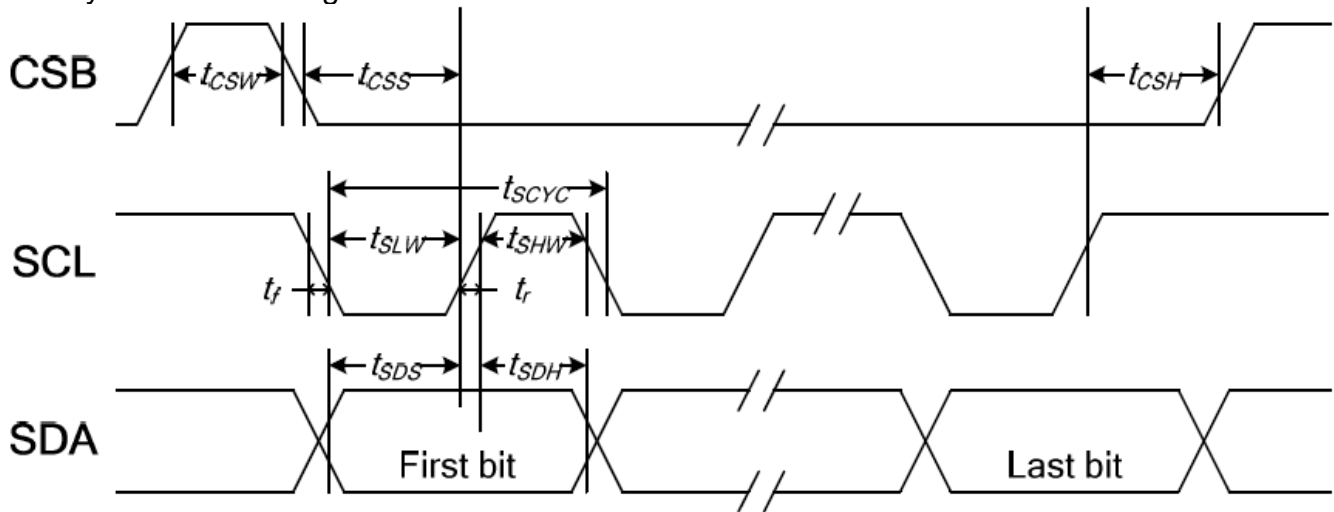
10.4. System Bus Timing for 3-Line Serial Interface

Item	Signal	Symbol	Condition	Min	Max	Unit
Serial clock period		t_{SCYC}	-	80	-	ns
SCL "H" pulse width	SCL	t_{SHW}	-	40	-	
SCL "L" pulse width	SCL	t_{SLW}	-	40	-	
Data setup time	SDA	t_{SDS}	-	15	-	
Data hold time	SDA	t_{SDH}	-	20	-	
CSB-SCL time		t_{CSS}	-	40	-	
CSB-SCL time	CSB	t_{CSH}	-	40	-	
CSB "H" pulse width	CSB	t_{CSW}	-	15	-	

Note:

1. The input signal rise and fall time (t_r , t_f) are specified at 15 ns or less.
2. All timing is specified using 20% and 80% of V_{DDI} as the standard.

11. Optical Characteristics

Item	Symbol	Temp	Condition.	Min	Typ.	Max.	Unit	Remark
Response time	Tr	25°C	$\theta=0^\circ$ 、 $\Phi=0^\circ$	-	8	-	.ms	Note 3
	Tf	25°C		-	12	-		
Contrast ratio	CR	25°C	At optimized viewing angle	-	800	-	-	Note 4
Viewing angle (Gray Scale Inversion Direction)	Hor.	Θ_R	25°C	CR \geq 10	80		Deg.	Note 1 Note 2
		Θ_L	25°C		80			
	Ver.	Φ_B	25°C		80			
		Φ_T	25°C		80			
Brightness	-	25°C	-	500	600	-	cd/m ²	Center of display

Ta=25±2°C, IL=160mA

Note 1: Definition of viewing angle range

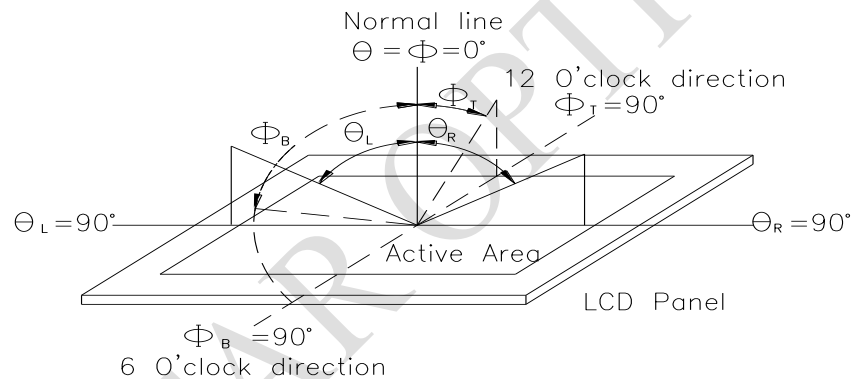

Fig.11.1. Definition of viewing angle

Note 2: Test equipment setup:

After stabilizing and leaving the panel alone at a driven temperature for 10 minutes, the measurement should be executed. Measurement should be executed in a stable, windless, and dark room. Optical specifications are measured by Topcon BM-7orBM-5 luminance meter 1.0° field of view at a distance of 50cm and normal direction.

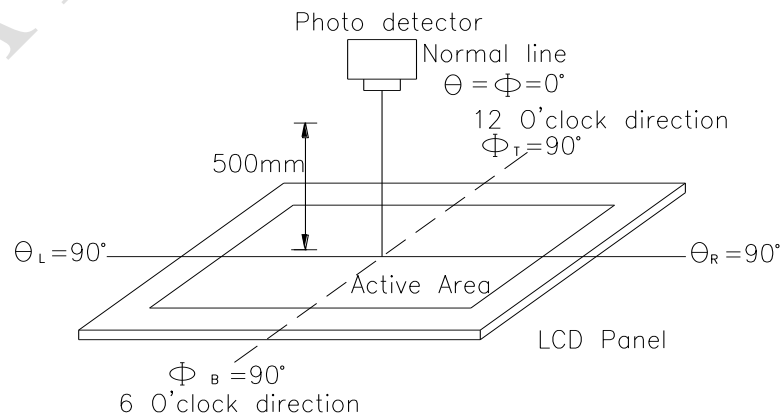
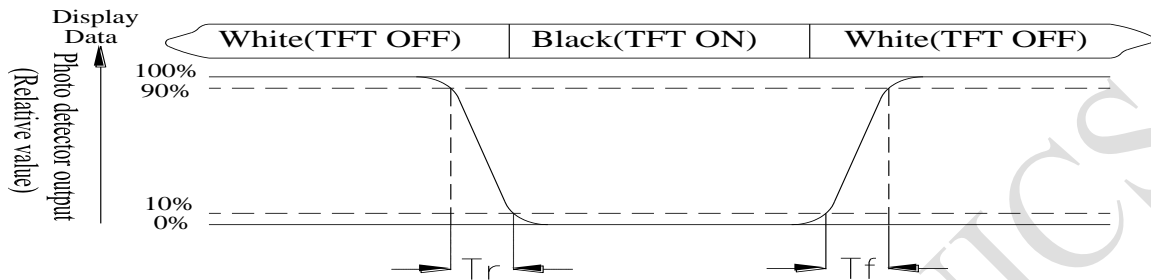

Fig. 11.2. Optical measurement system setup

RAYSTAR OPTRONICS

Note 3: Definition of Response time:

The response time is defined as the LCD optical switching time interval between “White” state and “Black” state. Rise time, T_r , is the time between photo detector output intensity changed from 90% to 10%. And fall time, T_f , is the time between photo detector output intensity changed from 10% to 90%



Note 4: Definition of contrast ratio:

The contrast ratio is defined as the following expression.

$$\text{Contrast ratio (CR)} = \frac{\text{Luminance measured when LCD on the "White" state}}{\text{Luminance measured when LCD on the "Black" state}}$$

Note 5: White $V_i = V_{i50} \pm 1.5V$

Black $V_i = V_{i50} \pm 2.0V$

“±” means that the analog input signal swings in phase with VCOM signal.

“±” means that the analog input signal swings out of phase with VCOM signal.

The 100% transmission is defined as the transmission of LCD panel when all the input terminals of module are electrically opened.

Note 6: Measured at the center area of the panel when all the input terminals of LCD panel are electrically opened.

12. Reliability

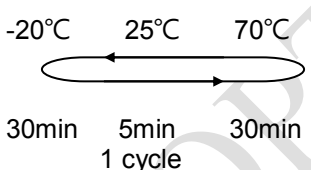
Environmental Test			
Test Item	Content of Test	Test Condition	Note
High Temperature storage	Endurance test applying the high storage temperature for a long time.	80°C 200hrs	2
Low Temperature storage	Endurance test applying the low storage temperature for a long time.	-30°C 200hrs	1,2
High Temperature Operation	Endurance test applying the electric stress (Voltage & Current) and the thermal stress to the element for a long time.	70°C 200hrs	—
Low Temperature Operation	Endurance test applying the electric stress under low temperature for a long time.	-20°C 200hrs	1
High Temperature/ Humidity Operation	The module should be allowed to stand at 60°C,90%RH max	60°C,90%RH 96hrs	1,2
Thermal shock resistance	The sample should be allowed stand the following 10 cycles of operation <div style="text-align: center;">  <p>-20°C 25°C 70°C</p> <p>30min 5min 30min</p> <p>1 cycle</p> </div>	-20°C/70°C 10 cycles	—
Vibration test	Endurance test applying the vibration during transportation and using.	Total fixed amplitude : 1.5mm Vibration Frequency : 10~55Hz One cycle 60 seconds to 3 directions of X, Y, Z for Each 15 minutes	3
Static electricity test	Endurance test applying the electric stress to the terminal.	VS=±600V(contact) ,±800v(air), RS=330Ω CS=150pF 10 times	—

Content of Reliability Test (Wide temperature, -20°C~70°C)

Note1: No dew condensation to be observed.

Note2: The function test shall be conducted after 4 hours storage at the normal Temperature and humidity after remove from the test chamber.

Note3: The packing have to including into the vibration testing.

13.PACKAGE SPECIFICATION

LCM Model	RFP620A-6XW-DNN	LCM 包裝規格書 Packaging Specifications	LCM	Approve	Check	Contact			
Drawing NO.			DATE	初版	版次 Ver	A			
			14'04/16	13'11/14					
1.包裝材料規格表 (Packaging Material) :(per carton)									
NO.	Item	Model	Dimensions	Quantity					
1	成品 (LCM)	RFP620A-6XW-DNN		60					
2	TRAY 盤 (2)	PKCA1XXXXXXXXXXXX0280	315*265mm	30					
3	BP01 內盒(3)Product Box	PK3R1XXXXXXXXXXXX0001	332*280*100mm	6					
4	泡棉(4)Foam	-----	283*230*8mm	6					
5	外紙箱(5)Carton	PK4Q1XXXXXXXXXXXX0000	565*340*320mm	1					
6									
7									
8									
9									
2.單箱數量規格表(Packaging Specifications and Quantity) :									
(1)LCM quantity per box : no per tray 2 x no of tray 5 =10									
(2)Total LCM quantity in carton : quantity per box 10 x no of boxes 6 =60									
特 記 事 項 (REMARK)									
<table border="1" style="width:100%; border-collapse: collapse;"> <tr> <td style="width:30%; padding: 5px;"> 1. Label Specifications : MOEEL: LOT NO : QUANTITY: CHECK: </td> <td style="width:35%;"></td> <td style="width:35%;"></td> </tr> </table>							1. Label Specifications : MOEEL: LOT NO : QUANTITY: CHECK:		
1. Label Specifications : MOEEL: LOT NO : QUANTITY: CHECK:									

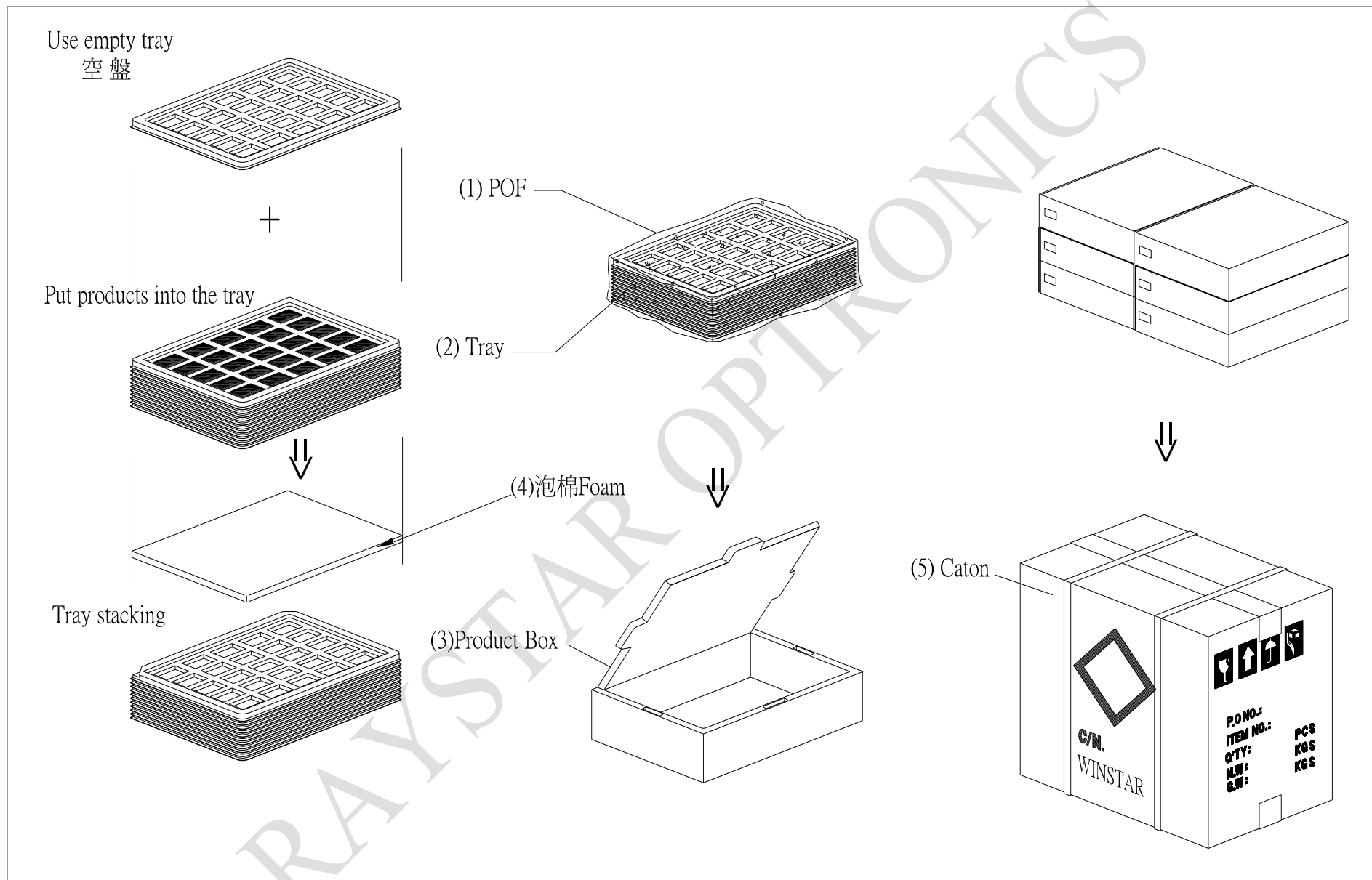

14.Initial Code For Reference

```
void Initial_code()
{
    Write_Command(0xae);
    Write_Data(0xa5);

    Write_Command(0x61);
    Write_Data(0x0f);
    Write_Data(0x04);
    Write_Data(0x02); // or 0Xa5 (older version command)
    Write_Data(0xa5);

    Write_Command(0x62);
    Write_Data(0x00);
    Write_Data(0x3b);
    Write_Data(0x1b);
    Write_Data(0xa5);

    Write_Command(0x63);
    Write_Data(0x05);
    Write_Data(0x0f);
    Write_Data(0xa5);
    Write_Data(0xa5);

    Write_Command(0x24);
    Write_Data(0x01);
    Write_Data(0xa5);
    Write_Data(0xa5);
    Write_Data(0xa5);

    Write_Command(0x22);
    Write_Data(0x02);
    Write_Data(0xa5);
    Write_Data(0xa5);
    Write_Data(0xa5);

    Write_Command(0x91);
    Write_Data(0x00);
    Write_Data(0x21);
    Write_Data(0x23);
    Write_Data(0x24);

    Write_Command(0x92);
    Write_Data(0x27);
    Write_Data(0x28);
    Write_Data(0x29);
    Write_Data(0x2a);
}
```



```
Write_Command(0x93);  
Write_Data(0x2b);  
Write_Data(0x2c);  
Write_Data(0x2d);  
Write_Data(0x2e);
```

```
Write_Command(0x94);  
Write_Data(0x30);  
Write_Data(0x31);  
Write_Data(0x32);  
Write_Data(0x3f);
```

```
Write_Command(0x99);  
Write_Data(0x00);  
Write_Data(0x21);  
Write_Data(0x23);  
Write_Data(0x26);
```

```
Write_Command(0x9a);  
Write_Data(0x27);  
Write_Data(0x28);  
Write_Data(0x29);  
Write_Data(0x2a);
```

```
Write_Command(0x9b);  
Write_Data(0x2b);  
Write_Data(0x2c);  
Write_Data(0x2d);  
Write_Data(0x2e);
```

```
Write_Command(0x9c);  
Write_Data(0x30);  
Write_Data(0x35);  
Write_Data(0x3b);  
Write_Data(0x3f);
```

```
Write_Command(0x12);  
Write_Data(0xa5);
```

```
Write_Command(0x15);  
Write_Data(0xa5);
```

```
}
```

LCM Sample Estimate Feedback Sheet		
Module Number : _____		
1 、 <u>Panel Specification</u> :		
1. Panel Type :	<input type="checkbox"/> Pass	<input type="checkbox"/> NG , _____
2. View Direction :	<input type="checkbox"/> Pass	<input type="checkbox"/> NG , _____
3. Numbers of Dots :	<input type="checkbox"/> Pass	<input type="checkbox"/> NG , _____
4. View Area :	<input type="checkbox"/> Pass	<input type="checkbox"/> NG , _____
5. Active Area :	<input type="checkbox"/> Pass	<input type="checkbox"/> NG , _____
6. Operating Temperature :	<input type="checkbox"/> Pass	<input type="checkbox"/> NG , _____
7. Storage Temperature :	<input type="checkbox"/> Pass	<input type="checkbox"/> NG , _____
8. Others :	_____	
2 、 <u>Mechanical Specification</u> :		
1. PCB Size :	<input type="checkbox"/> Pass	<input type="checkbox"/> NG , _____
2. Frame Size :	<input type="checkbox"/> Pass	<input type="checkbox"/> NG , _____
3. Material of Frame :	<input type="checkbox"/> Pass	<input type="checkbox"/> NG , _____
4. Connector Position :	<input type="checkbox"/> Pass	<input type="checkbox"/> NG , _____
5. Fix Hole Position :	<input type="checkbox"/> Pass	<input type="checkbox"/> NG , _____
6. Backlight Position :	<input type="checkbox"/> Pass	<input type="checkbox"/> NG , _____
7. Thickness of PCB :	<input type="checkbox"/> Pass	<input type="checkbox"/> NG , _____
8. Height of Frame to PCB :	<input type="checkbox"/> Pass	<input type="checkbox"/> NG , _____
9. Height of Module :	<input type="checkbox"/> Pass	<input type="checkbox"/> NG , _____
10. Others :	<input type="checkbox"/> Pass	<input type="checkbox"/> NG , _____
3 、 <u>Relative Hole Size</u> :		
1. Pitch of Connector :	<input type="checkbox"/> Pass	<input type="checkbox"/> NG , _____
2. Hole size of Connector :	<input type="checkbox"/> Pass	<input type="checkbox"/> NG , _____
3. Mounting Hole size :	<input type="checkbox"/> Pass	<input type="checkbox"/> NG , _____
4. Mounting Hole Type :	<input type="checkbox"/> Pass	<input type="checkbox"/> NG , _____
5. Others :	<input type="checkbox"/> Pass	<input type="checkbox"/> NG , _____
4 、 <u>Backlight Specification</u> :		
1. B/L Type :	<input type="checkbox"/> Pass	<input type="checkbox"/> NG , _____
2. B/L Color :	<input type="checkbox"/> Pass	<input type="checkbox"/> NG , _____
3. B/L Driving Voltage (Reference for LED Type) :	<input type="checkbox"/> Pass	<input type="checkbox"/> NG , _____
4. B/L Driving Current :	<input type="checkbox"/> Pass	<input type="checkbox"/> NG , _____
5. Brightness of B/L :	<input type="checkbox"/> Pass	<input type="checkbox"/> NG , _____
6. B/L Solder Method :	<input type="checkbox"/> Pass	<input type="checkbox"/> NG , _____
7. Others :	<input type="checkbox"/> Pass	<input type="checkbox"/> NG , _____

>> **Go to page 2** <<

Module Number : _____		
5 · Electronic Characteristics of Module :		
1.Input Voltage :	<input type="checkbox"/> Pass	<input type="checkbox"/> NG , _____
2.Supply Current :	<input type="checkbox"/> Pass	<input type="checkbox"/> NG , _____
3.Driving Voltage for LCD :	<input type="checkbox"/> Pass	<input type="checkbox"/> NG , _____
4.Contrast for LCD :	<input type="checkbox"/> Pass	<input type="checkbox"/> NG , _____
5.B/L Driving Method :	<input type="checkbox"/> Pass	<input type="checkbox"/> NG , _____
6.Negative Voltage Output :	<input type="checkbox"/> Pass	<input type="checkbox"/> NG , _____
7.Interface Function :	<input type="checkbox"/> Pass	<input type="checkbox"/> NG , _____
8.LCD Uniformity :	<input type="checkbox"/> Pass	<input type="checkbox"/> NG , _____
9.ESD test :	<input type="checkbox"/> Pass	<input type="checkbox"/> NG , _____
10.Others :	<input type="checkbox"/> Pass	<input type="checkbox"/> NG , _____
6 · Summary :		
<p style="text-align: right;"> Sales signature : _____ Customer Signature : _____ Date : / / </p>		

LCM Sample Estimate Feedback Sheet

Module Number : _____

1 、 Panel Specification :

1. Panel Type :	<input type="checkbox"/> Pass	<input type="checkbox"/> NG , _____
2. View Direction :	<input type="checkbox"/> Pass	<input type="checkbox"/> NG , _____
3. Numbers of Dots :	<input type="checkbox"/> Pass	<input type="checkbox"/> NG , _____
4. View Area :	<input type="checkbox"/> Pass	<input type="checkbox"/> NG , _____
5. Active Area :	<input type="checkbox"/> Pass	<input type="checkbox"/> NG , _____
6. Operating Temperature :	<input type="checkbox"/> Pass	<input type="checkbox"/> NG , _____
7. Storage Temperature :	<input type="checkbox"/> Pass	<input type="checkbox"/> NG , _____
8. Others :	_____	

2 、 Mechanical Specification :

1. PCB Size :	<input type="checkbox"/> Pass	<input type="checkbox"/> NG , _____
2. Frame Size :	<input type="checkbox"/> Pass	<input type="checkbox"/> NG , _____
3. Material of Frame :	<input type="checkbox"/> Pass	<input type="checkbox"/> NG , _____
4. Connector Position :	<input type="checkbox"/> Pass	<input type="checkbox"/> NG , _____
5. Fix Hole Position :	<input type="checkbox"/> Pass	<input type="checkbox"/> NG , _____
6. Backlight Position :	<input type="checkbox"/> Pass	<input type="checkbox"/> NG , _____
7. Thickness of PCB :	<input type="checkbox"/> Pass	<input type="checkbox"/> NG , _____
8. Height of Frame to PCB :	<input type="checkbox"/> Pass	<input type="checkbox"/> NG , _____
9. Height of Module :	<input type="checkbox"/> Pass	<input type="checkbox"/> NG , _____
10. Others :	<input type="checkbox"/> Pass	<input type="checkbox"/> NG , _____

3 、 Relative Hole Size :

1. Pitch of Connector :	<input type="checkbox"/> Pass	<input type="checkbox"/> NG , _____
2. Hole size of Connector :	<input type="checkbox"/> Pass	<input type="checkbox"/> NG , _____
3. Mounting Hole size :	<input type="checkbox"/> Pass	<input type="checkbox"/> NG , _____
4. Mounting Hole Type :	<input type="checkbox"/> Pass	<input type="checkbox"/> NG , _____
5. Others :	<input type="checkbox"/> Pass	<input type="checkbox"/> NG , _____

4 、 Backlight Specification :

1. B/L Type :	<input type="checkbox"/> Pass	<input type="checkbox"/> NG , _____
2. B/L Color :	<input type="checkbox"/> Pass	<input type="checkbox"/> NG , _____
3. B/L Driving Voltage (Reference for LED Type) :	<input type="checkbox"/> Pass	<input type="checkbox"/> NG , _____
4. B/L Driving Current :	<input type="checkbox"/> Pass	<input type="checkbox"/> NG , _____
5. Brightness of B/L :	<input type="checkbox"/> Pass	<input type="checkbox"/> NG , _____
6. B/L Solder Method :	<input type="checkbox"/> Pass	<input type="checkbox"/> NG , _____
7. Others :	<input type="checkbox"/> Pass	<input type="checkbox"/> NG , _____

>> **Go to page 2** <<

Module Number : _____

5 · Electronic Characteristics of Module :

1.Input Voltage :	<input type="checkbox"/> Pass	<input type="checkbox"/> NG , _____
2.Supply Current :	<input type="checkbox"/> Pass	<input type="checkbox"/> NG , _____
3.Driving Voltage for LCD :	<input type="checkbox"/> Pass	<input type="checkbox"/> NG , _____
4.Contrast for LCD :	<input type="checkbox"/> Pass	<input type="checkbox"/> NG , _____
5.B/L Driving Method :	<input type="checkbox"/> Pass	<input type="checkbox"/> NG , _____
6.Negative Voltage Output :	<input type="checkbox"/> Pass	<input type="checkbox"/> NG , _____
7.Interface Function :	<input type="checkbox"/> Pass	<input type="checkbox"/> NG , _____
8.LCD Uniformity :	<input type="checkbox"/> Pass	<input type="checkbox"/> NG , _____
9.ESD test :	<input type="checkbox"/> Pass	<input type="checkbox"/> NG , _____
10.Others :	<input type="checkbox"/> Pass	<input type="checkbox"/> NG , _____

6 · Summary :

Sales signature : _____

Customer Signature : _____

Date : / /