

SPECIFICATIONS

CUSTOMER	:	CDE012
SAMPLE CODE	:	SH102600T003-IBC01
MASS PRODUCTION CODE	:	PH102600T003-IBC01
SAMPLE VERSION	:	01
SPECIFICATIONS EDITION	:	005
DRAWING NO. (Ver.)	:	LMD-PH102600T003-IBC01 (Ver.004)
PACKAGING NO. (Ver.)	:	PKG-PH102600T003-IBC01 (Ver.001)

Customer Approved

Date:

Approved	Checked	Designer
<p style="margin: 0;">黃秋源 Oliver Huang</p>	<p style="margin: 0;">石建莊 Stone Shin</p>	<p style="margin: 0;">黃俊清 Ackey Huang</p>

- Preliminary specification for design input
- Specification for sample approval

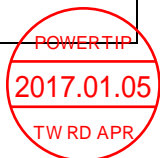

POWERTIP TECH. CORP.

Headquarters: No.8, 6 th Road, Taichung Industrial Park, Taichung, Taiwan 台中市 407 工業區六路 8 號	TEL: 886-4-2355-8168 FAX: 886-4-2355-8166	E-mail: sales@powertip.com.tw Http://www.powertip.com.tw
---	--	--

Contents

1. SPECIFICATIONS

- 1.1 Features
- 1.2 Mechanical Specifications
- 1.3 Absolute Maximum Ratings
- 1.4 DC Electrical Characteristics
- 1.5 Optical Characteristics
- 1.6 Backlight Characteristics
- 1.7 Touch Panel Characteristics

2. MODULE STRUCTURE

- 2.1 Counter Drawing
- 2.2 Interface Pin Description
- 2.3 Timing Characteristics

3. QUALITY ASSURANCE SYSTEM

- 3.1 Quality Assurance Flow Chart
- 3.2 Inspection Specification

4. RELIABILITY TEST

- 4.1 Reliability Test Condition

5. PRECAUTION RELATING PRODUCT HANDLING

- 5.1 Safety
- 5.2 Handling
- 5.3 Storage
- 5.4 Terms of Warranty

Appendix : LCM Drawing
LCM Packaging Specifications

1. SPECIFICATIONS

1.1 Features

Main LCD Panel

Item	Standard Value
Display Type	1024* (R · G · B) * 600 Dots
LCD Type	Normally white
Screen size(inch)	10.1(Diagonal)
Surface treatment	Anti-glare, Hard-Coating(3H)
Color configuration	R.G.B. vertical stripe
Backlight	White LED
Interface	LVDS
ROHS	THIS PRODUCT CONFORMS THE ROHS OF PTC Detail information please refer website : http://www.powertip.com.tw/news.php?area_id_view=1085560481/

1.2 Mechanical Specifications

Item	Standard Value	Unit
Outline Dimension	260.92(W) * 163.48 (L) * 14.98(H)	mm

Note : For detailed information please refer to LCM drawing.

1.3 Absolute Maximum Ratings

Module

Item	Symbol	Min.	Max.	Unit	
Supply Voltage	V _{IN}	-0.3	3.6	V	Logic power supply voltage
		-0.3	24	V	LED Driver Vin
Power Supply Fuse Current Setting	I _{FUSE}	-	1.5	A	Vin from 10%~90%,rise time 500us
Input Signal	V _S	-	3.6	V	LVDS signals
PWM Voltage	V _{PWM}	0.8	5.0	V	PWM Dimming Voltage
Operating Temperature	TOP	-30	85	°C	(1)
Operating Humidity	HOP	10	85	%RH	
Storage Temperature	TST	-30	85	°C	
Storage Humidity	HST	10	85	%RH	

Note:

(1) The storage /operating temperature. Maximum Wet-Bulb should be 39 degree C. There is no condensation on the panel surface.

1.4 DC Electrical Characteristics

System Power Supply

ITEM	SYMBOL	MIN.	TYP.	MAX.	UNIT	CONDITIONS
Input Power Supply Voltage	V_{IN}	3.0	3.3	3.6	V	
Input Power Supply Current	I_{VIN}	-	-	191	mA	Black pattern 60Hz
Input Inrush Current	I_{RUSH}	-	-	1.5	A	0.5ms rise time(10%~90%)
Input Power Voltage Ripple	V_{RPL}	-	-	200	mV	V_{P-P}
REV	VH	2.0	3.3	5.0	V	-
	VL	-	-	0.8	V	-

LED Power Supply

ITEM	SYMBOL	MIN.	TYP.	MAX.	UNIT	CONDITIONS
Input Power Supply Voltage	V_{LED-IN}	8	12	16	V	
Input Power Supply Current	I_{IN}	-	-	546	mA	
EN/PWM	VH	2.0	3.3	5.0	V	
	VL	-	-	0.8	V	

LVDS Signals

ITEM	SYMBOL	MIN.	TYP.	MAX.	UNIT	CONDITIONS
Differential Input High Threshold	V_{th}	-	-	+100	mV	$V_{cm}=+1.2v$
Differential Input High Threshold	V_{tl}	-100	-	-	mV	$V_{cm}=+1.2v$
Magnitude Differential Input Voltage	$ V_{id} $	200	-	600	mV	
Common Mode Voltage	V_{cm}	1.0	1.2	1.4	V	$V_{th} - V_{tl} = 200mV$
Common Mode Voltage Offset	ΔV_{cm}	-50	-	+50	mV	$V_{th} - V_{tl} = 200mV$

1.5 Optical Characteristics

TFT LCD Panel

VDD=3.3V, Ta=25°C

Item	Symbol	Condition	Min.	Typ.	Max.	Unit	-	
Response time	Tr + Tf	Ta = 25°C θX, θY = 0°	-	16	20	ms	Note2	
Viewing angle	Top	θY+	CR ≥ 10	70	80	-	Deg.	Note4
	Bottom	θY-		70	80	-		
	Left	θX-		70	80	-		
	Right	θX+		70	80	-		
Contrast ratio	CR		400	500	-	-	Note3	
Color of CIE Coordinate (With B/L)	White	X	Ta = 25°C θX, θY = 0°	0.255	0.305	0.355	-	Note1
		Y		0.275	0.325	0.375		
	Red	X		0.529	0.579	0.629		
		Y		0.294	0.344	0.394		
	Green	X		0.276	0.326	0.376		
		Y		0.541	0.591	0.641		
	Blue	X		0.109	0.159	0.209		
		Y		0.081	0.131	0.181		
Average Brightness Pattern=white display	IV	-	350	430	-		Note1	
Uniformity	△B	-	70	-	-	%	Note1	

Note1:

1 : $\Delta B = B(\min) / B(\max) \times 100\%$

2 : Measurement Condition for Optical Characteristics:

a : Environment: 25°C ± 5°C / 60 ± 20% R.H , no wind , dark room below 10 Lux at typical lamp current and typical operating frequency.

b : Measurement Distance: 500 ± 50 mm , (θ = 0°)

c : Equipment: TOPCON BM-7 fast , (field 1°) , after 10 minutes operation.

d : The uncertainty of the C.I.E coordinate measurement ± 0.01 , Average Brightness ± 4%

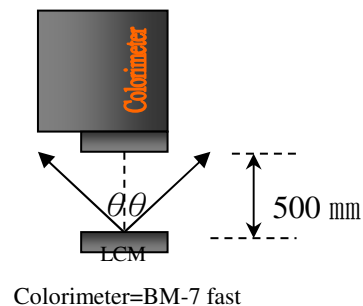
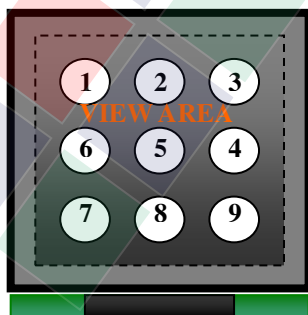

Colorimeter=BM-7 fast

Note2: Definition of response time:

The output signals of photo detector are measured when the input signals are changed from “black” to “white”(falling time) and from “white” to “black”(rising time), respectively. The response time is defined as the time interval between the 10% and 90% of Amplitudes.

Refer to figure as below:

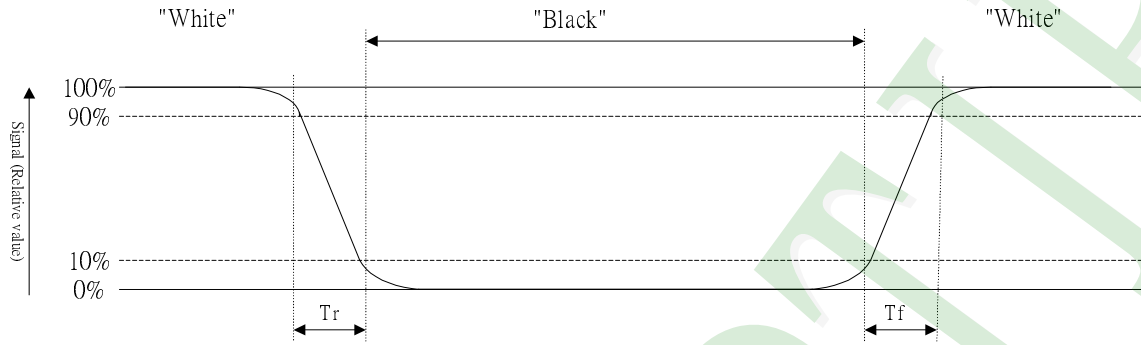

Note3: Definition of contrast ratio:

Contrast ratio is calculated with the following formula

$$\text{Contrast ratio (CR)} = \frac{\text{Photo detector output when LCD is at "White" state}}{\text{Photo detector output when LCD is at "Black" state}}$$

Note4: Definition of viewing angle:

Refer to figure as below:

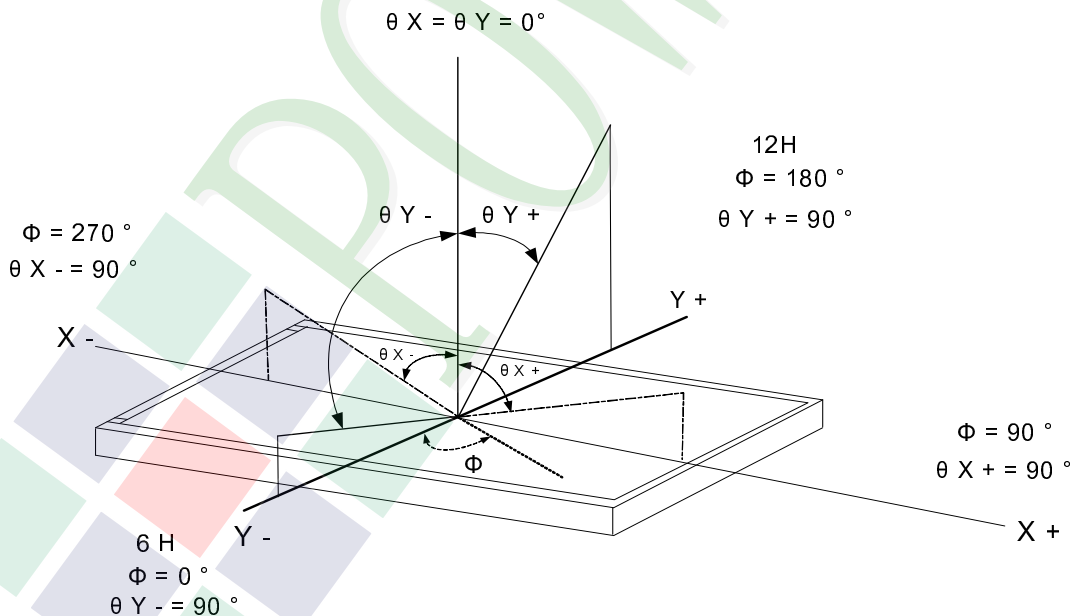

1.6 Backlight Characteristics

Item		UNIT	MIN	TYP	MAX	CONDITION
VIN_LED		V	8	12	16	DUTY=100%
V _{VIN_LED}		mA	-	-	543	-
F _{DIM}		HZ	100	-	1K	-
DUTY		%	5	-	100	-
CTRL	VIH	V	2	3.3	5	-
	VIL	V	0	-	0.8	-
V _{OUT}		V	-	22.4	-	-
I _{OUT}		mA	-	160	-	-
L _T		Hours	50,000	-	-	LED Life Time

Note : The LED life time define as the estimated time to 50% degradation of initial luminous.

1.6 Touch Panel Characteristics

Features

Item	Standard Value
Touch Panel Size	10.1"
Touch type	Transparent Type Projected Capacitive Multi Touch Panel
Input Method	5 Point(use Finger)
IC	ILI2301S + ILIM2VDS
Response Time	≤ 25ms
Light Transparency	85% Min
Surface Hardness	7H(Pencil)

Absolute Maximum Ratings

Item	Symbol	Condition	Min.	Max.	Unit
Operating Temperature	T _{OP}	-	-20	+70	°C
Storage Temperature	T _{ST}	-	-30	+80	°C

2. MODULE STRUCTURE

2.1 Counter Drawing

2.1.1 LCM Mechanical Diagram

* See Appendix

2.1.2 Block Diagram

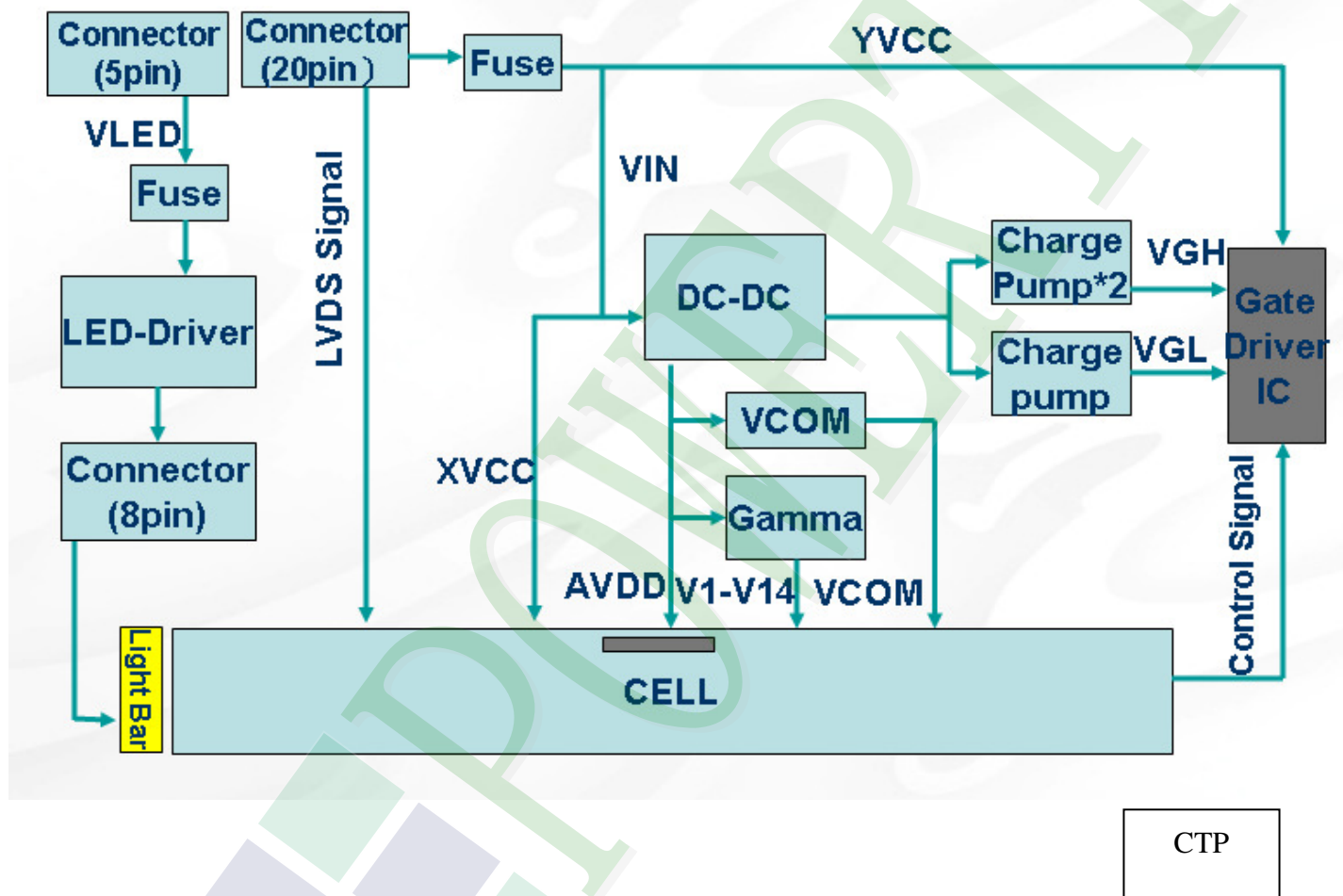

2.2 Interface Pin Description(CN1)

Pin No.	Symbol	Description	
1	VDD	Power Supply.3.3V (typical)	-
2	VDD	Power Supply.3.3V (typical)	-
3	VSS	Ground.	-
4	REV	Reverse Scan selection.	-
5	Rin 1-	-LVDS differential data input..	-
6	Rin 1+	+LVDS differential data input..	-
7	VSS	Ground.	-
8	Rin 2-	-LVDS differential data input.	-
9	Rin 2+	+LVDS differential data input.	-
10	VSS	Ground.	-
11	Rin 3-	-LVDS differential data input.	-
12	Rin 3+	+LVDS differential data input.	-
13	VSS	Ground.	-
14	ClkIN-	-LVDS differential data input.	-
15	ClkIN+	+LVDS differential data input.	-
16	VSS	Ground.	-
17	NC	Not connection.	-
18	NC	Not connection.	-
19	VSS	Ground.	-
20	NC	Not connection.	High Active

Touch Panel Interface Pin(CN3)

Pin No.	Symbol	Description
1	VDD	Supply Voltage :USB 5V.
2	D-	USB differential signal line.
3	D+	USB differential signal line.
4	X	-
5	GND	Ground Connection.
6	X	-

B/L Pin Assignment(CN2)

Pin No.	Symbol	Description	Remarks
1	VCC	Power Supply. 12V(typical).	-
2	GND	Ground.	-
3	EN	3.3V (typical)	-
4	PWM	3.3V (typical)	-
5	NC	Not Connection	-

2.3 Timing Characteristics

DE Synchronization

Parameter	Symbol	Unit	Min.	Typ.	Max.
LVDS Clock Frequency <single>	f_{dck}	MHz	45	51.2	57
H Total Time	T_{hp}	clocks	1,324	1,344	1,364
H Active Time	HA	clocks	1,024	1,024	1,024
H Blanking Time	TH_{BLANK}	clocks	300	320	340
V Total Time	T_{vp}	lines	625	635	645
V Active Time	VA	lines	600	600	600
V Blanking Time	TV_{BLANK}	lines	25	35	45
V Frequency	f_v	Hz	55	60	65

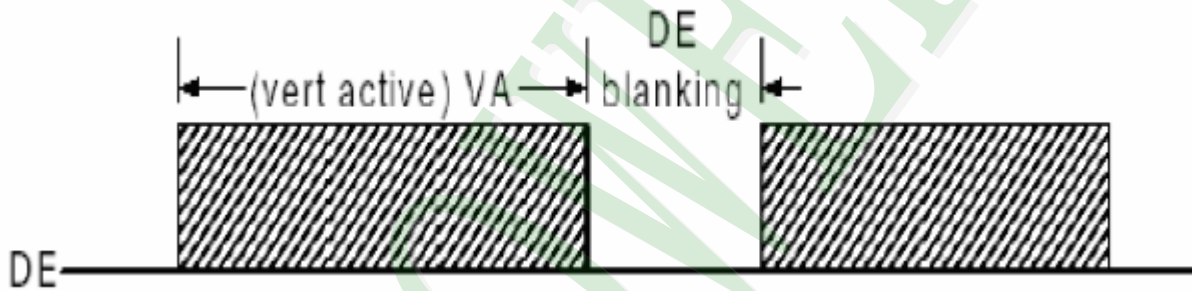

LVDS Data Mapping



3. QUALITY ASSURANCE SYSTEM

3.1 Quality Assurance Flow Chart

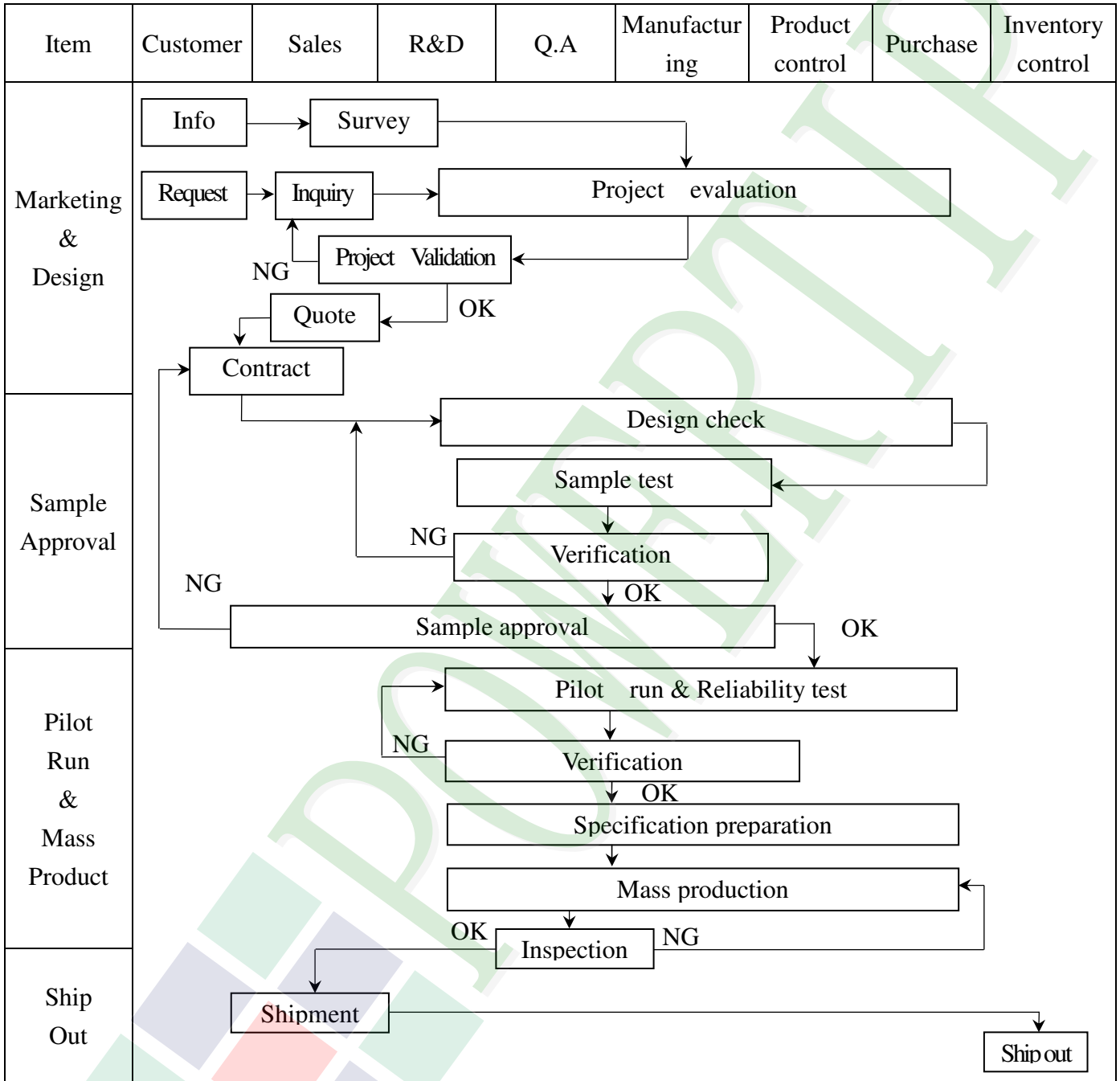

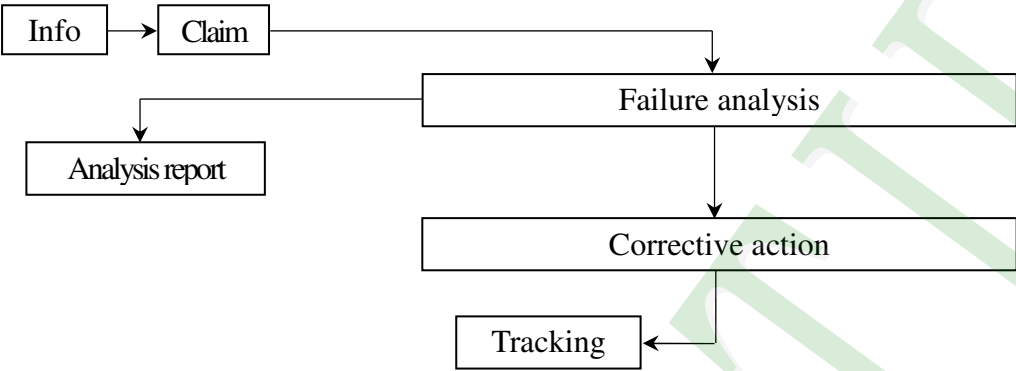
Item	Customer	Sales	R&D	Q.A	Manufacturing	Product control	Purchase	Inventory control
Sales Service	 <pre> graph TD Info[Info] --> Claim[Claim] Claim --> Failure[Failure analysis] Failure --> Report[Analysis report] Failure --> Action[Corrective action] Action --> Tracking[Tracking] </pre>							
Q.A Activity	1. ISO 9001 Maintenance Activities 3. Equipment calibration 5. Standardization Management				2. Process improvement proposal 4. Education And Training Activities			

3.2. Inspection Specification

◆Scope : The document shall be applied to TFT-LCD Module for 3.5" ~10.1" (Ver.B01).

◆Inspection Standard : MIL-STD-105E Table Normal Inspection Single Sampling Level II.

◆Equipment : Gauge 、 MIL-STD 、 Powertip Tester 、 Sample

◆Defect Level : Major Defect AQL : 0.4 ; Minor Defect AQL : 1.5

◆OUT Going Defect Level : Sampling.

◆Standard of the product appearance test :

a. Manner of appearance test :

(1). The test best be under 20W×2 fluorescent light , and distance of view must be at 30 cm.

(2). The test direction is base on about around 45° of vertical line.

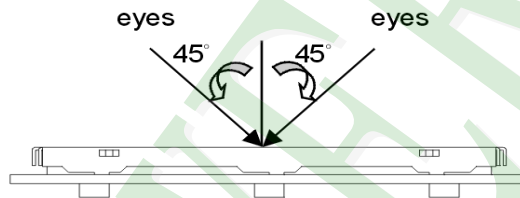

(3). Definition of area.

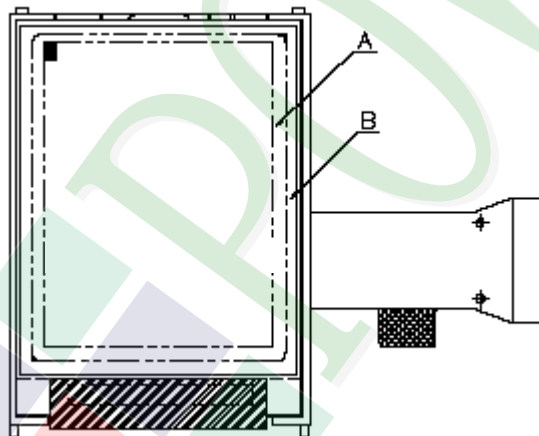

A area : viewing area

B area : Outside of viewing area

(4). Standard of inspection : (Unit : mm)

◆Specification For TFT-LCD Module 3. 5" ~10. 1" :

(Ver.B01)

NO	Item	Criterion	Level												
01	Product condition	1. 1The part number is inconsistent with work order of production.	Major												
		1. 2 Mixed product types.	Major												
		1. 3 Assembled in inverse direction.	Major												
02	Quantity	2. 1The quantity is inconsistent with work order of production.	Major												
03	Outline dimension	3. 1 Product dimension and structure must conform to structure diagram.	Major												
04	Electrical Testing	4. 1 Missing line character and icon.	Major												
		4. 2 No function or no display.	Major												
		4. 3 Display malfunction.	Major												
		4. 4 LCD viewing angle defect.	Major												
		4. 5 Current consumption exceeds product specifications.	Major												
05	Dot defect (Bright dot 、 Dark dot) On -display	<table border="1" data-bbox="561 1323 1273 1630"> <thead> <tr> <th></th> <th>Item</th> <th>Acceptance (Q'ty)</th> </tr> </thead> <tbody> <tr> <td rowspan="4">Dot Defect</td> <td>Bright Dot</td> <td>≤ 4</td> </tr> <tr> <td>Dark Dot</td> <td>≤ 5</td> </tr> <tr> <td>Joint Dot</td> <td>≤ 3</td> </tr> <tr> <td>Total</td> <td>≤ 7</td> </tr> </tbody> </table> <p>5. 1 Inspection pattern : full white , full black , Red , Green and blue screens. 5. 2 It is defined as dot defect if defect area $> 1/2$ dot. 5. 3 The distance between two dot defect ≥ 5 mm. 5. 4 Bright dot that can be seen through 5% ND filter.</p>		Item	Acceptance (Q'ty)	Dot Defect	Bright Dot	≤ 4	Dark Dot	≤ 5	Joint Dot	≤ 3	Total	≤ 7	Minor
	Item	Acceptance (Q'ty)													
Dot Defect	Bright Dot	≤ 4													
	Dark Dot	≤ 5													
	Joint Dot	≤ 3													
	Total	≤ 7													

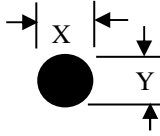
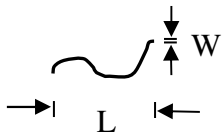
NO	Item	Criterion	Level																																						
06	<p>Black or white dot、scratch、contamination</p> <p>Round type</p>  <p>$\Phi = (x + y) / 2$</p> <p>Line type</p> 	<p>6. 1 Round type (Non-display or display) :</p> <table border="1" data-bbox="529 439 1308 855"> <thead> <tr> <th rowspan="2">Dimension (diameter : Φ)</th> <th colspan="2">Acceptance (Q'ty)</th> </tr> <tr> <th>A area</th> <th>B area</th> </tr> </thead> <tbody> <tr> <td>$\Phi \leq 0.25$</td> <td>Ignore</td> <td rowspan="3">Ignore</td> </tr> <tr> <td>$0.25 < \Phi \leq 0.50$</td> <td>5</td> </tr> <tr> <td>$\Phi > 0.50$</td> <td>0</td> </tr> <tr> <td>Total</td> <td>5</td> <td></td> </tr> </tbody> </table> <p>6. 2 Line type(Non-display or display) :</p> <table border="1" data-bbox="504 974 1337 1442"> <thead> <tr> <th rowspan="2">Length (L)</th> <th rowspan="2">Width (W)</th> <th colspan="2">Acceptance (Q'ty)</th> </tr> <tr> <th>A area</th> <th>B area</th> </tr> </thead> <tbody> <tr> <td>---</td> <td>$W \leq 0.03$</td> <td>Ignore</td> <td rowspan="4">Ignore</td> </tr> <tr> <td>$L \leq 10.0$</td> <td>$0.03 < W \leq 0.05$</td> <td>4</td> </tr> <tr> <td>$L \leq 5.0$</td> <td>$0.05 < W \leq 0.10$</td> <td>2</td> </tr> <tr> <td>---</td> <td>$W > 0.10$</td> <td>As round type</td> </tr> <tr> <td>Total</td> <td></td> <td>5</td> <td></td> </tr> </tbody> </table>	Dimension (diameter : Φ)	Acceptance (Q'ty)		A area	B area	$\Phi \leq 0.25$	Ignore	Ignore	$0.25 < \Phi \leq 0.50$	5	$\Phi > 0.50$	0	Total	5		Length (L)	Width (W)	Acceptance (Q'ty)		A area	B area	---	$W \leq 0.03$	Ignore	Ignore	$L \leq 10.0$	$0.03 < W \leq 0.05$	4	$L \leq 5.0$	$0.05 < W \leq 0.10$	2	---	$W > 0.10$	As round type	Total		5		Minor
Dimension (diameter : Φ)	Acceptance (Q'ty)																																								
	A area	B area																																							
$\Phi \leq 0.25$	Ignore	Ignore																																							
$0.25 < \Phi \leq 0.50$	5																																								
$\Phi > 0.50$	0																																								
Total	5																																								
Length (L)	Width (W)	Acceptance (Q'ty)																																							
		A area	B area																																						
---	$W \leq 0.03$	Ignore	Ignore																																						
$L \leq 10.0$	$0.03 < W \leq 0.05$	4																																							
$L \leq 5.0$	$0.05 < W \leq 0.10$	2																																							
---	$W > 0.10$	As round type																																							
Total		5																																							
07	<p>Polarizer Bubble</p>	<table border="1" data-bbox="497 1512 1343 1933"> <thead> <tr> <th rowspan="2">Dimension (diameter : Φ)</th> <th colspan="2">Acceptance (Q'ty)</th> </tr> <tr> <th>A area</th> <th>B area</th> </tr> </thead> <tbody> <tr> <td>$\Phi \leq 0.25$</td> <td>Ignore</td> <td rowspan="5">Ignore</td> </tr> <tr> <td>$0.25 < \Phi \leq 0.50$</td> <td>4</td> </tr> <tr> <td>$0.50 < \Phi \leq 0.80$</td> <td>1</td> </tr> <tr> <td>$\Phi > 0.80$</td> <td>0</td> </tr> <tr> <td>Total</td> <td>5</td> </tr> </tbody> </table>	Dimension (diameter : Φ)	Acceptance (Q'ty)		A area	B area	$\Phi \leq 0.25$	Ignore	Ignore	$0.25 < \Phi \leq 0.50$	4	$0.50 < \Phi \leq 0.80$	1	$\Phi > 0.80$	0	Total	5	Minor																						
Dimension (diameter : Φ)	Acceptance (Q'ty)																																								
	A area	B area																																							
$\Phi \leq 0.25$	Ignore	Ignore																																							
$0.25 < \Phi \leq 0.50$	4																																								
$0.50 < \Phi \leq 0.80$	1																																								
$\Phi > 0.80$	0																																								
Total	5																																								

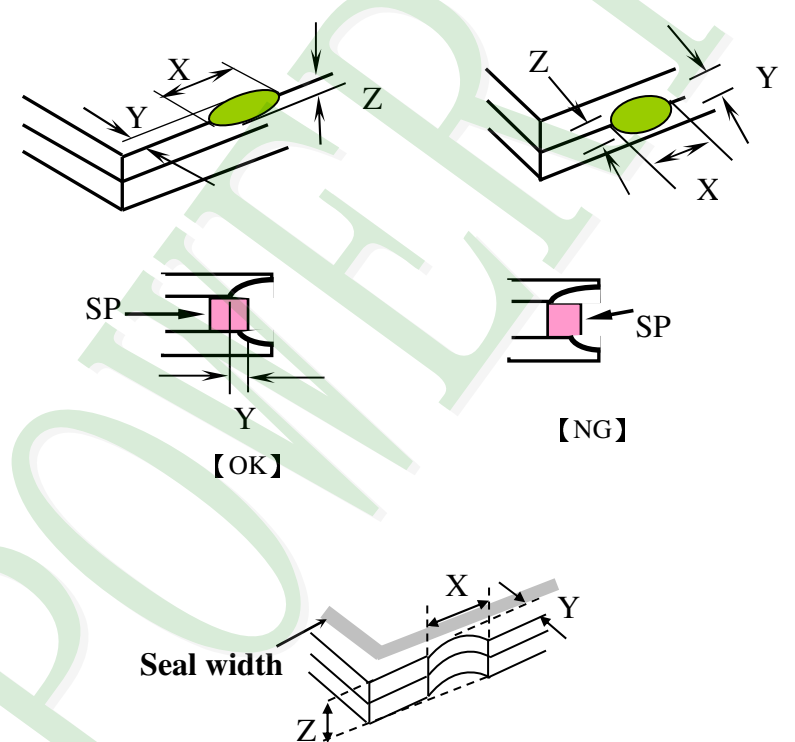
NO	Item	Criterion	Level						
08	The crack of glass	<p>Symbols :</p> <p>X : The length of crack Z : The thickness of crack t : The thickness of glass</p> <p>Y : The width of crack. W : terminal length a : LCD side length</p>	Minor						
		<p>8.1 General glass chip :</p> <p>8.1.1 Chip on panel surface and crack between panels:</p>  <table border="1" data-bbox="539 1585 1353 1881"> <thead> <tr> <th>X</th> <th>Y</th> <th>Z</th> </tr> </thead> <tbody> <tr> <td>$\leq a$</td> <td>Crack can't enter viewing area</td> <td>$\leq 1/2 t$</td> </tr> <tr> <td>$\leq a$</td> <td>Crack can't exceed the half of SP width.</td> <td>$1/2 t < Z \leq 2 t$</td> </tr> </tbody> </table>		X	Y	Z	$\leq a$	Crack can't enter viewing area	$\leq 1/2 t$
X	Y	Z							
$\leq a$	Crack can't enter viewing area	$\leq 1/2 t$							
$\leq a$	Crack can't exceed the half of SP width.	$1/2 t < Z \leq 2 t$							

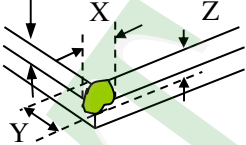
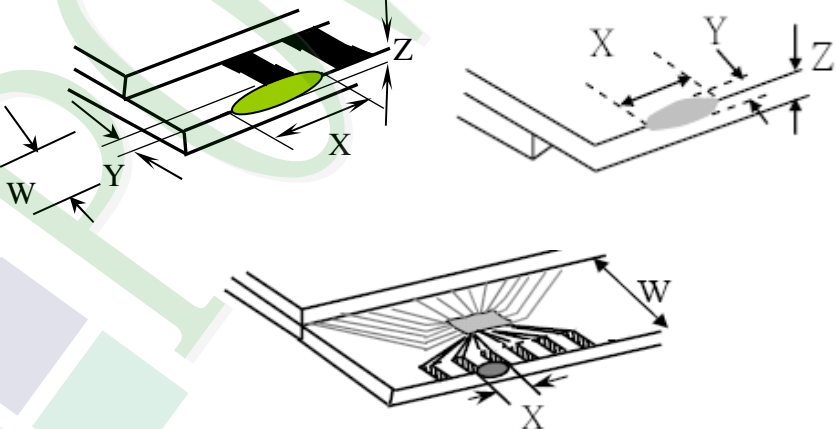
NO	Item	Criterion	Level										
08	The crack of glass	<p>Symbols :</p> <p>X : The length of crack Z : The thickness of crack t : The thickness of glass</p> <p>Y : The width of crack. W : terminal length a : LCD side length</p> <hr/> <p>8.1.2 Corner crack :</p>  <table border="1" data-bbox="523 779 1337 1070"> <thead> <tr> <th>X</th> <th>Y</th> <th>Z</th> </tr> </thead> <tbody> <tr> <td>$\leq 1/5 a$</td> <td>Crack can't enter viewing area</td> <td>$Z \leq 1/2 t$</td> </tr> <tr> <td>$\leq 1/5 a$</td> <td>Crack can't exceed the half of SP width.</td> <td>$1/2 t < Z \leq 2 t$</td> </tr> </tbody> </table>	X	Y	Z	$\leq 1/5 a$	Crack can't enter viewing area	$Z \leq 1/2 t$	$\leq 1/5 a$	Crack can't exceed the half of SP width.	$1/2 t < Z \leq 2 t$		
		X	Y	Z									
$\leq 1/5 a$	Crack can't enter viewing area	$Z \leq 1/2 t$											
$\leq 1/5 a$	Crack can't exceed the half of SP width.	$1/2 t < Z \leq 2 t$											
<p>8.2 Protrusion over terminal :</p> <p>8.2.1 Chip on electrode pad :</p>  <table border="1" data-bbox="561 1711 1347 1886"> <thead> <tr> <th></th> <th>X</th> <th>Y</th> <th>Z</th> </tr> </thead> <tbody> <tr> <td>Front</td> <td>$\leq a$</td> <td>$\leq 1/2 W$</td> <td>$\leq t$</td> </tr> <tr> <td>Back</td> <td>$\leq a$</td> <td>$\leq W$</td> <td>$\leq 1/2 t$</td> </tr> </tbody> </table>		X	Y	Z	Front	$\leq a$	$\leq 1/2 W$	$\leq t$	Back	$\leq a$	$\leq W$	$\leq 1/2 t$	Minor
	X	Y	Z										
Front	$\leq a$	$\leq 1/2 W$	$\leq t$										
Back	$\leq a$	$\leq W$	$\leq 1/2 t$										

◆Specification For TFT-LCD Module 3.5" ~10" :

(Ver.B01)

NO	Item	Criterion	Level
09	Backlight elements	9. 1 Backlight can't work normally.	Major
		9. 2 Backlight doesn't light or color is wrong.	Major
		9. 3 Illumination source flickers when lit.	Major
10	General appearance	10. 1 Pin type 、 quantity 、 dimension must match type in structure diagram.	Major
		10. 2 No short circuits in components on PCB or FPC .	Major
		10. 3 Parts on PCB or FPC must be the same as on the production characteristic chart .There should be no wrong parts , missing parts or excess parts.	Major
		10. 4 Product packaging must the same as specified on packaging specification sheet.	Minor
		10. 5 The folding and peeled off in polarizer are not acceptable.	Minor
		10. 6 The PCB or FPC between B/L assembled distance(PCB or FPC) is ≤ 1.5 mm.	Minor

5. PRECAUTION RELATING PRODUCT HANDLING

5.1 SAFETY

- 5.1.1 If the LCD panel breaks , be careful not to get the liquid crystal to touch your skin.
- 5.1.2 If the liquid crystal touches your skin or clothes , please wash it off immediately by using soap and water.

5.2 HANDLING

- 5.2.1 Avoid any strong mechanical shock which can break the glass.
- 5.2.2 Avoid static electricity which can damage the CMOS LSI—When working with the module , be sure to ground your body and any electrical equipment you may be using.
- 5.2.3 Do not remove the panel or frame from the module.
- 5.2.4 The polarizing plate of the display is very fragile. So , please handle it very carefully, do not touch , push or rub the exposed polarizing with anything harder than an HB pencil lead (glass , tweezers , etc.)
- 5.2.5 Do not wipe the polarizing plate with a dry cloth , as it may easily scratch the surface of plate.
- 5.2.6 Do not touch the display area with bare hands , this will stain the display area.
- 5.2.7 Do not use ketonics solvent & aromatic solvent. Use with a soft cloth soaked with a cleaning naphtha solvent.
- 5.2.8 To control temperature and time of soldering is $320 \pm 10^{\circ}\text{C}$ and 3-5 sec.
- 5.2.9 To avoid liquid (include organic solvent) stained on LCM

5.3 STORAGE

- 5.3.1 Store the panel or module in a dark place where the temperature is $25^{\circ}\text{C} \pm 5^{\circ}\text{C}$ and the humidity is below 65% RH.
- 5.3.2 Do not place the module near organics solvents or corrosive gases.
- 5.3.3 Do not crush , shake , or jolt the module.

5.4 TERMS OF WARRANTY

- 5.4.1 Applicable warrant period
The period is within thirteen months since the date of shipping out under normal using and storage conditions.
- 5.4.2 Unaccepted responsibility
This product has been manufactured to your company's specification as a part for use in your company's general electronic products. It is guaranteed to perform according to delivery specifications. For any other use apart from general electronic equipment, we cannot take responsibility if the product is used in nuclear power control equipment, aerospace equipment , fire and security systems or any other applications in which there is a direct risk to human life and where extremely high levels of reliability are required.

Ver.001

LCM包裝規格書

LCM Packaging Specifications
(For Tray)

Documents NO. PKG-PH102600T003-IBC01

Approve	Check	Contact
Oliver	Sam	Stone

1. 包裝材料規格表 (Packaging Material) : (per carton)

No.	Item	Model	Dimensions (mm)	1Pcs Weight	Quantity	Total Weight
1	成品 (LCD)	PH102600T003-IBC01	260.92 X 163.48	0.598	18	10.764
2	多層薄膜(1)POF	OTFILM0BA03ABA	—————	—————	3	—————
3	TRAY 盤 (2)Tray	TY00000000321	517 X 377 X 21.8	0.2	9	1.8
4	內盒(3)Product Box	BX00000000071	558 X 393 X 68	0.6	3	1.8
5	保利龍板(4)Polylon board	OTPLB00PL08ABA	550 X 393 X 20	0.0284	2	0.0568
6	外紙箱(5)Carton	BX57041027CCBA	570 X 410 X 265	1.4208	1	1.4208
7	舒美墊(6)EPE	OTFOAMEP0004BA	333X 218 X 15	0.027	3	0.081
8						
9						

2. 一整箱總重量 (Total LCD Weight in carton) : 17.83 Kg±10%

3. 單箱數量規格表 (Packaging Specifications and Quantity) :

(1)LCD quantity per box : no per tray	2	x no of tray	3	=	6
(2)Total LCD quantity in carton : quantity per box	8	x no of boxes	3	=	18

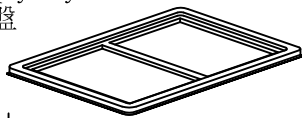
Use empty tray
空盤

+

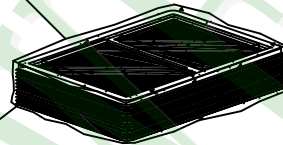
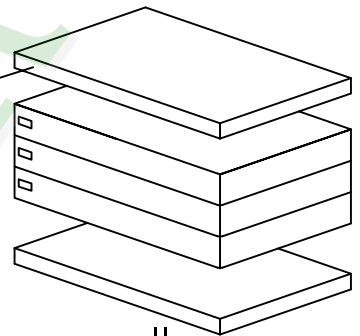
(1)多層薄膜
POF(4)保利龍板
Polylon board

Put products into the tray

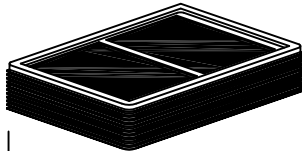
(2)TRAY 盤
Tray

↓

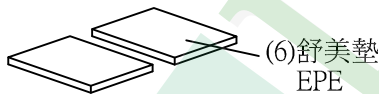
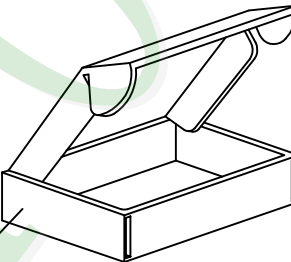
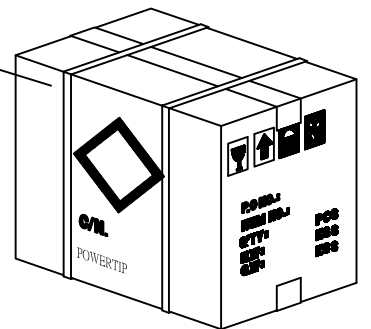
(6)舒美墊
EPE(3)內盒
Product Box(5)外紙箱
Carton

Tray stacking

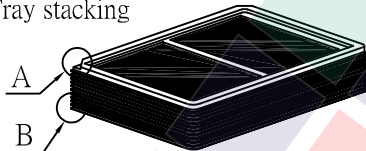

特 記 事 項 (REMARK)

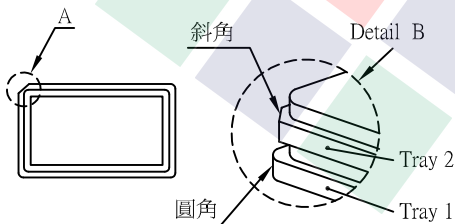

5. 最上層產品上放置EPE(舒美墊)

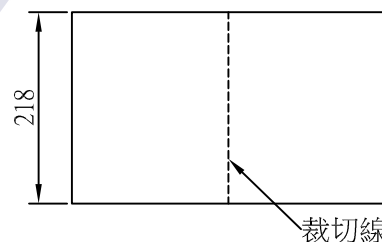
4. TRAY盤相疊時,需旋轉180度,請詳見B視圖
Rotate tray 180 degrees and place on top of stack.
Check the tray stack using Fig. B.