

Display Elektronik GmbH

DATA SHEET

TFT- MODULE

**DEM 640480D TMH-PW-N
(A-TOUCH)**

5,7" TFT with Touch-Panel

Product Specification

Ver.: 2

15.12.2010

Rev.	Date	Contents	Written	Approved
0	28.04.2010	Preliminary Specification	KC	MH
1	01.06.2010	Correction page10: 3.3.2clock and Data Waveform	KC	MH
2	15.12.2010	Add RoHS Compliance	KC	MH

Special Notes

Note1.	
Note2.	
Note3.	
Note4.	
Note5.	

Contents

1	General Description and Features	4
1.1	Features	4
1.2	LCD Module.....	4
2	Mechanical Information.....	4
3	Electrical Specifications.....	5
3.1	Absolute Max. Ratings.....	5
3.2	Electrical Characteristics.....	7
3.3	AC Timing Characteristic of The LCD	8
3.4	Back-Light Unit.....	11
4	Optical Characteristics.....	11
4.1	Optical characteristic of the LCD	11
5	Input Terminal Pin Assignment	14
5.1	Pin Assignment	14
5.2	Back-light Unit (BLU).....	14
5.3	Block Diagram	15
5.4	Basic Display Color and Gray Scale	16
6	Touch Screen Panel	17
6.1	Electrical Characteristics.....	17
6.2	Mechanical & Reliability Characteristics	17
7	Reliability Condition	18
8	Dimensional Outlines	19

1 General Description and Features

DEM 640480D TMH-PW-N(A-TOUCH) is a transmissive type color active matrix TFT (Thin Film Transistor) liquid crystal display (LCD) that uses amorphous silicon TFT as a switching device. This model is composed of a TFT-LCD module, a driver circuit and a back-light unit and touch screen panel (TSP). Graphics and texts can be displayed on a VGA 640 (W) x 3 x 480 (H) dots with 262,144 colors by supplying 18 bits data signal (6bits/each color). The following table described the features of DEM 640480D TMH-PW-N(A-TOUCH).

1.1 Features

- ◆ Transmissive and back-light with 30 LEDs are available
- ◆ TN (Twisted Nematic) mode.
- ◆ Digital RGB (6bits/color) data transfer
- ◆ Clock signal: latching data at the falling edge.
- ◆ RoHS Compliance
- ◆ Integrated 4-Wire-Resistive Touch-Panel

1.2 LCD Module

Item	Specification	Unit
Screen Size	5.7 inches	Diagonal
Display Resolution	640 (H) x 480 (V)	Pixel
Active Area	115.20 (H) x 86.40 (V)	mm
Outline Dimension	144.00 (H) x 104.60 (V) x 14.5 (T)	mm
Display Mode	Normally white mode/ Transmissive/ Wide view	--
Pixel Arrangement	R,G,B Vertical Tripe	--
Pixel size	181.5 x 181.5	um
Display Color	262K Colors	--
Viewing Direction	6 o'clock	--
Input Interface	LVDS (6bits/color) Data Transfer	--

2 Mechanical Information

Item	Min.	Typ.	Max.	Unit	Note
Module Size	Horizontal (H)	--	144.00	--	mm (1)
	Vertical (V)	--	104.60	--	mm (1)
	Thickness (T)	--	14.5	--	mm (1)
Weight	--	TBD	--	g	--

Note (1) Excluding backlight cables. . Refer to the Outline Dimension Drawing as attached.

3 Electrical Specifications

3.1 Absolute Max. Ratings

3.1.1 Absolute Ratings of Environment

If the operating condition exceeds the following absolute maximum ratings, the TFT LCD module may be damaged permanently.

(Ta=25±2°C, V_{SS}=GND=0)

Item	Symbol	Min.	Max.	Unit	Note
Storage temperature	T _{STG}	-30	80	°C	(1)
Operating temperature	T _{OPR}	-20	70	°C	(1,2,3)

Note (1) 95 % RH Max. (40 °C ≥ Ta). Maximum wet-bulb temperature at 39 °C or less. (Ta > 40 °C) No condensation.

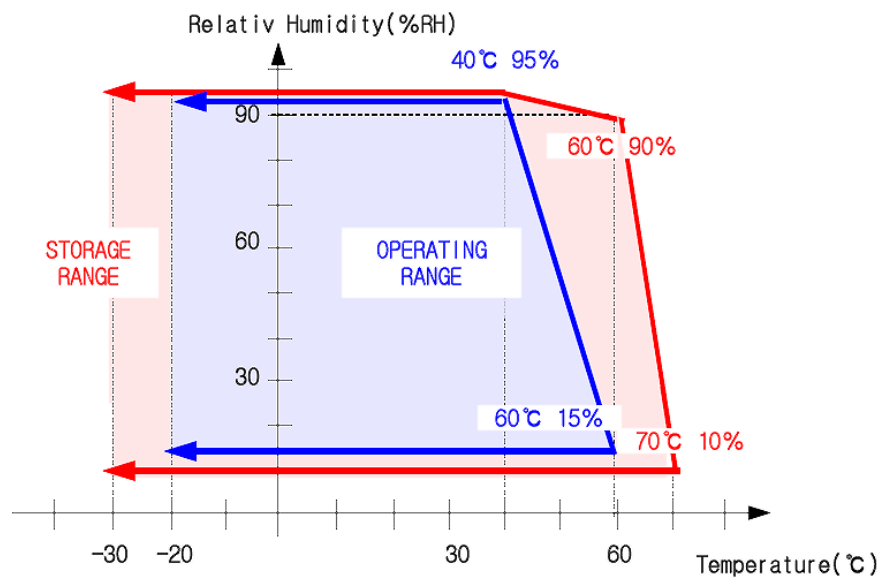

Note (2) In case of below 0°, the response time of liquid crystal (LC) becomes slower and the color of panel becomes darker than normal one. Level of retardation depends on temperature, because of LC's character

Note (3) Only operation is guaranteed at operating temperature. Contrast, response time, another display quality are evaluated at +25°C.

3.1.2 Electrical Absolute Maximum Ratings

(V_{SS}=GND=0)

Parameter	Symbol	Min.	Max.	Unit	Remark
Power supply voltage	V _{CC}	-0.3	5.0	V	
Signal input voltage	R0-R5,G0-G5, B0-B5,DCLK,DE	-0.3	V _{CC} +0.3	V	--
Permissive input ripple voltage	V _{RF}	--	100	mVp-p	V _{CC} = +3.3V

Display On/Off Sequence :

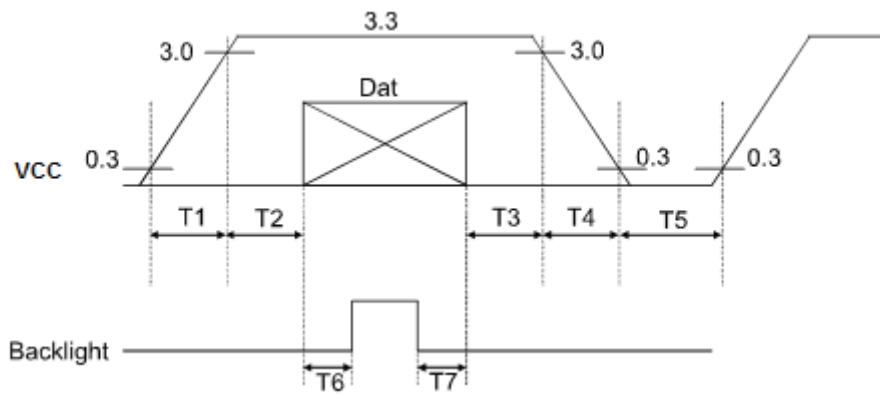

Data: DCLK, R0 ~ R5, G0 ~ G5, B0 ~ B5, DE

T1≤10ms, 50ms≤T2, 0<T3≤50ms, 0<T4≤10ms, 1s≤T5, 200ms≤T6, 200ms≤T7

3.2 Electrical Characteristics

3.2.1 DC Electrical Characteristics of the TFT LCD

(Ta=25±2°C, V_{SS}=GND=0)

Item	Symbol	Min.	Typ.	Max.	Unit	Remark	
Power supply	VCC	3.0	3.3	3.6	V	Note 1	
Input Voltage for logic	H Level	V _{IH}	0.7V _{DD}	-	V _{DD}	V	
	L Level	V _{IL}	0	-	0.3V _{DD}	V	
Power Supply current	ICC		(120)	TBD	mA	Note 2	

Note1: Vcc-dip conditions
Vcc-dip conditions should also follow the Vcc-turn-on conditions
T_d ≤ 10ms

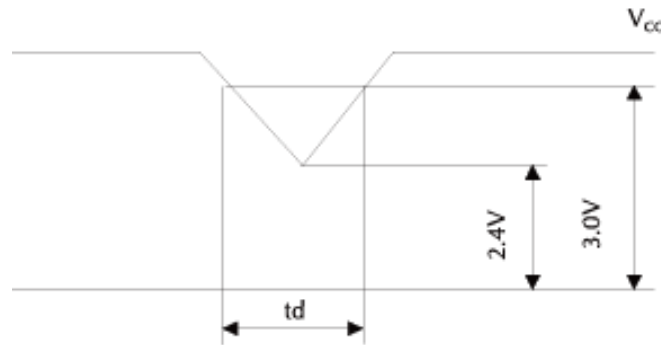

Note2: f_v =60Hz , Ta=25°C , Display pattern : 64 Gray pattern

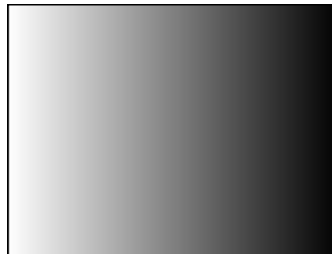

3.3 AC Timing Characteristic of The LCD

3.3.1 Timing Condition

Parameter	Symbol	Min.	Typ.	Max.	Unit.	Remark
CLK frequency	F_{CPH}	--	25.175	--	MHZ	
CLK period	T_{CPH}	--	39.7	--	ns	
CLK pulse duty	T_{CWH}	40	50	60	%	
HS period	T_H	--	800	--	T_{CPH}	
HS pulse width	T_{WH}	5	30	--	T_{CPH}	
HS-DEN time	T_{HS}	112	144	175	T_{CPH}	
DEN pulse width	T_{EP}	--	640	--	T_{CPH}	
VS pulse width	T_{WV}	1	3	5	T_H	
VS-DEN time	T_{STV}	--	35	--	T_H	
VS period	T_V	--	525	--	T_H	

Note : When SYNC mode is used, 1st data start from 144th CLK after HS falling (when $STHD[5:0]=00000$)

Parameter	Symbol	Min.	Typ.	Max.	Unit.	Remark
OEV pulse width	T_{CVE}	--	100	--	T_{CPH}	
CKV pulse width	T_{CKV}	--	96	--	T_{CPH}	
HS-CKV time	T_1	--	52	--	T_{CPH}	
HS-OEV tim	T_2	--	8	--	T_{CPH}	
HS-POL time	T_3	--	72	--	T_{CPH}	
STV setup time	T_{SUV}	--	46	--	T_{CPH}	
STV pulse width	T_{WSTV}	--	1	--	T_H	

3.3.2 Clock and Data input waveforms

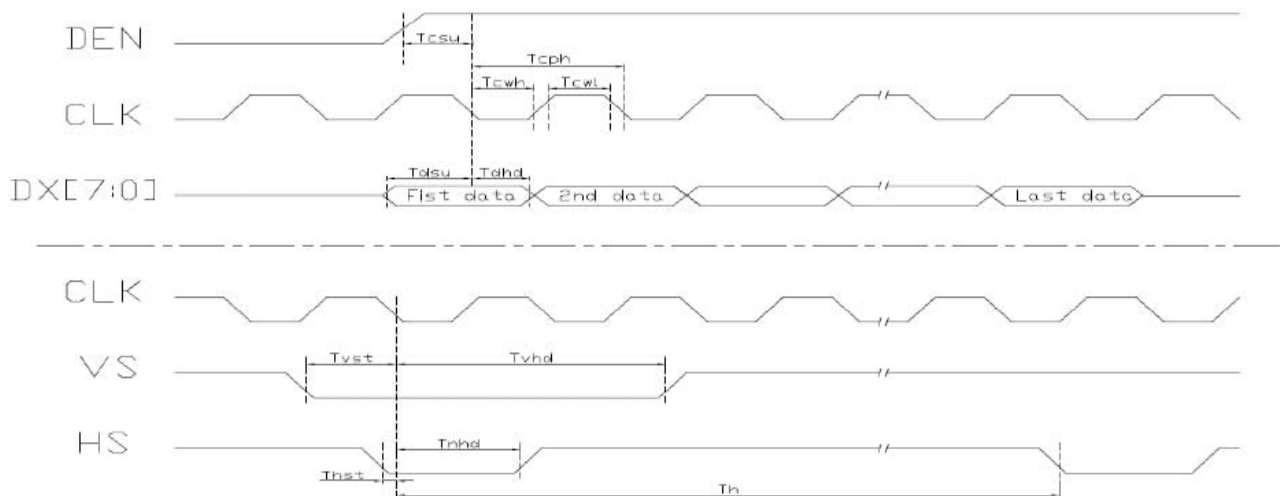

3.3.3 Data input format for parallel RGB Mode

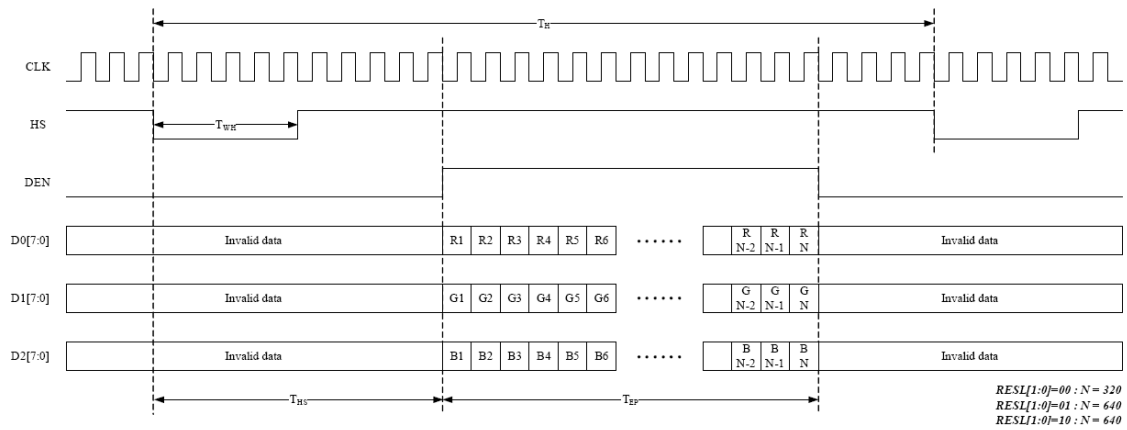

3.3.4 Digital RGB mode Horizontal timing for RESL[1:0]=10

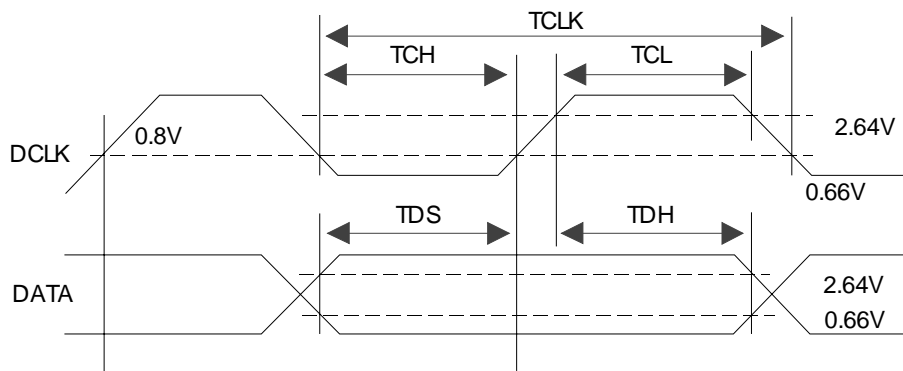
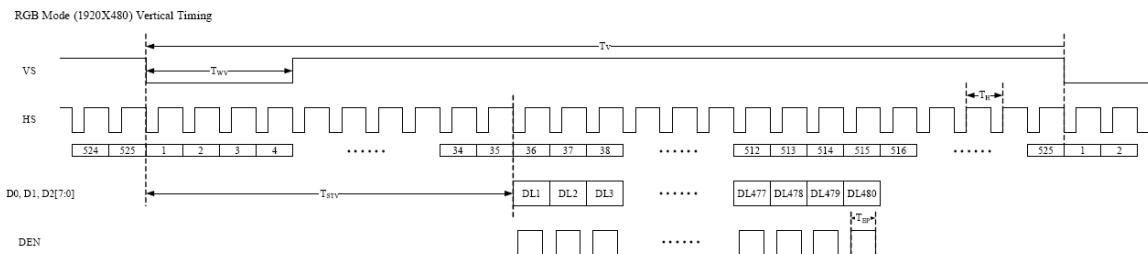

3.3.5 LVDS Timing Condition

t_{RCP}	CLK OUT Period	11.76	T	50.0	ns
t_{RCH}	CLK OUT High Time		$4T/7$		ns
t_{RCL}	CLK OUT Low Time		$3T/7$		ns
t_{RCD}	RCLK+/- to CLK OUT Delay		$5T/7$		ns
t_{RS}	TTL Data Setup to CLK OUT	$3T/7-2.5$			ns
t_{RH}	TTL Data Hold from CLK OUT	$4T/7-3.5$			ns
t_{TLH}	TTL Low to High Transition Time		3.0	5.0	ns
t_{THL}	TTL High to Low Transition Time		3.0	5.0	ns
t_{RIP1}	Input Data Position 0 (T=11.76ns)	-0.4	0.0	0.4	ns
t_{RIP0}	Input Data Position 1 (T=11.76ns)	$T/7-0.4$	$T/7$	$T/7+0.4$	ns
t_{RIP6}	Input Data Position 2 (T=11.76ns)	$2T/7-0.4$	$2T/7$	$2T/7+0.4$	ns
t_{RIP5}	Input Data Position 3 (T=11.76ns)	$3T/7-0.4$	$3T/7$	$3T/7+0.4$	ns
t_{RIP4}	Input Data Position 4 (T=11.76ns)	$4T/7-0.4$	$4T/7$	$4T/7+0.4$	ns
t_{RIP3}	Input Data Position 5 (T=11.76ns)	$5T/7-0.4$	$5T/7$	$5T/7+0.4$	ns
t_{RIP2}	Input Data Position 6 (T=11.76ns)	$6T/7-0.4$	$6T/7$	$6T/7+0.4$	ns
t_{RPLL}	Phase Lock Loop Set			10.0	ms

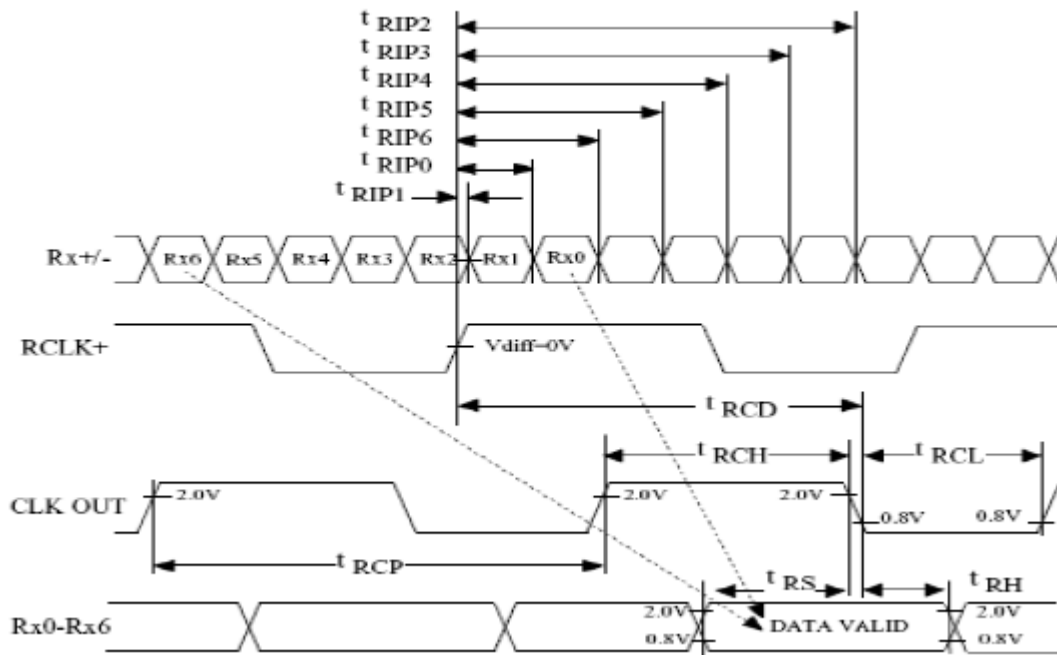

3.3.6 LVDS Data Mapping

	TA0	TA1	TA2	TA3	TA4	TA5	TA6	TB0	TB1	TB2	TB3	TB4	TB5	TB6	TC0	TC1	TC2	TC3	TC4	TC5	TC6
6BIT	R0	R1	R2	R3	R4	R5	G0	G1	G2	G3	G4	G5	B0	B1	B2	B3	B4	B5	HS	VS	DE

3.4 Back-Light Unit

The Back-light system is an edge-lighting type with 30 white LEDs(Light Emitting Diode).
The characteristics of 30 white LEDs are shown in the following tables.

(Ta= Room Temp)

Characteristics		Symbol	Min.	Typ.	Max.	Unit	Note
Current of Back-light Unit		I_B	-	200	TBD	mA	(1)
Voltage of Back-light Unit		V_B	-	(9.6)		V	
Power Consumption		P_{BL}	-	(1920)		mW	(2)
LED Life Time	25°C	-	(30000)			hr	(3)

Note (1) LEDs in 3 series x 10 parallel type.

(2) Where $I_B = 200\text{mA}$, $V_B = 9.6$, $P_{BL} = V_B \times I_B$

(3) The environmental conducted under ambient air flow ,at $T_a=25\pm 2^\circ\text{C}$, $60\%\text{RH}\pm 5\%$

4 Optical Characteristics

4.1 Optical characteristic of the LCD

The following items are measured under stable conditions. The optical characteristics should be measured in a dark room or equivalent state.

Measuring equipment: BM-5A ,BM-7

Item	Symbol	Condition	Min	Typ	Max	Unit	Note
Brightness			560	(700)	--	cd/m ²	
Response time	T_r	$\theta=0^\circ$	-	15	20	ms	.
	T_f		--	25	35	ms	
Contrast ratio	CR	At optimized viewing angle	400	(500)	--	--	
Color Gamut	NTSC %	--	--	50	--	%	
Color Chromaticity (CIE 1931)	Red	R_x	$\theta=0^\circ$ Normal Viewing Angle	0.565	0.615	0.665	--
		R_y		0.294	0.344	0.394	
	Green	G_x		0.257	0.307	0.357	--
		G_y		0.512	0.562	0.612	
	Blue	B_x		0.090	0.140	0.190	--
		B_y		0.080	0.130	0.180	
	White	W_x		0.259	0.309	0.359	--
		W_y		0.300	0.350	0.400	
Viewing Angle (6H)	Hor.	θ_R	$CR\geq 10$	55	65	--	Degree
		θ_L		55	65	--	
	Ver.	ϕ_H		40	50	--	
		ϕ_L		55	65	--	

a. Test equipment setup

After stabilizing and leaving the panel alone shall be warmed up for the stable operation of LCM, the measurement should be executed. Measurement should be executed in a stable, windless, and dark room. Optical specifications are measured by Topcon BM-7(fast) with a viewing angle of 2° at a distance of 50cm and normal direction.

b. Definition of response time: Tr and Tf

The response time is defined as the following figure and shall be measured by switching the input signal for "black" and "white".

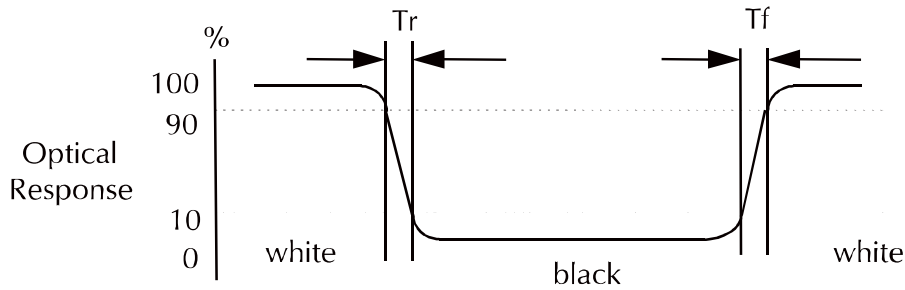

c. Definition of contrast ratio:

$$\text{Contrast Ratio (CR)} = \frac{\text{Brightness measured when LCD is at "white state"}}{\text{Brightness measured when LCD is at "black state"}}$$

d. Measured at the center area of the panel when all the input terminals of LCD panel are electrically opened.

e. View Angle

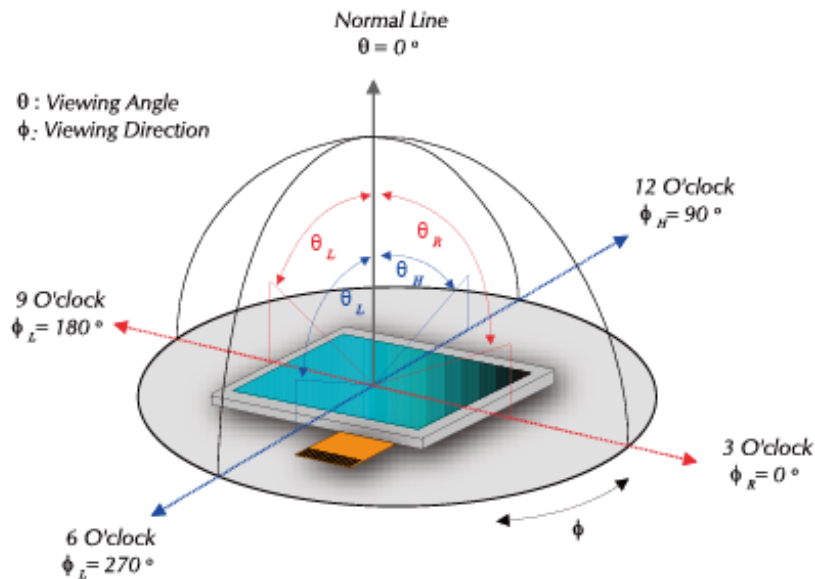

f. Definition of Luminance of White: Luminance of white at the center points

Light Source of Back-Light Unit	LED Type
---------------------------------	----------

g. Definition of White Uniformity

$$\text{White Uniformity} = \frac{\text{Min. luminance of white among 9-points}}{\text{Max. luminance of white among 9-points}}$$

h. The definition of Color Gamut -Color Chromaticity CIE 1931

Color coordinate of white & red, green, blue at center point.

$$\text{Color Gamut : NTSC(\%)} = (\text{RGB Triangle Area} / \text{NTSC Triangle Area}) \times 100$$

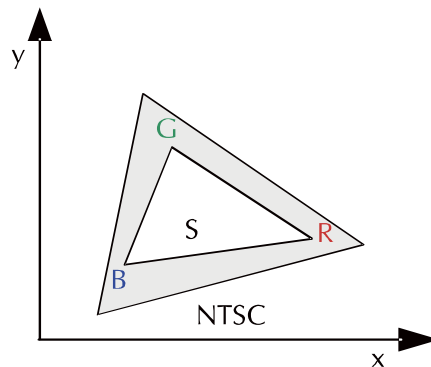

5 Input Terminal Pin Assignment

5.1 Pin Assignment

Pin No.	Symbol	I/O	Function	Remark
1	VCC	P	Power Supply 3.3V	
2	VCC	P	Power Supply 3.3V	
3	VSS	P	Ground	
4	VSS	P	Ground	
5	RXIN0-	I	LVDS Data Differential Pair 0 input	
6	RXIN0+	I	LVDS Data Differential Pair 0 input	
7	VSS	P	Ground	
8	RXIN1-	I	LVDS Data Differential Pair 1 input	
9	RXIN1+	I	LVDS Data Differential Pair 1 input	
10	VSS	P	Ground	
11	RXIN2-	I	LVDS Data Differential Pair 2 input	
12	RXIN2+	I	LVDS Data Differential Pair 2 input	
13	VSS	P	Ground	
14	RXCLK-	I	LVDS Clock Differential input	
15	RXCLK+	I	LVDS Clock Differential input	
16	VSS	P	Ground	
17	NC	-	NC	
18	NC	-	NC	
19	REV	I	Select horizontal and vertical scanning direction.	Note 1
20	VSS	P	Ground	

5.2 Back-light Unit (BLU)

Pin No.	Symbol	Function	Remark
1	LEDA	Power Supply for LED backlight	Red
2	LEDK	GND for LED backlight	Black

Connector: JST BHSR-02VS-1

5.3 Block Diagram

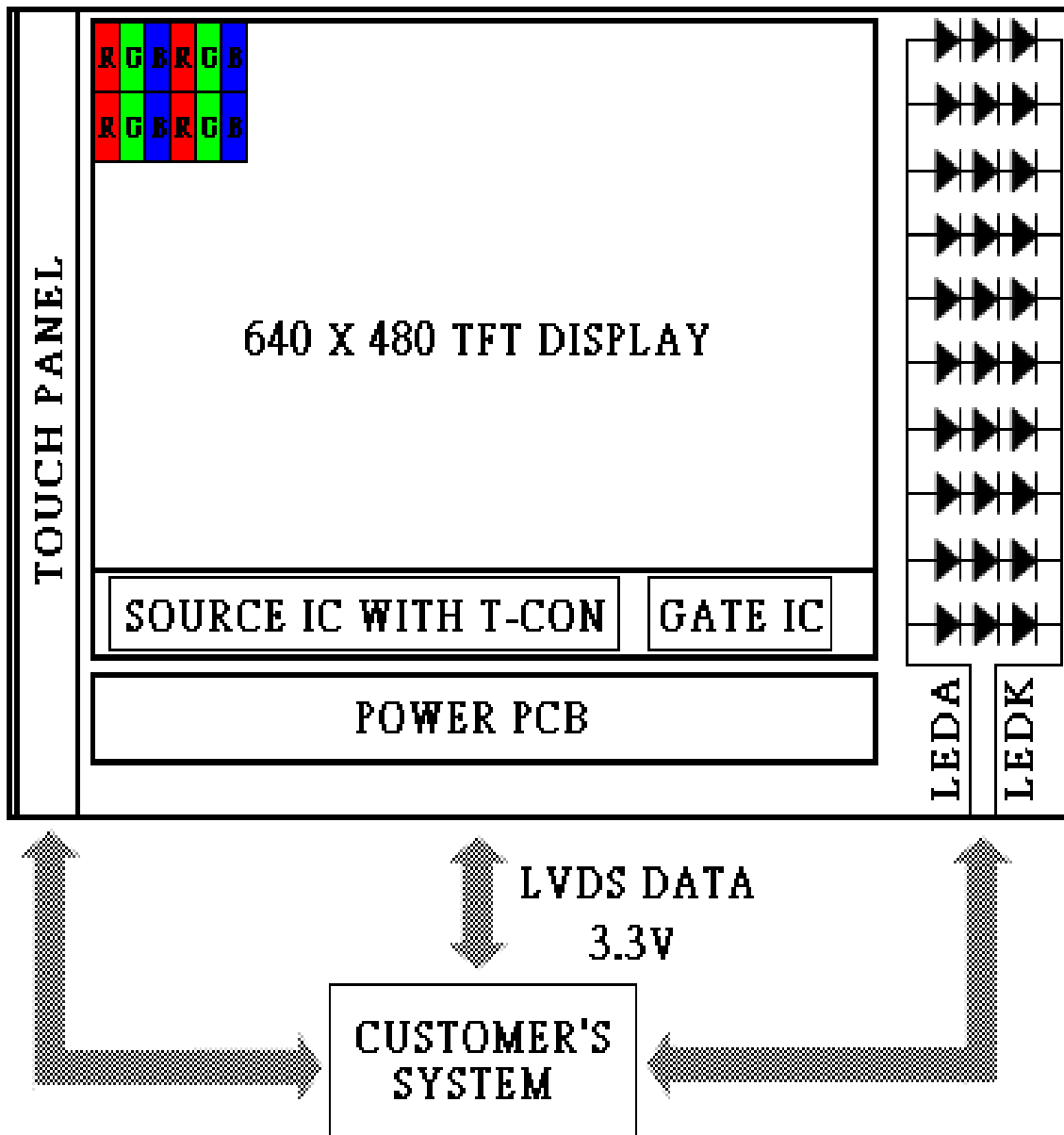

5.4 Basic Display Color and Gray Scale

	Color & Gray Scale	Data Signal																	
		R5	R4	R3	R2	R1	R0	G5	G4	G3	G2	G1	G0	B5	B4	B3	B2	B1	B0
Basic Color	Black	0	0	0	0	0	0	0	0	0	0	0	0	0	0	0	0	0	0
	Red(0)	1	1	1	1	1	1	0	0	0	0	0	0	0	0	0	0	0	0
	Green(0)	0	0	0	0	0	0	1	1	1	1	1	1	0	0	0	0	0	0
	Blue(0)	0	0	0	0	0	0	0	0	0	0	0	0	1	1	1	1	1	1
	Cyan	0	0	0	0	0	0	1	1	1	1	1	1	1	1	1	1	1	1
	Magenta	1	1	1	1	1	1	0	0	0	0	0	0	1	1	1	1	1	1
	Yellow	1	1	1	1	1	1	1	1	1	1	1	1	0	0	0	0	0	0
	White	1	1	1	1	1	1	1	1	1	1	1	1	1	1	1	1	1	1
Red	Black	0	0	0	0	0	0	0	0	0	0	0	0	0	0	0	0	0	0
	Red(62)	0	0	0	0	0	1	0	0	0	0	0	0	0	0	0	0	0	0
	Red(61)	0	0	0	0	1	0	0	0	0	0	0	0	0	0	0	0	0	0
	:	:	:	:	:	:	:	:	:	:	:	:	:	:	:	:	:	:	:
	Red(31)	0	1	1	1	1	1	0	0	0	0	0	0	0	0	0	0	0	0
	:	:	:	:	:	:	:	:	:	:	:	:	:	:	:	:	:	:	:
	Red(1)	1	1	1	1	1	0	0	0	0	0	0	0	0	0	0	0	0	0
	Red(0)	1	1	1	1	1	1	0	0	0	0	0	0	0	0	0	0	0	0
Green	Black	0	0	0	0	0	0	0	0	0	0	0	0	0	0	0	0	0	0
	Green(62)	0	0	0	0	0	0	0	0	0	0	0	1	0	0	0	0	0	0
	Green(61)	0	0	0	0	0	0	0	0	0	0	1	0	0	0	0	0	0	0
	:	:	:	:	:	:	:	:	:	:	:	:	:	:	:	:	:	:	:
	Green(31)	0	0	0	0	0	0	0	1	1	1	1	1	0	0	0	0	0	0
	:	:	:	:	:	:	:	:	:	:	:	:	:	:	:	:	:	:	:
	Green(1)	0	0	0	0	0	0	1	1	1	1	1	0	0	0	0	0	0	0
	Green(0)	0	0	0	0	0	0	1	1	1	1	1	1	0	0	0	0	0	0
Blue	Black	0	0	0	0	0	0	0	0	0	0	0	0	0	0	0	0	0	0
	Blue(62)	0	0	0	0	0	0	0	0	0	0	0	0	0	0	0	0	0	1
	Blue(61)	0	0	0	0	0	0	0	0	0	0	0	0	0	0	0	0	0	1
	:	:	:	:	:	:	:	:	:	:	:	:	:	:	:	:	:	:	:
	Blue(31)	0	0	0	0	0	0	0	0	0	0	0	0	0	1	1	1	1	1
	:	:	:	:	:	:	:	:	:	:	:	:	:	:	:	:	:	:	:
	Blue(1)	0	0	0	0	0	0	0	0	0	0	0	0	1	1	1	1	1	0
	Blue(0)	0	0	0	0	0	0	0	0	0	0	0	0	1	1	1	1	1	1

0 : Low level voltage, 1 :High level voltage

Each basic color can be displayed in 64 gray scales from 6 bit data signals. With the combination of total 18 bit data signals, the 262,144-color display can be achieved on the screen.

6 Touch Screen Panel

6.1 Electrical Characteristics

Item	Min.	Typ.	Max.	Unit	Note
Linearity	-	-	1.5	%	Analog X and Y directions
Terminal resistance	200	-	900	Ω	X (Glass side)
	200	-	900	Ω	Y (Film side)
Insulation resistance	20	-	-	M Ω	DC 25V
Voltage	-	5.0	15	V	DC
Chattering	-	-	15	ms	100k Ω pull-up
Transparency	-	80	-	%	Anti-glare

6.2 Mechanical & Reliability Characteristics

Item	Min.	Typ.	Max.	Unit	Note
Operation force	-	60	100	g	
Hitting Test	1,000,000	-	-	times	
Surface hardness	3	-	-	H	According to (JIS-K5400)

7 Reliability Condition

No change on display and in operation under the following test condition.

Condition: Unless otherwise specified, tests will be conducted under the following condition.

Temperature: 20±5°C Humidity: 65±5%RH

Tests will be not conducted under functioning state.

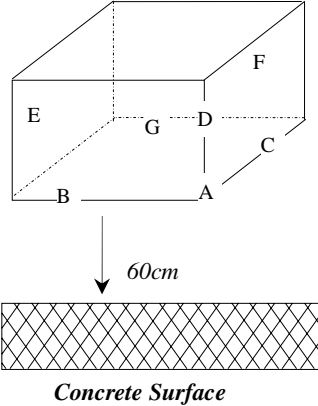
No.	Parameter	Condition	Notes
1	High Temperature Operating	70°C±2°C, 240hrs (Operation state)	-
2	Low Temperature Operating	-20°C±2°C, 240hrs (Operation state)	-
3	High Temperature Storage	80°C±2°C, 240hrs	-
4	Low Temperature Storage	-30°C±2°C, 240hrs	-
5	High Temperature and High Humidity Operation Test	60°C±2°C, 90%, 240hrs.	-
6	Vibration Test	Total fixed amplitude: 1.5mm Vibration Frequency: 10~55Hz One cycle 60 seconds to 3 direction of X, Y, Z each 15 minutes.	-
7.	Drop Test	To be measured after dropping from 60cm high on the concrete surface in packing state.  <i>Dropping method corner dropping</i> <i>A corner: once</i> <i>Edge dropping</i> <i>B, C, D edge: once</i> <i>Face dropping</i> <i>E, F, G face: once</i>	-

8 Dimensional Outlines

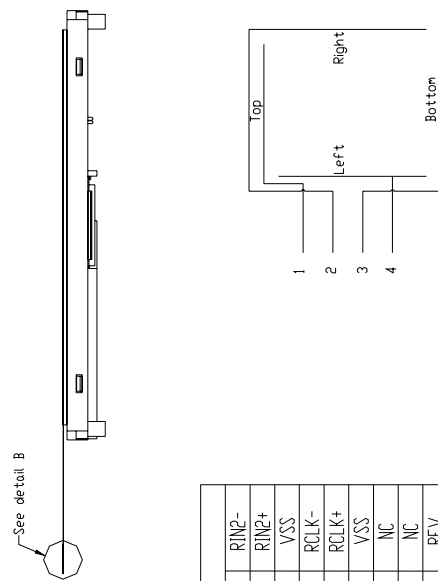
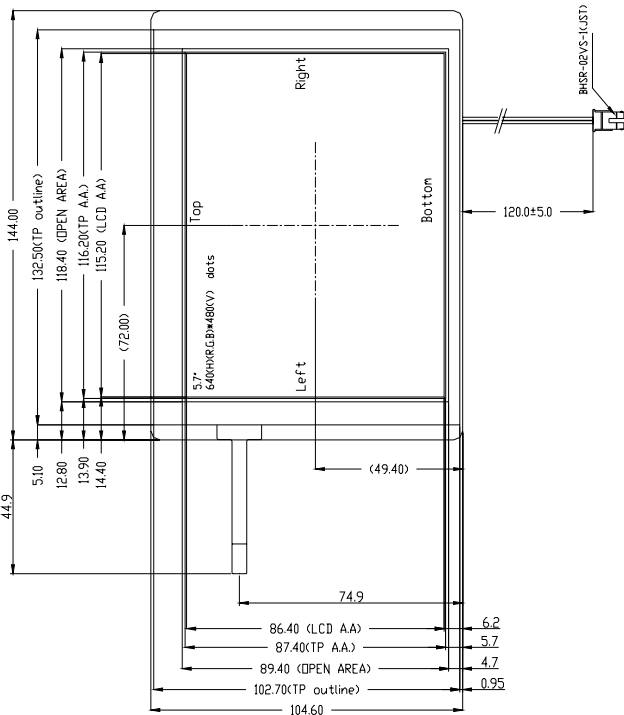
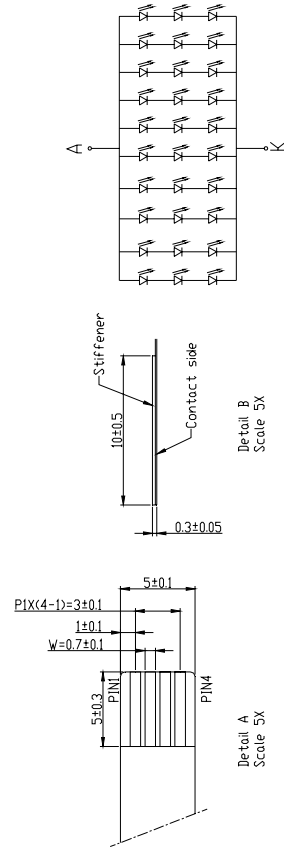
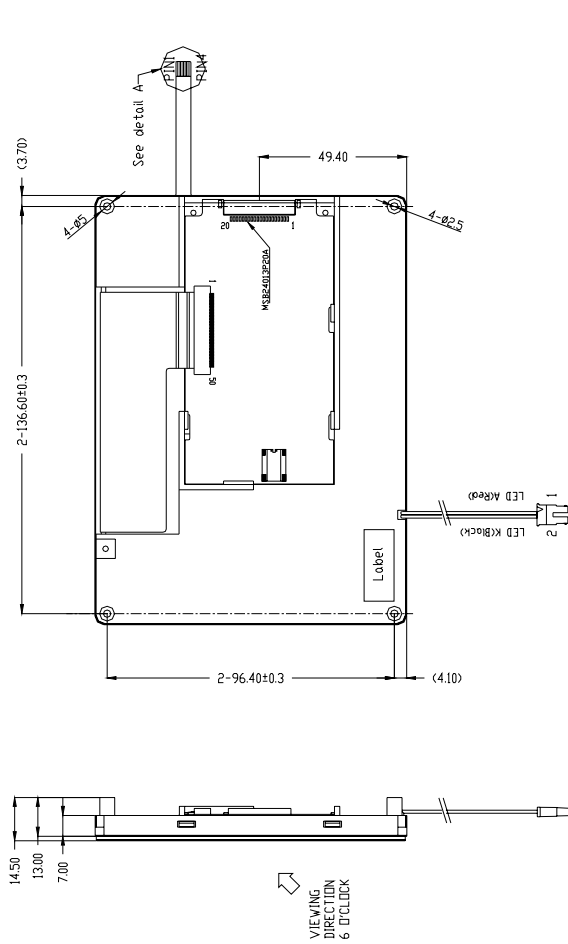

No:	PIN NAME	11	RIN2-	12	RIN2+	13	VSS	14	RCLK-	15	RCLK+	16	VSS	17	NC	18	NC	19	REV	20	VSS
1	VCC																				
2	VCC																				
3	VSS																				
4	VSS																				
5	RIN0-																				
6	RIN0+																				
7	VSS																				
8	RIN1-																				
9	RIN1+																				
10	VSS																				