

Display Elektronik GmbH

DATA SHEET

TFT MODULE

DEM 480272N TMH-PW-N

4,3“ TFT

Product Specification

Ver.: 1

29.08.2014

Contents

	Page
1. Revision History	3
2. General Specification	4
3. Interface Pin Function	6
4. Contour Drawing	7
5. Block Diagram	8
6. Absolute Maximum Ratings	9
7. Electrical Characteristics	10
8. DC Characteristics	10
9. AC Characteristics	11
10. Optical Characteristics	13
11. Reliability	15

1. Revision History

DATE	VERSION	REVISED PAGE NO.	Note
29.08.2014	0		Preliminary
29.08.2014	1		First Issue

2. General Specification

This technical specification applies to 4.3' color TFT-LCD panel. The 4.3' color TFT-LCD panel is designed for camcorder, digital camera application and other electronic products which require high quality flat panel displays. This module follows RoHS.

- Dot Matrix: 480 x RGB x 272
- Module Dimension: 105.50 x 67.20 x 2.90 mm
- Active Area: 95.04 x 53.86 mm
- Dot Pitch: 0.066 x 0.198 mm
- LCD Type: TFT, Normally White, Transmissive
- View Direction: 12 o'clock
- Gray Scale Inversion Direction: 6 o'clock
- Backlight Type: LED, Normally White

*Color tone slight changed by temperature and driving voltage.

3. Interface Pin Function

3.1 LCM PIN Definition

Pin	Symbol	Function	Remark
1	VBL-	Power for LED backlight cathode	
2	VBL+	Power for LED backlight anode	
3	GND	Power ground	
4	VCC	Power voltage	
5	R0	Red data (LSB)	
6	R1	Red data	
7	R2	Red data	
8	R3	Red data	
9	R4	Red data	
10	R5	Red data	
11	R6	Red data	
12	R7	Red data (MSB)	
13	G0	Green data (LSB)	
14	G1	Green data	
15	G2	Green data	
16	G3	Green data	
17	G4	Green data	
18	G5	Green data	
19	G6	Green data	
20	G7	Green data (MSB)	
21	B0	Blue data (LSB)	
22	B1	Blue data	
23	B2	Blue data	
24	B3	Blue data	
25	B4	Blue data	
26	B5	Blue data	
27	B6	Blue data	
28	B7	Blue data (MSB)	
29	GND	Power ground	
30	DCLK	Pixel clock	
31	DISP	Display on/off	
32	NC	No connection	
33	NC	No connection	
34	DE	Data Enable	
35	NC	No connection	
36	GND	Power ground	
37	NC	No connection	
38	NC	No connection	
39	NC	No connection	
40	NC	No connection	

4. Drawing

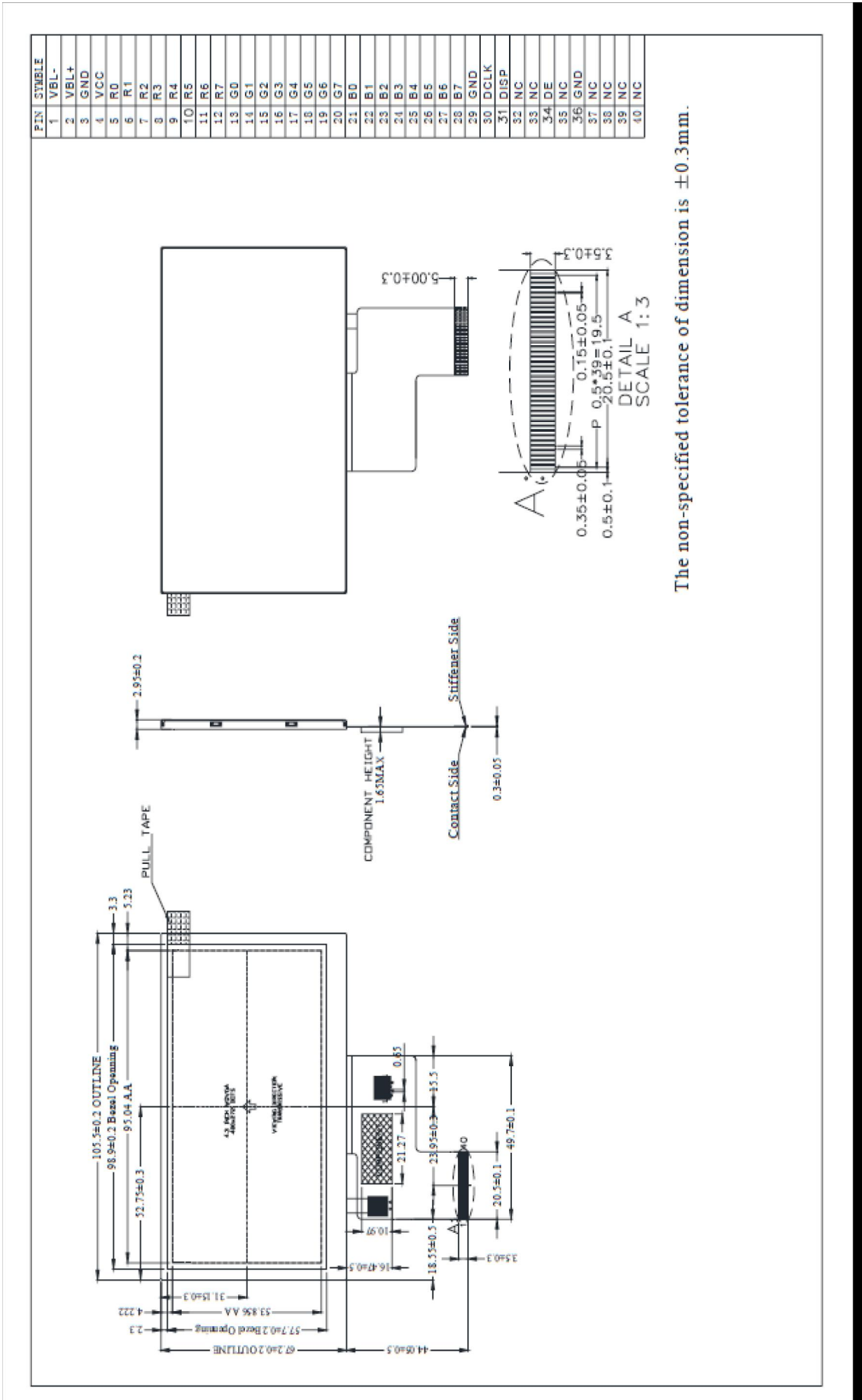

The non-specified tolerance of dimension is ±0.3mm.

5. Block Diagram

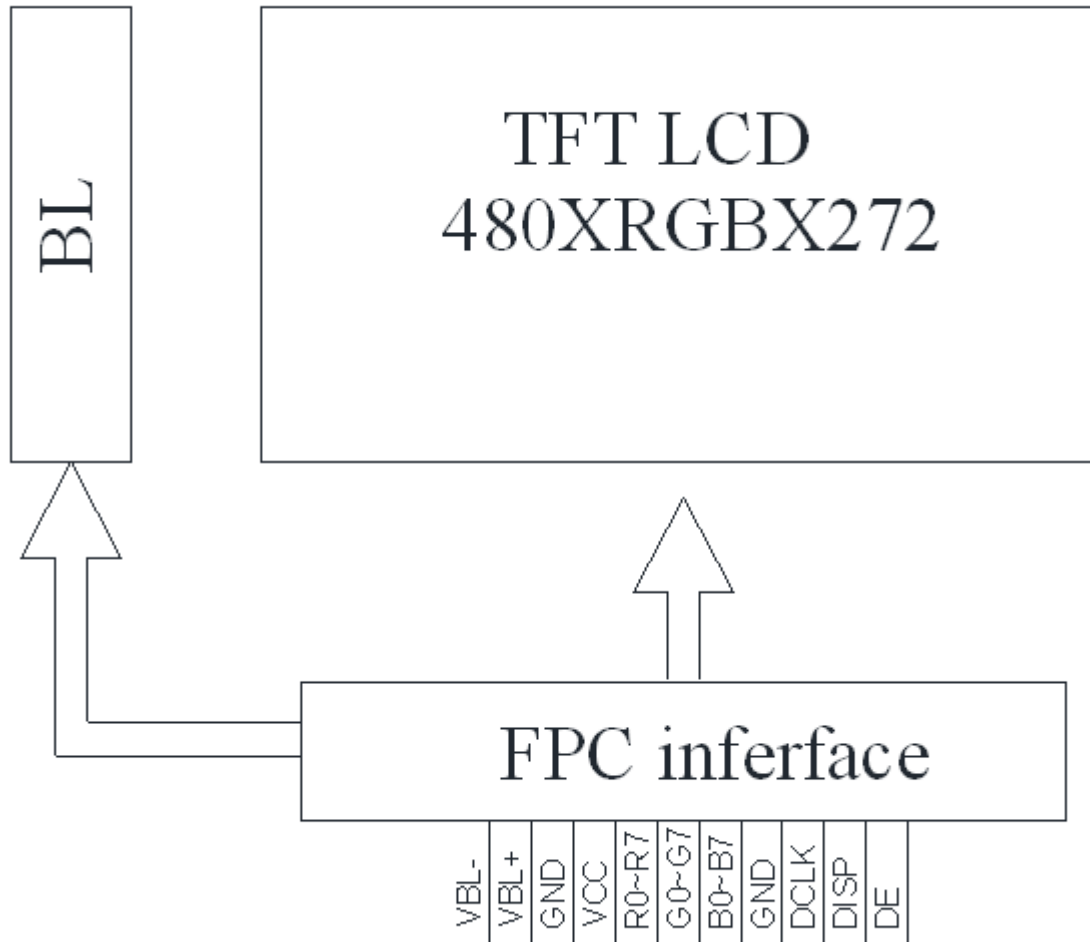

6. Absolute Maximum Ratings

Item	Symbol	Min	Typ	Max	Unit
Operating Temperature	TOP	-20	—	+70	° C
Storage Temperature	TST	-30	—	+80	° C

Note: Device is subject to be damaged permanently if stresses beyond those absolute maximum ratings listed above

1. Temp. $\leq 60^{\circ}\text{C}$, 90% RH MAX. Temp. $> 60^{\circ}\text{C}$, Absolute humidity shall be less than 90% RH at 60°C

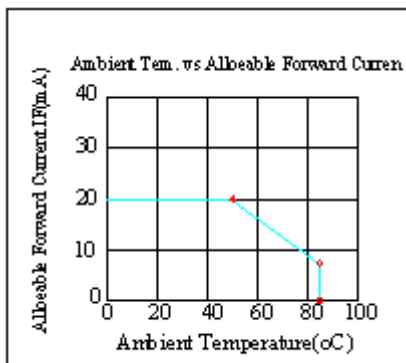

7. Electrical Characteristics

7.1 Operating conditions:

Item	Symbol	Condition	Min	Typ	Max	Unit
Supply Voltage For Logic	VCC	—	3	3.3	3.6	V
Digital operation current	Icc	—	—	17	25	mA

7.2 LED driving conditions

Parameter	Symbol	Min.	Typ.	Max.	Unit	Remark
LED current	—	18	20	30	mA	
Power Consumption	—	—	640	990	mW	
LED voltage	VBL+	30	32	33	V	Note 1
LED Life Time		20,000	—	—	Hr	Note 2,3,4

Note 1 : There are 1 Groups LED

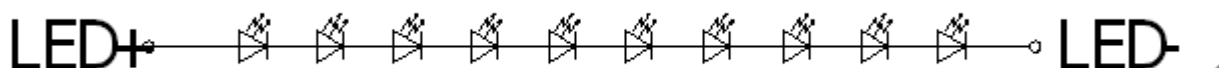

Note 2 : Ta = 25°C

Note 3 : Brightness to be decreased to 50% of the initial value

Note 4 : The single LED lamp case

8. DC Characteristics

Parameter	Symbol	Rating			Unit	Condition
		Min	Typ	Max		
Low level input voltage	V _{IL}	0	-	0.2VCC	V	
High level input voltage	V _{IH}	0.8VCC	-	VCC	V	

9. AC Characteristics

Parallel RGB Interface

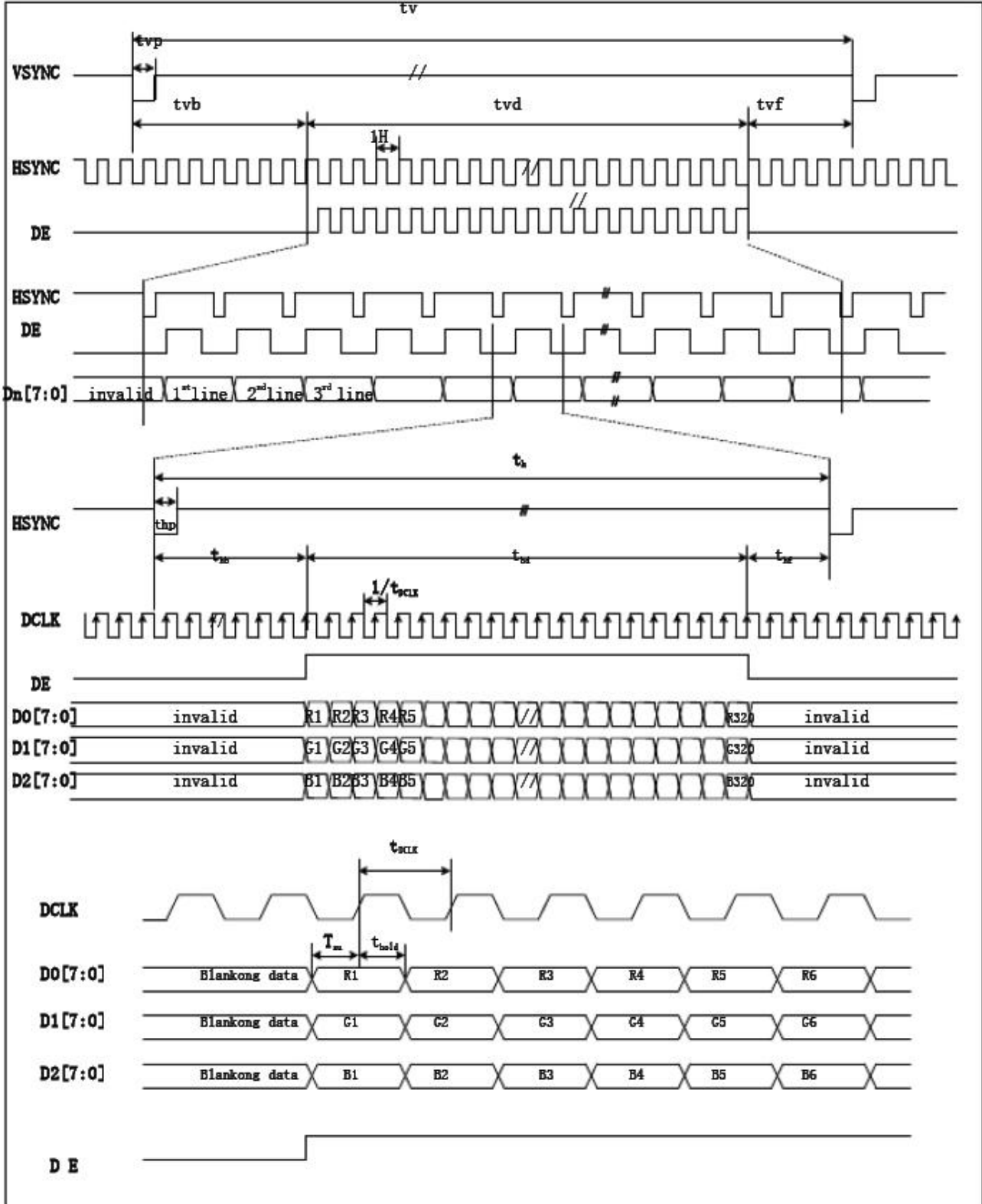

Parameter	Symbol	Min.	Typ.	Max.	Unit.	Note
DCLK Frequency	1/tDCLK	5	9	12	MHz	
Horizontal Period	th	520	525	800	tDCLK	
Horizontal Display	thd	-	480	-	tDCLK	
Horizontal Back Porch	thb	36	40	255	tDCLK	
Horizontal Front Porch	thf	4	5	65	tDCLK	
Horizontal Pulse Width	thp	1	-	-	tDCLK	
Vertical Period	tv	277	288	400	th	
Vertical Display Period	tvd	-	272	-	th	
Vertical Back Porch	tvb	3	8	31	th	
Vertical Front Porch	tvf	2	8	97	th	
Vertical Pulse Width	tvp	1	-	-	th	
Data setup time	tsu	12	-	-	ns	
Data hold time	thold	12	-	-	ns	

10. Optical Characteristics

Item	Symbol	Condition.	Min	Typ.	Max.	Unit	Remark	
Response Time	Tr	$\theta=0^\circ, \phi=0^\circ$	-	10	20	ms	Note 3	
	Tf		-	15	30	ms		
Contrast Ratio	CR	At optimized viewing angle	400	500	-	-	Note 4	
Color Chromaticity	White	Wx	$\theta=0^\circ, \phi=0^\circ$	0.26	0.31	0.36	-	Note 2,5
		Wy		0.28	0.33	0.38	-	
Viewing angle	Hor.	ΘR	$CR \geq 10$	60	70	-	Deg.	Note 1
		ΘL		60	70	-		
	Ver.	ΦT		40	50	-		
		ΦB		60	70	-		
Brightness	-	-	400	500	-	cd/m ²	Center of display	

Ta=25±2°C

Note 1: Definition of viewing angle range

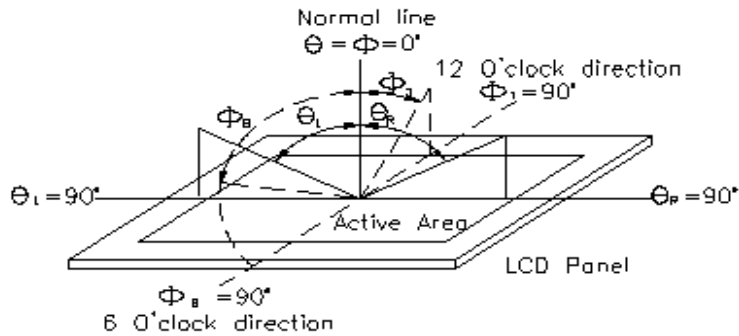

Fig. 11.1. Definition of viewing angle

Note 2: Test equipment setup:

After stabilizing and leaving the panel alone at a driven temperature for 10 minutes, the measurement should be executed. Measurement should be executed in a stable, windless, and dark room. Optical specifications are measured by Topcon BM-7orBM-5 luminance meter 1.0° field of view at a distance of 50cm and normal direction.

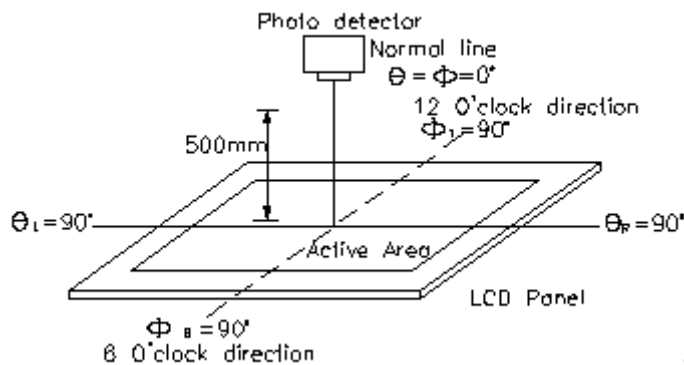
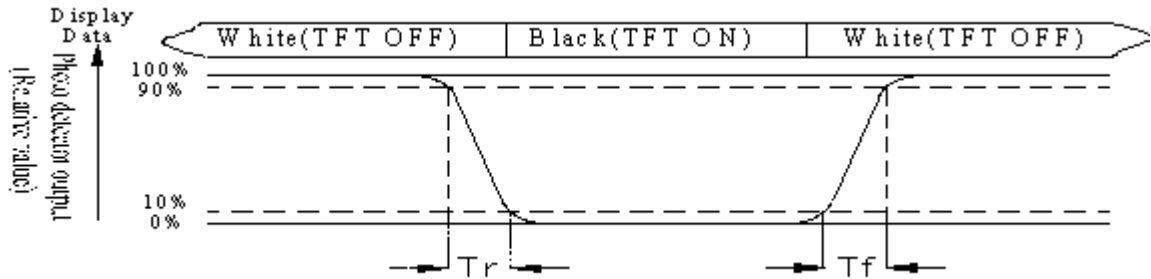

Fig. 11.2. Optical measurement system setup

Note 3: Definition of Response time:

The response time is defined as the LCD optical switching time interval between “White” state and “Black” state. Rise time, Tr, is the time between photo detector output intensity changed from 90%to 10%. And fall time, Tf, is the time between photo detector output intensity changed from 10%to 90%



Note 4: Definition of contrast ratio:

The contrast ratio is defined as the following expression.

$$\text{Contrast ratio (CR)} = \frac{\text{Luminance measured when LCD on the "White" state}}{\text{Luminance measured when LCD on the "Black" state}}$$

Note 5: White Vi = Vi50 ± 1.5V

Black Vi = Vi50 ± 2.0V

“±” means that the analog input signal swings in phase with VCOM signal.

“±” means that the analog input signal swings out of phase with VCOM signal.

The 100% transmission is defined as the transmission of LCD panel when all the input terminals of module are electrically opened.

Note 6: Definition of color chromaticity (CIE 1931)

Color coordinates measured at the center point of LCD

Note 7: Measured at the center area of the panel when all the input terminals of LCD panel are electrically opened.

$$\text{Note 8: Uniformity (U)} = \frac{\text{Brightness(min)}}{\text{Brightness(max)}} \times 100\%$$

11. Reliability

Content of Reliability Test (Wide temperature, -20°C~70°C)

Environmental Test			
Test Item	Content of Test	Test Condition	Note
High Temperature storage	Endurance test applying the high storage temperature for a long time.	80° C 200hrs	2
Low Temperature storage	Endurance test applying the low storage temperature for a long time.	-30° C 200hrs	1,2
High Temperature Operation	Endurance test applying the electric stress (Voltage & Current) and the thermal stress to the element for a long time.	70° C 200hrs	—
Low Temperature Operation	Endurance test applying the electric stress under low temperature for a long time.	-20° C 200hrs	1
High Temperature/ Humidity Operation	The module should be allowed to stand at 60° C,90%RH max For 96hrs under no-load condition excluding the polarizer, Then taking it out and drying it at normal temperature.	60° C,90%RH 96hrs	1,2
Thermal shock resistance	The sample should be allowed stand the following 10 cycles of operation <div style="text-align: center;"> <p style="text-align: center;">-20°C 25°C 70°C 30min 5min 30min 1 cycle</p> </div>	-20° C/70° C 10 cycles	—
Vibration test	Endurance test applying the vibration during transportation and using.	Total fixed amplitude : 15mm Vibration Frequency : 10~55Hz One cycle 60 seconds to 3 directions of X,Y,Z for Each 15 minutes	3
Static electricity test	Endurance test applying the electric stress to the terminal.	C=150pF,R=330Ω,5point/panel Air:±8Kv,5times; Contact:±4Kv, 5times (Environment:15° C~35° C, 30%~60%.86Kpa~106Kpa)	—

Note1: No dew condensation to be observed.

Note2: The function test shall be conducted after 4 hours storage at the normal Temperature and humidity after remove from the test chamber.

Note3: The packing have to including into the vibration testing.