

DISPLAY Elektronik GmbH

DATA SHEET

LCD MODULE

DEM 128064C ADX-PW-N

Product Specification

Version: 2

17.09.2017

CONTENTS

1. FUNCTIONS & FEATURES2

2. MECHANICAL SPECIFICATIONS.....2

3. EXTERNAL DIMENSIONS.....3

4. BLOCK DIAGRAM.....4

5. PIN DESCRIPTION.....5

6. BACKLIGHT ELECTRICAL/OPTICAL SPECIFICATIONS6

7. ABSOLUTE MAXIMUM RATINGS7

8. ELECTRICAL CHARACTERISTICS7

9. COMMAND TABLE10

10. MODULE ACCEPT QUALITY LEVEL (AQL).....11

11. RELIABILITY TEST11

12. QUALITY DESCRIPTION12

13. LCD MODULES HANDLING PRECAUTIONS.....13

14. OTHERS.....13

1. FUNCTIONS & FEATURES

MODULE NAME	LCD TYPE	Remark
DEM 128064C ADX-PW-N	ASTN Transmissive Negative Mode	

- Viewing Direction : 6 O'clock
- Driving Scheme : 1/64 Duty Cycle, 1/9 Bias
- Power Supply Voltage : 3.3 Volt (typ.)
- LCD Operation Voltage (V0-Vss) : 11.0 Volt (typ.)
- Display Format : 128 x 64 Dots
- Driver IC : ST7565P (Sitronix)
- Interface : 6800 Series or 8080 Series
- RoHS Compliant

2. MECHANICAL SPECIFICATIONS

- Module Size : 38.00 x 26.40 x 9.00 mm (without FPC)
- Viewing Area : 29.58 x 17.98 mm
- Active Area : 25.58 x 15.98 mm
- Dot Size : 0.18 x 0.23 mm
- Dot Pitch : 0.20 x 0.25 mm
- Dot Gap : 0.02 mm

3. EXTERNAL DIMENSIONS

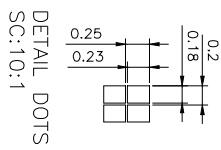
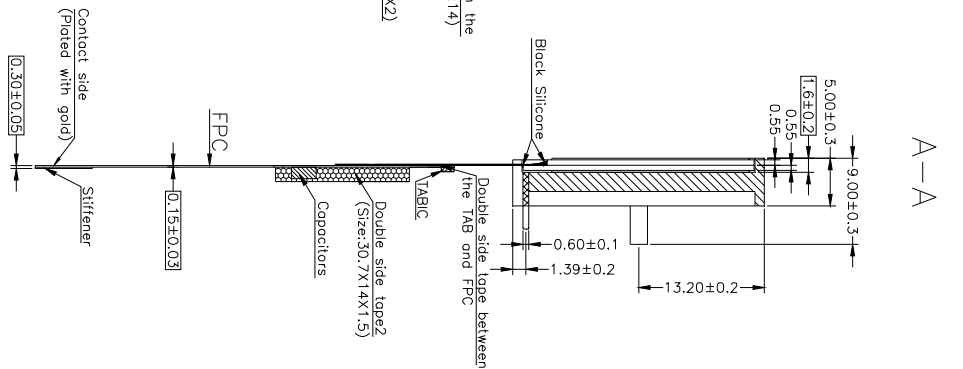
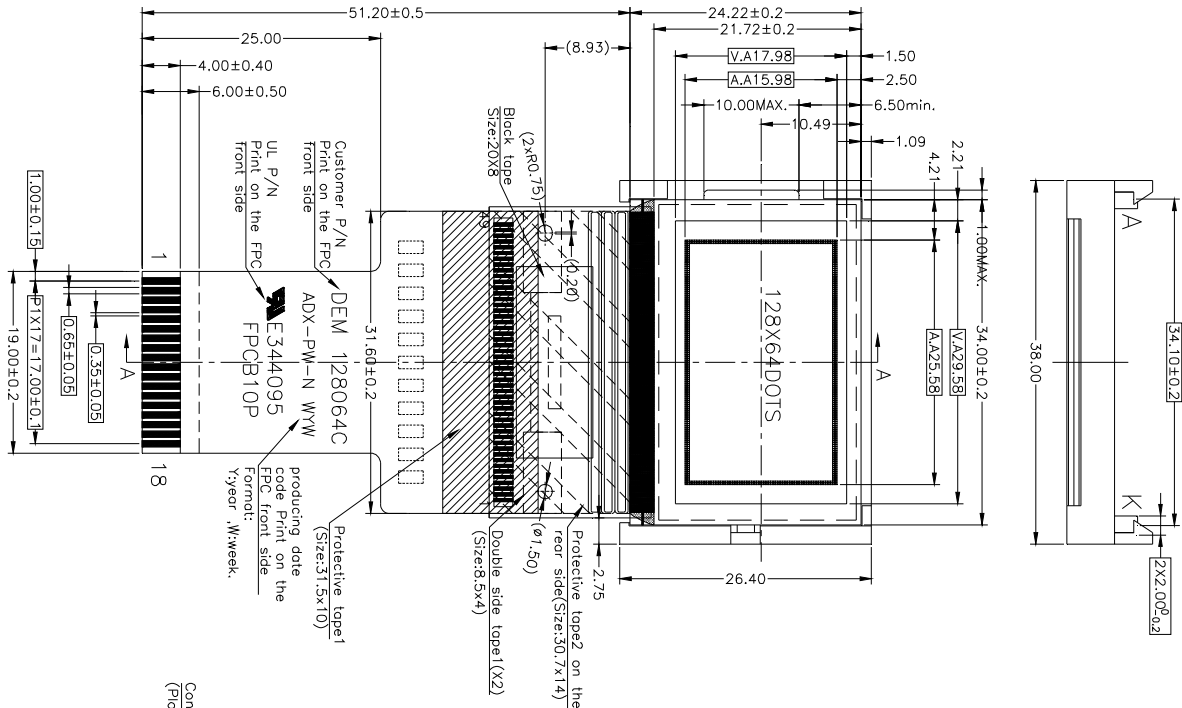

Remarks:
 1. Unmarked tolerance is ± 0.3 ,
 2. The material comply with RoHS and UL.
 3. ...:critical dimension.

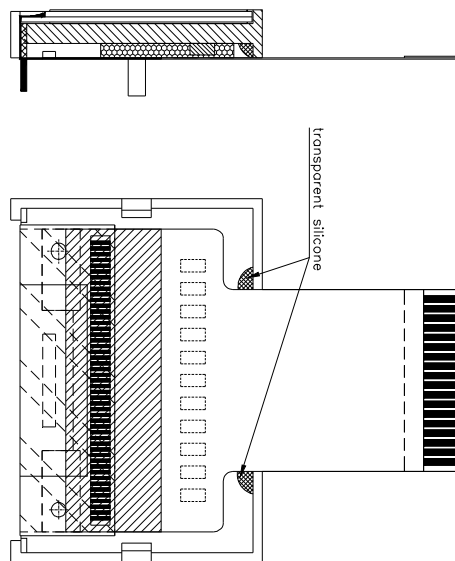

4. BLOCK DIAGRAM

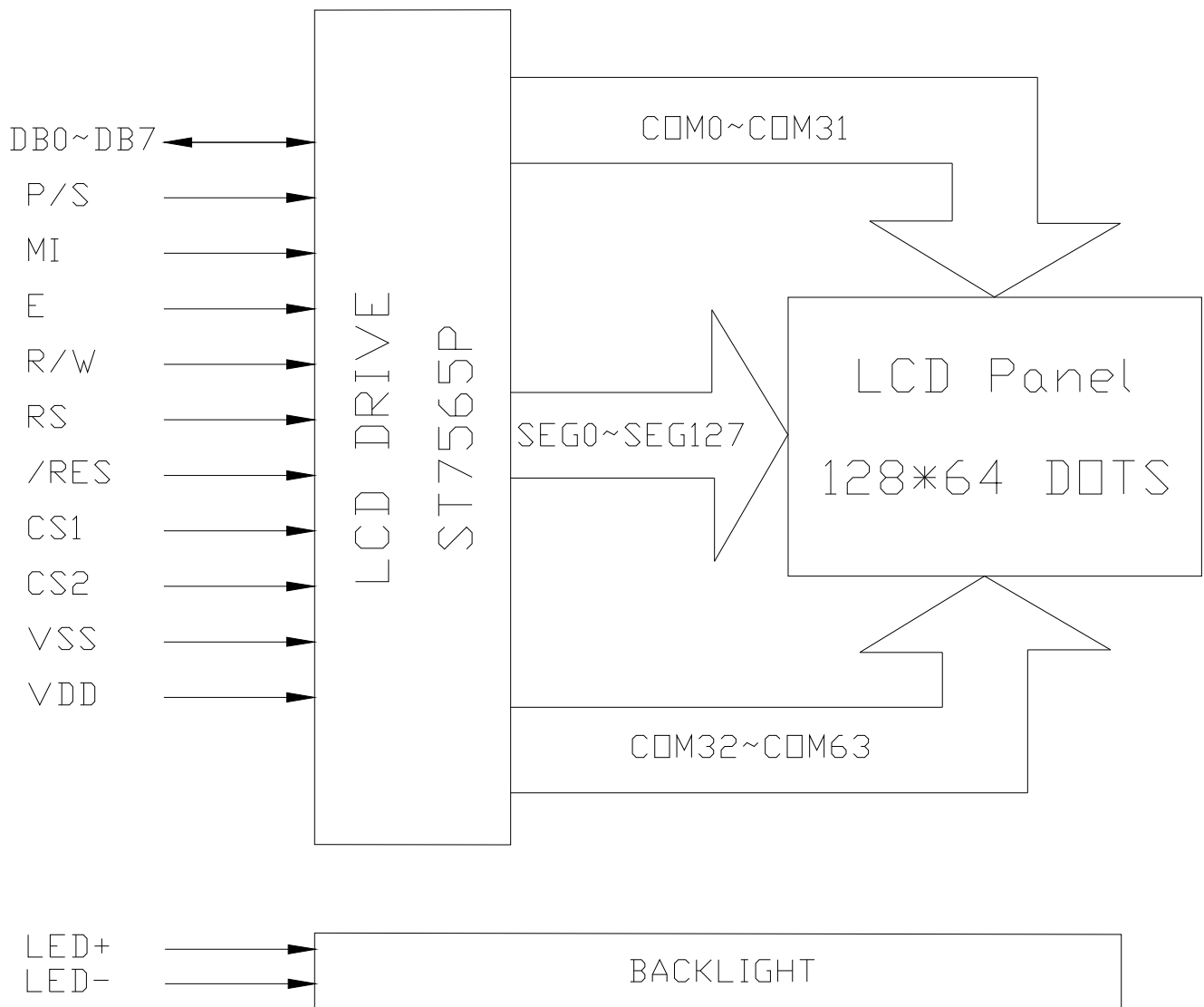

5. PIN DESCRIPTION

Pin No.	Name	Description															
1	VDD	Power supply(+3.3V)															
2	VSS	Ground															
3	CS1	This is the chip select signal. When /CS1="L" and CS2="H", then the chip select becomes active, and data/command I/O is enabled.															
4	CS2																
5	/RES	When/ RES is set to "L", the register settings are initialized (cleared). The reset operation is performed by the /RES signal level.															
6	RS	This is connecting to the least significant bit of the normal MPU address bus, and it determines whether the data bits are data or command. RS="H": Indicates that DB0 to DB7 are display data. RS="L": Indicates that DB0 to DB7 are control data.															
7	R/W	When connected to 8080 series MPU, this pin is treated as the "/WR"signal of the 8080 MPU and is LOW-active. The signal on the data bus are latched at the rising edge of the /WR signal. When connected to 6800 series MPU, this pin is treated as the "R/W"signal of the 6800 MPU and decides the access type: When R/W ="H": Read. When R/W ="l": write.															
8	E	When connected to 8080 series MPU, this pin is treated as the "/RD"signal of the 8080 MPU and is LOW-active. The data bus is in an output status when this signal is "L". When connected to 6800 series MPU, this pin is treated as the "E"signal of the 6800 MPU and is HIGH-active. This is the enable clock input terminal of the 6800 series MPU.															
9~16	DB0~DB7	This is an 8-bit bi-directional data bus that connects to an 8-bit or 16-bit standard MPU data bus. When the serial interface (SPI-4) is selected (P/S="L") DB7: serial data input (SI); DB6: the serial clock input (SCL). DB0 to DB7 should be connected to VDD or floating. When the chip select is not active, DB0 to DB7 are set to high impedance.															
17	MI	This is the MPU interface selection pin. MI="H":6800 series MPU interface. MI="L":8080 series MPU interface.															
18	P/S	This pin configures the interface to be parallel mode or serial mode. P/S="H": Parallel data input/output. P/S="L": Serial data input. The following applies depending on the P/S status: <table border="1" style="width: 100%; border-collapse: collapse;"> <thead> <tr> <th>P/S</th> <th>Data/Command</th> <th>Data</th> <th>Read/Write</th> <th>Serial Clock</th> </tr> </thead> <tbody> <tr> <td>"H"</td> <td>A0</td> <td>DB0 to DB7</td> <td>/RD,/WR</td> <td>×</td> </tr> <tr> <td>"L"</td> <td>A0</td> <td>SI (DB7)</td> <td>Write only</td> <td>SCL (DB6)</td> </tr> </tbody> </table> When P/S="L",DB0 to DB5 must be fixed to"H" E and R/W are fixed to either "H" to "L". The serial access mode does NOT support read operation.	P/S	Data/Command	Data	Read/Write	Serial Clock	"H"	A0	DB0 to DB7	/RD,/WR	×	"L"	A0	SI (DB7)	Write only	SCL (DB6)
P/S	Data/Command	Data	Read/Write	Serial Clock													
"H"	A0	DB0 to DB7	/RD,/WR	×													
"L"	A0	SI (DB7)	Write only	SCL (DB6)													

6. BACKLIGHT ELECTRICAL/OPTICAL SPECIFICATIONS

ELECTRICAL / OPTICAL SPECIFICATIONS

PARAMETER	STMBOL	Min.	Typ.	Max	Unit	Test condition
AVERAGE LUMINOUS INTENSITY	I_v	170	300		cd/m ²	Ta=25°C Vf= 3.0V
LUMINOUS TOLERANCE / PCS		70			%	
FORWARD CURRENT	I_f		40	50	mA	
PEAK EMISSION WAVELENGTH	λ_P				nm	
CHROMATICITY COORDINATES	X Y	0.22 0.24	0.24 0.30	0.30 0.32		
ITEM	STMBOL	ABS. MAXIMUM RATING			TEST CONDITION	
FORWARD CURRENT	I_f	40mA			Ta=25°C	
REVERSE VOLTAGE	V_r	5 V				
POWER DISSIPATION	P_d	132mW				
OPERATING TEMPERATURE	T_{opr}	-30 ~ +80 °C				
STORAGE TEMPERATURE	T_{stg}	-40 ~ +90 °C				

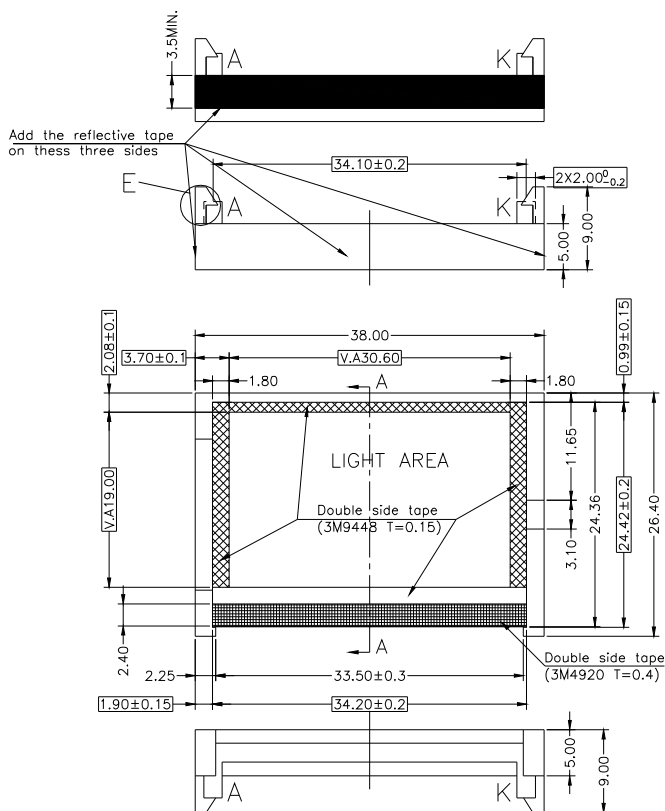

Circuit Diagram

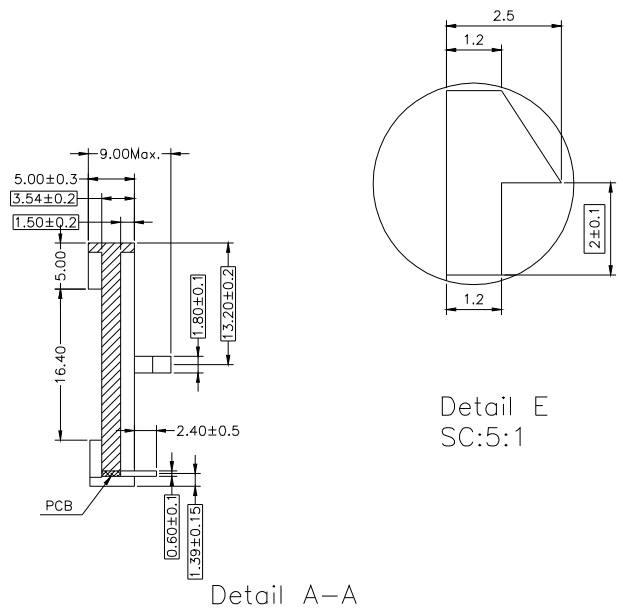
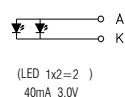

- Remarks:
- 1.Unmarked tolerance is ±0.2,
 - 2.The material comply with RoHS and UL,
 - 3.Color:White,
 - 4.Life Time:>=50000Hours.

7. ABSOLUTE MAXIMUM RATINGS

Parameter	Symbol	Conditions	Unit
Power Supply Voltage(1)	V _{DD}	+2.4 ~ +3.6	V
Power supply voltage (2)	V _{LCD}	+4.0 ~ +15.0	V
Input voltage	V _{IN}	-0.3 to V _{DD} + 0.3 V	V
Output voltage	V _O	-0.3 to V _{DD} + 0.3	V
Operating temperature	T _{OPR}	-30 ~ +80	°C
Storage temperature	T _{STR}	-40~ +90	°C

8. ELECTRICAL CHARACTERISTICS

8.1 DC CHARACTERISTICS

(V_{SS}=0V, T_a= 25°C)

PARAMETER	SYMBOL	STANDARD VALUE			TEST CONDITION	UNIT
		MIN	TYP	MAX	Condition	
Operation Voltage	V _{DD}	3.0	3.3	3.6	--	V
LCD Operation Voltage	V _{LCD}	10.7	11.0	11.3	--	V
Current Consumption	I _{DD}	--	272	408	Display pattern: snow	uA
		--	160	240	All ON/All OFF/Display Character	

8.2 AC ELECTRICAL CHARACTERISTICS.

(VSS=0V, Ta=25°C)

System Bus Read/Write Characteristics 1 (For the 8080 Series MPU)

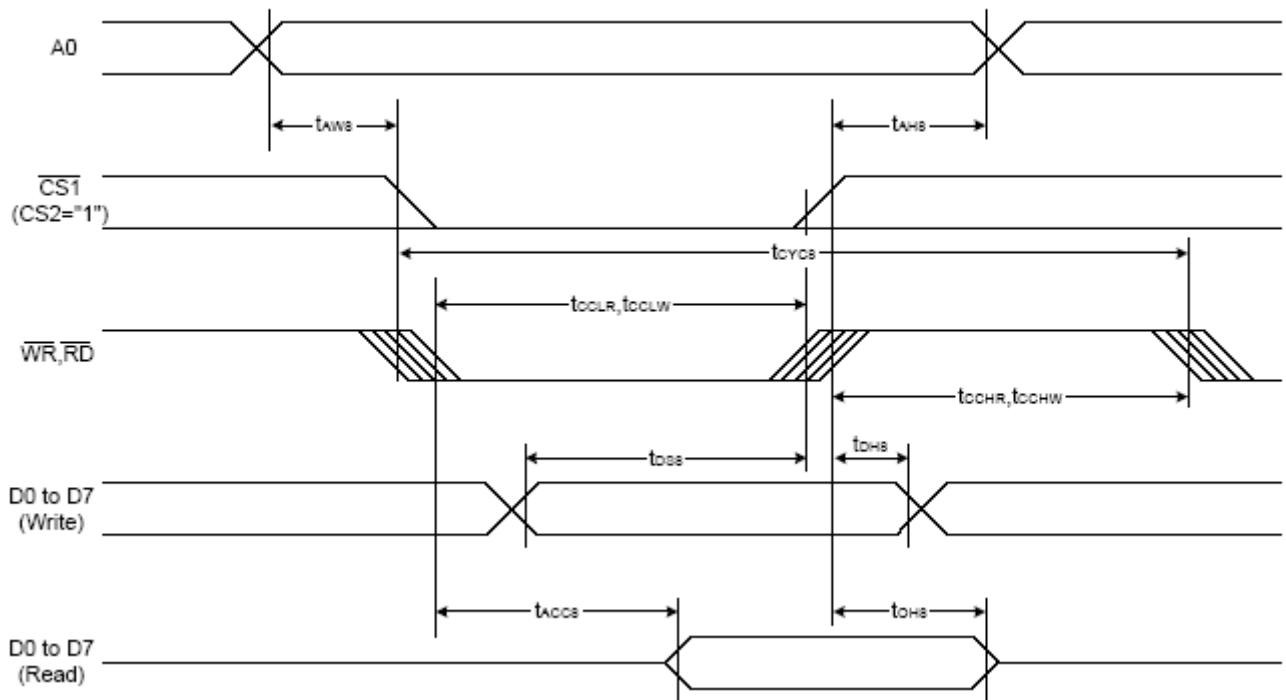

Item	Signal	Symbol	Condition	Rating		Units
				Min.	Max.	
Address hold time	A0	tAHS		0	—	Ns
Address setup time		tAWs		0	—	
System cycle time		tCYCs		240	—	
Enable L pulse width (WRITE)	WR	tOCLW		80	—	
Enable H pulse width (WRITE)		tOCHW		80	—	
Enable L pulse width (READ)	RD	tOCLR		140	—	
Enable H pulse width (READ)		tOCHR		80	—	
WRITE Data setup time	D0 to D7	tDSs		40	—	
WRITE Address hold time		tDHS		0	—	
READ access time		tACCs	CL = 100 pF	—	70	
READ Output disable time		tOHS	CL = 100 pF	5	50	

System Bus Read/Write Characteristics 2 (For the 6800 Series MPU)

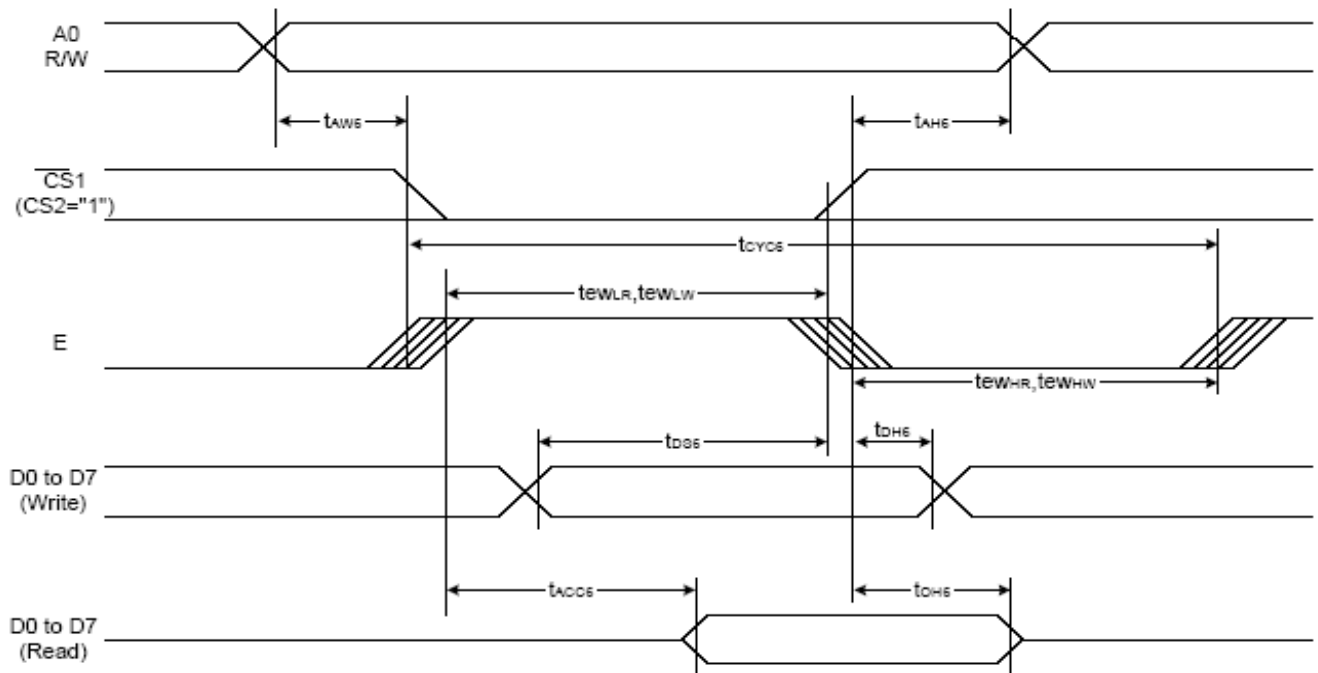

Item	Signal	Symbol	Condition	Rating		Units
				Min.	Max.	
Address hold time	A0	tAH6		0	—	ns
Address setup time		tAW6		0	—	
System cycle time		tCYC6		240	—	
Enable L pulse width (WRITE)	WR	tEHLW		80	—	
Enable H pulse width (WRITE)		tEHWL		80	—	
Enable L pulse width (READ)	RD	tEHLR		80	—	
Enable H pulse width (READ)		tEHR		140	—	
WRITE Data setup time	D0 to D7	tDS6		40	—	
WRITE Address hold time		tDH6		0	—	
READ access time		tACC6	CL = 100 pF	—	70	
READ Output disable time		tOH6	CL = 100 pF	5	50	

9. COMMAND TABLE

Command	Command Code								Function				
	A0	/RD	/WR	D7	D6	D5	D4	D3		D2	D1	D0	
(1) Display ON/OFF	0	1	0	1	0	1	0	1	1	1	0	1	LCD display ON/OFF 0: OFF, 1: ON
(2) Display start line set	0	1	0	0	1	Display start address						Sets the display RAM display start line address	
(3) Page address set	0	1	0	1	0	1	1	Page address				Sets the display RAM page address	
(4) Column address set upper bit	0	1	0	0	0	0	1	Most significant column address				Sets the most significant 4 bits of the display RAM column address.	
Column address set lower bit	0	1	0	0	0	0	0	Least significant column address				Sets the least significant 4 bits of the display RAM column address.	
(5) Status read	0	0	1	Status				0	0	0	0	0	Reads the status data
(6) Display data write	1	1	0	Write data								Writes to the display RAM	
(7) Display data read	1	0	1	Read data								Reads from the display RAM	
(8) ADC select	0	1	0	1	0	1	0	0	0	0	0	0	Sets the display RAM address SEG output correspondence 0: normal, 1: reverse
(9) Display normal/reverse	0	1	0	1	0	1	0	0	1	1	0	1	Sets the LCD display normal/reverse 0: normal, 1: reverse
(10) Display all points ON/OFF	0	1	0	1	0	1	0	0	1	0	0	1	Display all points 0: normal display 1: all points ON
(11) LCD bias set	0	1	0	1	0	1	0	0	0	1	0	1	Sets the LCD drive voltage bias ratio 0: 1/9 bias, 1: 1/7 bias (ST7565P)
(12) Read/modify/write	0	1	0	1	1	1	0	0	0	0	0	0	Column address increment At write: +1 At read: 0
(13) End	0	1	0	1	1	1	0	1	1	1	0	0	Clear read/modify/write
(14) Reset	0	1	0	1	1	1	0	0	0	1	0	0	Internal reset
(15) Common output mode select	0	1	0	1	1	0	0	0	1	*	*	*	Select COM output scan direction 0: normal direction 1: reverse direction
(16) Power control set	0	1	0	0	0	1	0	1	Operating mode			Select internal power supply operating mode	
(17) V ₀ voltage regulator internal resistor ratio set	0	1	0	0	0	1	0	0	Resistor ratio			Select internal resistor ratio(R _b /R _a) mode	
(18) Electronic volume mode set	0	1	0	1	0	0	0	0	0	0	0	1	Set the V ₀ output voltage electronic volume register
Electronic volume register set				0	0	Electronic volume value							
(19) Static indicator ON/OFF	0	1	0	1	0	1	0	1	1	0	0	0	0: OFF, 1: ON
Static indicator register set				0	0	0	0	0	0	0	0	1	Mode
(20) Booster ratio set	0	1	0	1	1	1	1	1	0	0	0	0	select booster ratio 00: 2x,3x,4x 01: 5x 11: 6x
(21) Power saver													Display OFF and display all points ON compound command
(22) NOP	0	1	0	1	1	1	0	0	0	1	1	1	Command for non-operation
(23) Test	0	1	0	1	1	1	1	*	*	*	*	*	Command for IC test. Do not use this command

10. MODULE ACCEPT QUALITY LEVEL (AQL)

10.1 AQL Standard Value: Critical Defect =0.1, Major Defect=0.65; Minor Defect =2.5.

10.2 Inspection Standard: MIL-STD-105E Table Normal Inspection Single Sampling Level II .

11. RELIABILITY TEST

Operating life time: 50000 hours (at room temperature without direct irradiation of sunlight)

Reliability characteristics shall meet following requirements.

TEMPERATURE TESTS	NORMAL GRADE
High temperature storage	+90□ x 96hrs
Low temperature storage	-40□ x 96hrs
High temperature operation	+80□ x 96hrs
Low temperature operation	-30□ x 96hrs
High temperature, High humidity	+60□ x 90%RH x 96hrs
Thermal shock	0□ x 30min → 25□ x 30min → +60□ x 30min 5 Cycles
Vibration test	Frequency x Swing x Time 40Hz x 4mm x 4hrs
Drop test	Height x no. of drop 1.0m x 6 drops

12. QUALITY DESCRIPTION

DEFECT SPECIFICATION:

a: Table for Cosmetic defects
 (Note: nc = not counted).
 Sizes and number of defects
 (Max. Qty)

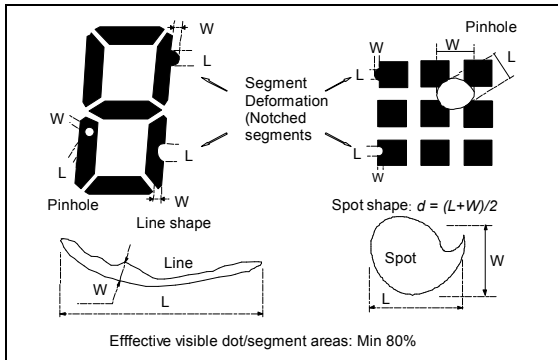

Examples/ Shapes

b: Glass defects

b1: Glass defects at contact ledge

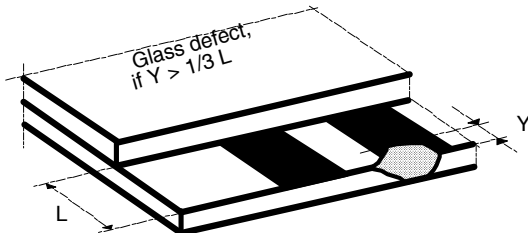

b2: Glass chipping in other areas shall not be in conflict with the product's function.

Defect Type	Max. defect size [μm]dorL W	Max. Quantity.
Black or White Spots	$d \leq 150$	Nc
	$150 < d \leq 300$	3
Black or White Lines	$W \leq 10$	Nc
	$L \leq 3000$ $W \leq 30$	2
	$L \leq 2000$ $W \leq 50$	2
Pinhole	$d \leq 150$	nc
	$150 < d \leq 300$	1/segment
(Total defects)		(5)
Segment Deformation	$W \leq 100$	Nc
Bubble (e.g. under pola)	$d \leq 150$	Nc
	$200 < d \leq 400$	2

13. LCD MODULES HANDLING PRECAUTIONS

- The display panel is made of glass. Do not subject it to a mechanical shock by dropping it from a high place, etc.
- If the display panel is damaged and the liquid crystal substance inside it leaks out, do not get any in your mouth. If the substance come into contact with your skin or clothes promptly wash it off using soap and water.
- Do not apply excessive force to the display surface or the adjoining areas since this may cause the color tone to vary.
- The polarizer covering the display surface of the LCD module is soft and easily scratched. Handle this polarize carefully.
- To prevent destruction of the elements by static electricity, be careful to maintain an optimum work environment.
 - Be sure to ground the body when handling the LCD module.
 - Tools required for assembly, such as soldering irons, must be properly grounded.
 - To reduce the amount of static electricity generated, do not conduct assembly and other work under dry conditions.
 - The LCD module is coated with a film to protect the display surface. Exercise care when peeling off this protective film since static electricity may be generated.
- Storage precautions
When storing the LCD modules, avoid exposure to direct sunlight or to the light of fluorescent lamps. Keep the modules in bags designed to prevent static electricity charging under low temperature / normal humidity conditions (avoid high temperature / high humidity and low temperatures below 0□). Whenever possible, the LCD modules should be stored in the same conditions in which they were shipped from our company.

14. OTHERS

- Liquid crystals solidify at low temperature (below the storage temperature range) leading to defective orientation of liquid crystal or the generation of air bubbles (black or white). Air bubbles may also be generated if the module is subjected to a strong shock at a low temperature.
- If the LCD modules have been operating for a long time showing the same display patterns may remain on the screen as ghost images and a slight contrast irregularity may also appear. Abnormal operating status can be resumed to be normal condition by suspending use for some time. It should be noted that this phenomena does not adversely affect performance reliability.
- To minimize the performance degradation of the LCD modules resulting from caused by static electricity, etc. exercise care to avoid holding the following sections when handling the modules :
 - Exposed area of the printed circuit board
 - Terminal electrode sections