

NEW

DRS61: Incremental encoders, number of lines and zero pulse width freely programmable

DRS60: Incremental Encoders with Zero-Pulse-Teach



Further highlights of this generation of encoders:

- Simple zero-pulse-teach by pressing a button located under a cap on the rear of the encoder
- Excellent price/performance ratio
- Long LED lifetime as a result of automatic light regulation
- Maximum reliability as a result of opto-ASICs with Chip-on-Board technology
- Interchangeable collets for hollow shaft diameters from 6 to 15 mm and 1/4, 3/8, 1/2 inch.

	Number of lines
	1 up to 8,192
Incremental Encoder	

CoreTech[®]
by **SICK** | **STEGMANN**

C

CoreTech technology permits tailor-made solutions for every application, due to its modular design.

With DRS61 incremental encoders, the number of lines from 1 to 8,192 and the width of the zero pulse can be freely programmed **by the customer**. Therefore, they will be of particular interest to end users, distributors, consulting engineers and system integrators.

DRS60 incremental encoders are available with any desired number of lines between 1 and 8,192.

Whether with face mount flange, servo flange, blind or through hollow shaft with connector or cable outlet, TTL or HTL interface – DRS60/61 encoders will meet virtually any application profile.

Thanks to this wide variety of products, there are numerous possible uses, for example in:

- machine tools
- textile machines
- woodworking machines
- packaging machines

SICK | STEGMANN

Number of lines
1 up to 8,192

Incremental Encoder

- Connector or cable outlet
- Protection class up to IP 66
- Electrical interfaces
TTL and HTL
- Zero-Pulse-Teach via pressing a button
- DRS61: number of lines and zero pulse width can be freely programmed by the customer

Dimensional drawing face mount flange radial

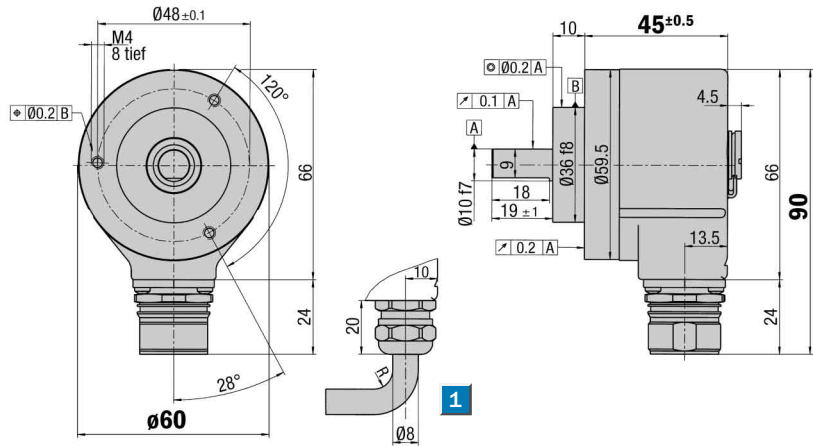

1 R = bending radius min. 40 mm General tolerances according to DIN ISO 2768-mk

Dimensional drawing face mount flange axial

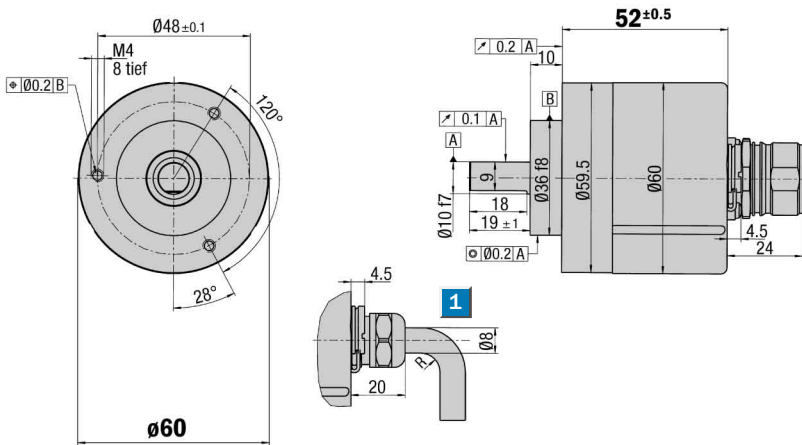

1 R = bending radius min. 40 mm General tolerances according to DIN ISO 2768-mk



PIN and wire allocation/cable 11 core

PIN	Signal	Wire colour (Cable outlet)	Explanation
1	\bar{B}	black	Signal line
2	Sense +	grey	Connected internally to U_s
3	Z	lilac	Signal line
4	\bar{Z}	yellow	Signal line
5	A	white	Signal line
6	\bar{A}	brown	Signal line
7	N. C.	orange	Not connected
8	B	pink	Signal line
9	Screen		Housing potential
10	GND	blue	Zero volt connected to the encoder
11	Sense -	green	Connected internally to GND
12	U_s	red	Supply voltage ¹⁾

Accessories
Connection systems
Mounting systems
Programming Tool

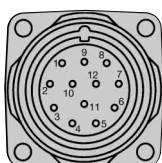

View of the connector M23 fitted to the encoder body

¹⁾ Potential free to housing
 N. C. =
 Not connected

Technical Data acc. to DIN 32878		DRS60/DRS61 face mount flange	Flange type							
			face m.							
Solid shaft	10 mm									
Number of lines per revolution	00001 up to 08192, see order info									
Electrical Interface	TTL/RS 422, 6-channel									
	HTL/push-pull, 6-channel									
Mass ¹⁾	Approx. 0.3 kg									
Moment of inertia of the rotor	54 gcm ²									
Measuring step	90°/number of lines									
Reference signal										
Number	1									
Position ²⁾	90° or 180°									
Error limits										
binary number of lines	0.035°									
non-binary number of lines	0.046°									
Measuring step deviation										
binary number of lines	0.005°									
non-binary number of lines	0.016°									
Max. output frequency										
TTL	820 kHz									
HTL	200 kHz									
Operating torque max.										
with shaft seal	6,000 min ⁻¹									
without shaft seal ³⁾	10,000 min ⁻¹									
Max. angular acceleration	5 x 10 ⁵ rad/s ²									
Operating torque	Typ. 0.3 Ncm									
Start up torque	Typ. 0.4 Ncm									
Permissible shaft loading										
radial	20 N									
axial	10 N									
Bearing lifetime	3.6 x 10 ⁹ revolutions									
Working temperature range	- 20 ... + 85 °C									
Storage temperature range	- 40 ... + 100 °C									
Permissible relative humidity ⁴⁾	90 %									
EMC ⁵⁾										
Resistance										
to shocks ⁶⁾	50/11 g/ms									
to vibration ⁷⁾	20/10 ... 2000 g/Hz									
Protection class IEC 60529										
Connector outlet ⁸⁾	IP 65									
Cable outlet	IP 66									
Operating voltage range										
Load current TTL/RS 422, 4.5 ... 5.5 V Max. 20 mA										
TTL/RS 422, 10 ... 32 V Max. 20 mA										
HTL/push-pull, 10 ... 32 V Max. 60 mA										
No-load operating current										
at 10 ... 32 V	Typ. 100 mA									
at 5 V	Typ. 120 mA									
Operation of zero-set ⁹⁾	≥ 100 ms									
Initialisation time after power on	40 ms									

¹⁾ Concerning encoder with connector

²⁾ Electrical, logically linked to A and B

³⁾ In case, that shaft seal has been removed by customer

⁴⁾ Condensation of the optical scanning not permitted

⁵⁾ To DIN EN 61000-6-2 and DIN EN 61000-6-3

⁶⁾ To DIN EN 60068-2-27

⁷⁾ To DIN EN 60068-2-6

⁸⁾ With mating connector fitted

⁹⁾ Only with shaft stationary

Number of lines
1 up to 8,192

Incremental Encoder

- Connector or cable outlet
- Protection class up to IP 66
- Electrical interfaces
 TTL and HTL
- Zero-Pulse-Teach via pressing a button
- DRS61: number of lines and zero pulse width can be freely programmed by the customer



Incremental pulse diagram

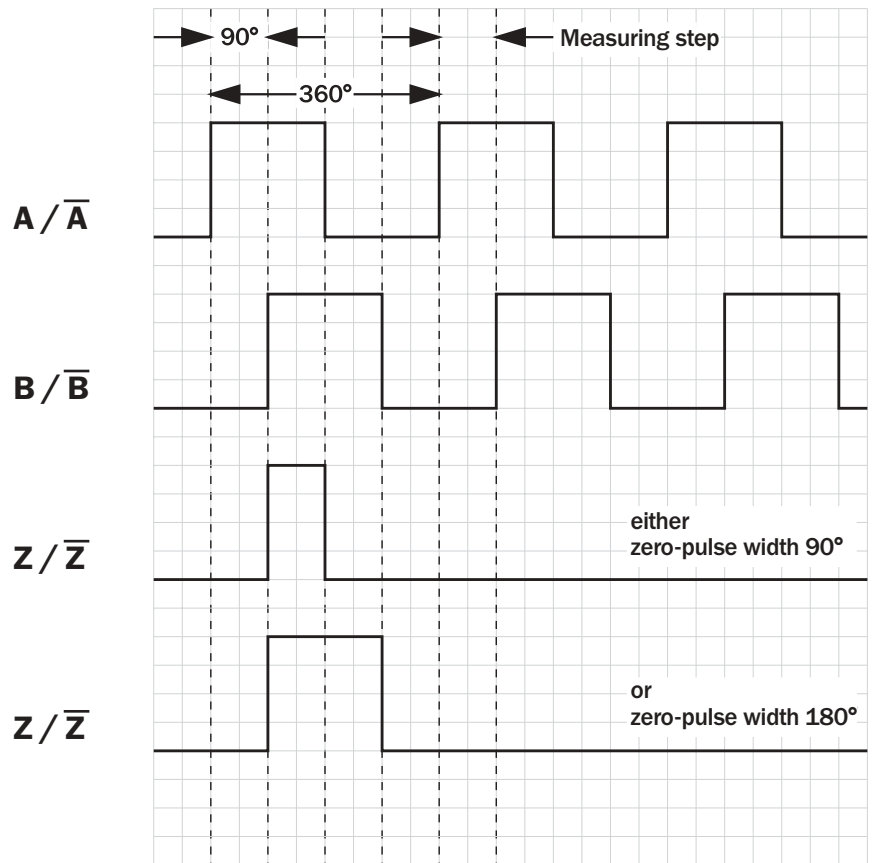

Electrical interface

Supply voltage	4.5 ... 5.5 V	10 ... 32 V	10 ... 32 V
Interfaces/drivers	TTL (RS 422)	TTL (RS 422)	HTL (push-pull)

Connection type

Cable radial	Cable axial	Connector radial	Connector axial
--------------	-------------	------------------	-----------------

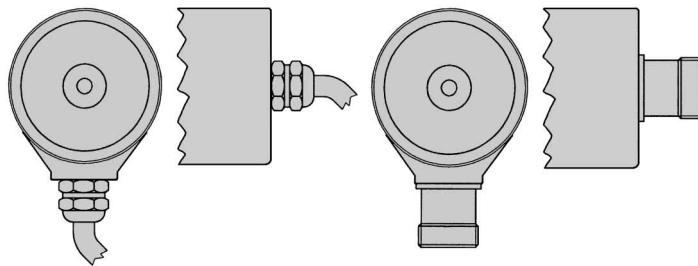

Accessories

Connection systems
Mounting systems
Programming Tool



Order information

Incremental Encoder DRS60, face mount flange, solid shaft

Point 1	Point 2	Point 3	Point 4	Point 5	Point 6	Point 7	Point 8	Point 9	Point 10	Point 11	Point 12	Point 13	Point 14
D	R	S	6	0	-		4						

Electrical interface	Mechanical interface	Connection type	Number of lines
4.5 ... 5.5 V, TTL/RS 422 Zero-pulse width 90° = A	Face mount flange, solid shaft 10 mm = 4	Connector M23, 12 pin, radial = A	Each number of lines from 00001 up to 08192 possible. Always 5 characters in clear text.
4.5 ... 5.5 V, TTL/RS 422 Zero-pulse width 180° = B		Connector M23, 12 pin, axial = B	
10 ... 32 V, TTL/RS 422 Zero-pulse width 90° = C		Cable 11 core, radial 1.5 m = K	
10 ... 32 V, TTL/RS 422 Zero-pulse width 180° = D		Cable 11 core, radial 3 m = L	
10 ... 32 V, TTL/RS 422 Zero-pulse width 90° = E		Cable 11 core, radial 5 m = M	
10 ... 32 V, TTL/RS 422 Zero-pulse width 180° = F		Cable 11 core, radial 10 m = N	
		Cable 11 core, axial 1.5 m = R	
		Cable 11 core, axial 3 m = S	
		Cable 11 core, axial 5 m = T	
		Cable 11 core, axial 10 m = U	

Order example Incremental Encoder DRS60

4.5 ... 5.5 V, TTL/RS 422 zero-pulse width 90°; face mount flange; connector M23, 12 pin, radial; number of lines: 360

Point 1	Point 2	Point 3	Point 4	Point 5	Point 6	Point 7	Point 8	Point 9	Point 10	Point 11	Point 12	Point 13	Point 14
D	R	S	6	0	-	A	4	A	0	0	3	6	0



Incremental-Encoder DRS61 face mount flange, solid shaft (number of lines and zero pulse width can be freely programmed by the customer) ¹

Point 1	Point 2	Point 3	Point 4	Point 5	Point 6	Point 7	Point 8	Point 9	Point 10	Point 11	Point 12	Point 13	Point 14
D	R	S	6	1	-		4		0	8	1	9	2

Electrical interface	Mechanical interface	Connection type	Number of lines
4.5 ... 5.5 V, TTL/RS 422 = A	Face mount flange, solid shaft 10 mm = 4	Connector M23, 12 pin, radial = A	Factory-programmed to 8,192.
10 ... 32 V, TTL/RS 422 = C		Connector M23, 12 pin, axial = B	
10 ... 32 V, HTL/push-pull = E		Cable 11 core, radial 1.5 m = K	
		Cable 11 core, axial 1.5 m = R	

Order example Incremental Encoder DRS61

4.5 ... 5.5 Volt, TTL/RS 422; face mount flange; connector M23, 12 pin, radial; number of lines: 8,192 (factory-programmed)

Point 1	Point 2	Point 3	Point 4	Point 5	Point 6	Point 7	Point 8	Point 9	Point 10	Point 11	Point 12	Point 13	Point 14
D	R	S	6	1	-	A	4	A	0	8	1	9	2

¹ Please order programming tool separately (see accessories page 18)

Number of lines
1 up to 8,192

Incremental Encoder

- Connector or cable outlet
- Protection class up to IP 66
- Electrical interfaces
TTL and HTL
- Zero-Pulse-Teach via
pressing a button
- DRS61: number of lines and
zero pulse width can be freely
programmed by the customer

Dimensional drawing servo flange radial

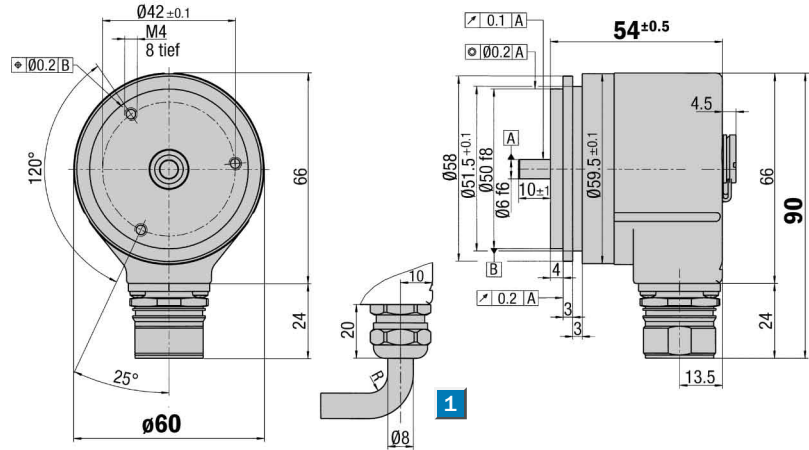

1 R = bending radius min. 40 mm

General tolerances according to DIN ISO 2768-mk

Dimensional drawing servo flange axial

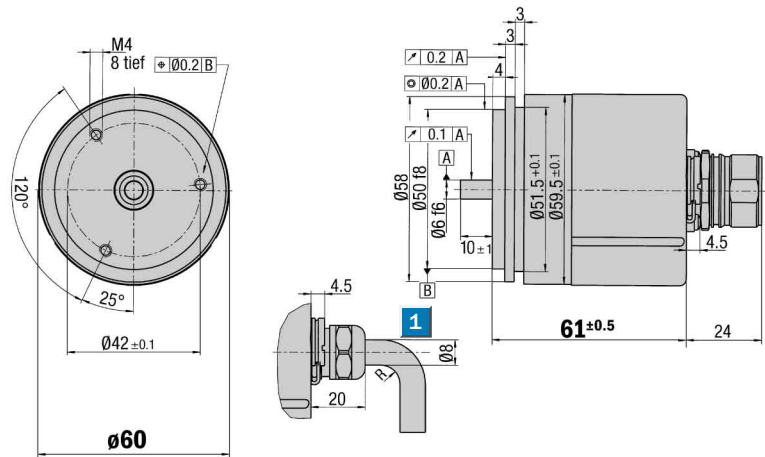

1 R = bending radius min. 40 mm

General tolerances according to DIN ISO 2768-mk

PIN and wire allocation/cable 11 core

PIN	Signal	Wire colour (Cable outlet)	Explanation
1	\bar{B}	black	Signal line
2	Sense +	grey	Connected internally to U_s
3	Z	lilac	Signal line
4	\bar{Z}	yellow	Signal line
5	A	white	Signal line
6	\bar{A}	brown	Signal line
7	N. C.	orange	Not connected
8	B	pink	Signal line
9	Screen		Housing potential
10	GND	blue	Zero volt connected to the encoder
11	Sense -	green	Connected internally to GND
12	U_s	red	Supply voltage ¹⁾

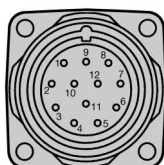

View of the connector M23 fitted to the encoder body

¹⁾ Potential free to housing
N. C. =
Not connected



Accessories

- Connection systems
- Mounting systems
- Programming Tool

Technical Data acc. to DIN 32878		DRS60/DRS61 servo flange	Flange type											
			servo											
Solid shaft	6 mm													
Number of lines per revolution	00001 up to 08192, see order info													
Electrical Interface	TTL/RS 422, 6-channel													
	HTL/push-pull, 6-channel													
Mass ¹⁾	Approx. 0.3 kg													
Moment of inertia of the rotor	48 gcm ²													
Measuring step	90°/number of lines													
Reference signal														
Number	1													
Position ²⁾	90° or 180°													
Error limits														
binary number of lines	0.035°													
non-binary number of lines	0.046°													
Measuring step deviation														
binary number of lines	0.005°													
non-binary number of lines	0.016°													
Max. output frequency														
TTL	820 kHz													
HTL	200 kHz													
Operating torque max.														
with shaft seal	6,000 min ⁻¹													
without shaft seal ³⁾	10,000 min ⁻¹													
Max. angular acceleration	5 x 10 ⁵ rad/s ²													
Operating torque	Typ. 0.2 Ncm													
Start up torque	Typ. 0.25 Ncm													
Permissible shaft loading														
radial	20 N													
axial	10 N													
Bearing lifetime	3.6 x 10 ⁹ revolutions													
Working temperature range	- 20 ... + 85 °C													
Storage temperature range	- 40 ... + 100 °C													
Permissible relative humidity ⁴⁾	90 %													
EMC ⁵⁾														
Resistance														
to shocks ⁶⁾	50/11 g/ms													
to vibration ⁷⁾	20/10 ... 2000 g/Hz													
Protection class IEC 60529														
Connector outlet ⁸⁾	IP 65													
Cable outlet	IP 66													
Operating voltage range														
Load current TTL/RS 422, 4.5 ... 5.5 V Max. 20 mA														
TTL/RS 422, 10 ... 32 V Max. 20 mA														
HTL/push-pull, 10 ... 32 V Max. 60 mA														
No-load operating current														
at 10 ... 32 V	Typ. 100 mA													
at 5 V	Typ. 120 mA													
Operation of zero-set ⁹⁾	≥ 100 ms													
Initialisation time after power on	40 ms													

¹⁾ Concerning encoder with connector²⁾ Electrical, logically linked to A and B³⁾ In case, that shaft seal has been removed by customer⁴⁾ Condensation of the optical scanning not permitted⁵⁾ To DIN EN 61000-6-2 and DIN EN 61000-6-3⁶⁾ To DIN EN 60068-2-27⁷⁾ To DIN EN 60068-2-6⁸⁾ With mating connector fitted⁹⁾ Only with shaft stationary

Number of lines
1 up to 8,192

Incremental Encoder

- Connector or cable outlet
- Protection class up to IP 66
- Electrical interfaces
TTL and HTL
- Zero-Pulse-Teach via pressing a button
- DRS61: number of lines and zero pulse width can be freely programmed by the customer



Incremental pulse diagram

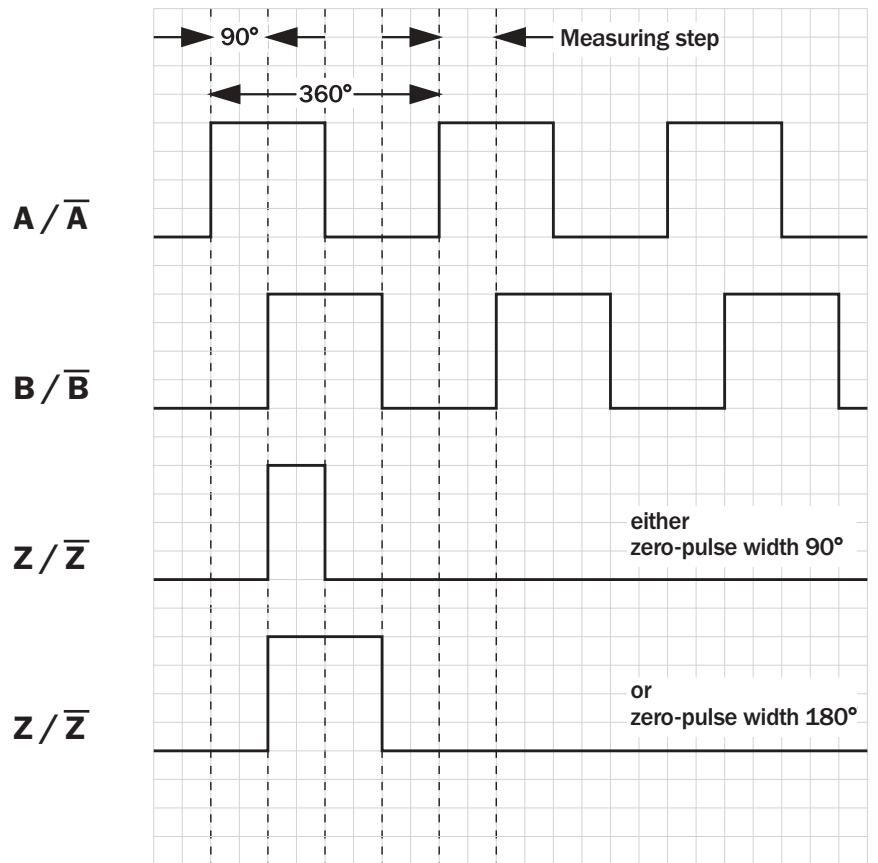

Electrical interface

Supply voltage	4.5 ... 5.5 V	10 ... 32 V	10 ... 32 V
Interfaces/drivers	TTL (RS 422)	TTL (RS 422)	HTL (push-pull)

Connection type

Cable radial	Cable axial	Connector radial	Connector axial
--------------	-------------	------------------	-----------------

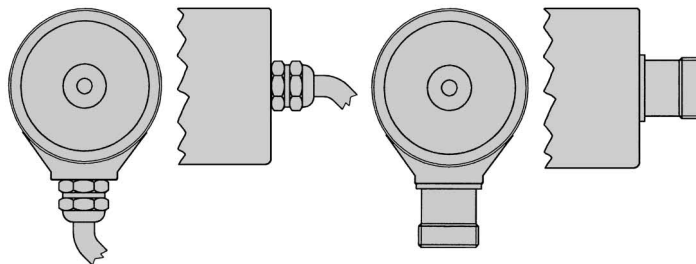

Accessories

- Connection systems
- Mounting systems
- Programming Tool



Order information

Incremental Encoder DRS60, servo flange, solid shaft

Point 1	Point 2	Point 3	Point 4	Point 5	Point 6	Point 7	Point 8	Point 9	Point 10	Point 11	Point 12	Point 13	Point 14
D	R	S	6	0	-		1						

<p>Electrical interface</p> <p>4.5 ... 5.5 V, TTL/RS 422 Zero-pulse width 90° = A</p> <p>4.5 ... 5.5 V, TTL/RS 422 Zero-pulse width 180° = B</p> <p>10 ... 32 V, TTL/RS 422 Zero-pulse width 90° = C</p> <p>10 ... 32 V, TTL/RS 422 Zero-pulse width 180° = D</p> <p>10 ... 32 V, HTL/push-pull Zero-pulse width 90° = E</p> <p>10 ... 32 V, HTL/push-pull Zero-pulse width 180° = F</p>	<p>Mechanical interface</p> <p>Servo flange, solid shaft 6 mm = 1</p>	<p>Connection type</p> <p>Connector M23, 12 pin, radial = A</p> <p>Connector M23, 12 pin, axial = B</p> <p>Cable 11 core, radial 1.5 m = K</p> <p>Cable 11 core, radial 3 m = L</p> <p>Cable 11 core, radial 5 m = M</p> <p>Cable 11 core, radial 10 m = N</p> <p>Cable 11 core, axial 1.5 m = R</p> <p>Cable 11 core, axial 3 m = S</p> <p>Cable 11 core, axial 5 m = T</p> <p>Cable 11 core, axial 10 m = U</p>	<p>Number of lines</p> <p>Each number of lines from 00001 up to 08192 possible. Always 5 characters in clear text.</p>
---	---	--	---

Order example Incremental Encoder DRS60

4.5 ... 5.5 V, TTL/RS 422 zero-pulse width 90°; servo flange; connector M23, 12 pin, radial; number of lines: 360

Point 1	Point 2	Point 3	Point 4	Point 5	Point 6	Point 7	Point 8	Point 9	Point 10	Point 11	Point 12	Point 13	Point 14
D	R	S	6	0	-	A	1	A	0	0	3	6	0



Incremental-Encoder DRS61, servo flange, solid shaft (number of lines and zero pulse width can be freely programmed by the customer) ¹

Point 1	Point 2	Point 3	Point 4	Point 5	Point 6	Point 7	Point 8	Point 9	Point 10	Point 11	Point 12	Point 13	Point 14
D	R	S	6	1	-		1		0	8	1	9	2

<p>Electrical interface</p> <p>4.5 ... 5.5 V, TTL/RS 422 = A</p> <p>10 ... 32 V, TTL/RS 422 = C</p> <p>10 ... 32 V, HTL/push-pull = E</p>	<p>Mechanical interface</p> <p>Servo flange, solid shaft 6 mm = 1</p>	<p>Connection type</p> <p>Connector M23, 12 pin, radial = A</p> <p>Connector M23, 12 pin, axial = B</p> <p>Cable 11 core, radial 1.5 m = K</p> <p>Cable 11 core, axial 1.5 m = R</p>	<p>Number of lines</p> <p>Factory-programmed to 8,192.</p>
---	---	---	---

Order example Incremental Encoder DRS61

4.5 ... 5.5 Volt, TTL/RS 422; servo flange; connector M23, 12 pin, radial; number of lines: 8,192 (factory-programmed)

Point 1	Point 2	Point 3	Point 4	Point 5	Point 6	Point 7	Point 8	Point 9	Point 10	Point 11	Point 12	Point 13	Point 14
D	R	S	6	1	-	A	1	A	0	8	1	9	2

¹ Please order programming tool separately (see accessories page 18)

Number of lines
1 up to 8,192

Incremental Encoder

- Connector or cable outlet
- Protection class up to IP 66
- Electrical interfaces
TTL and HTL
- Zero-Pulse-Teach via
pressing a button
- DRS61: number of lines and
zero pulse width can be freely
programmed by the customer

Dimensional drawing blind hollow shaft radial

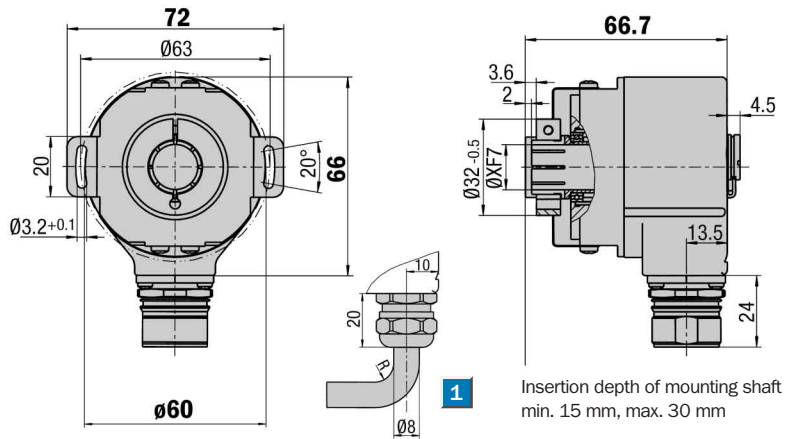

1 R = bending radius min. 40 mm General tolerances according to DIN ISO 2768-mk

Dimensional drawing blind hollow shaft axial

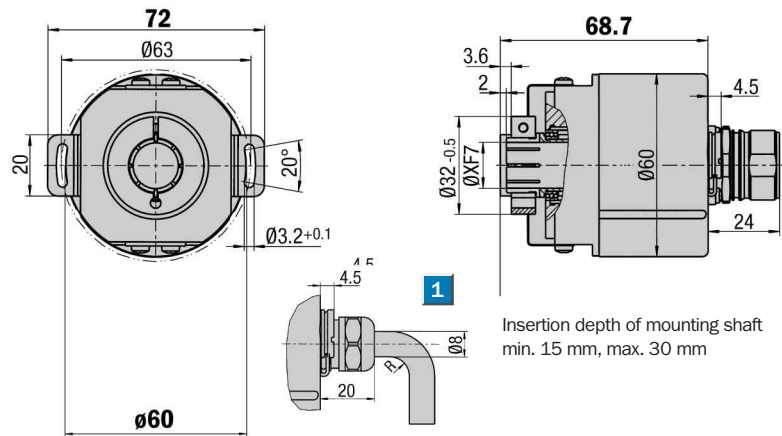

1 R = bending radius min. 40 mm General tolerances according to DIN ISO 2768-mk

PIN and wire allocation/cable 11 core

PIN	Signal	Wire colour (Cable outlet)	Explanation
1	\bar{B}	black	Signal line
2	Sense +	grey	Connected internally to U_s
3	Z	lilac	Signal line
4	\bar{Z}	yellow	Signal line
5	A	white	Signal line
6	\bar{A}	brown	Signal line
7	N. C.	orange	Not connected
8	B	pink	Signal line
9	Screen		Housing potential
10	GND	blue	Zero volt connected to the encoder
11	Sense -	green	Connected internally to GND
12	U_s	red	Supply voltage ¹⁾

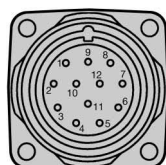

View of the connector M23 fitted to the encoder body

¹⁾ Potential free to housing
 N. C. =
 Not connected

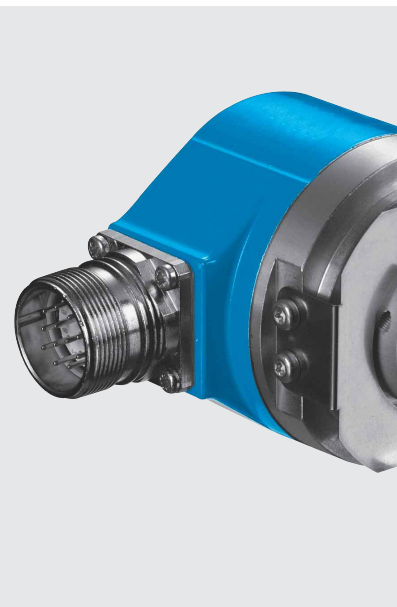

Accessories

Connection systems
Mounting systems
Collets
Programming Tool

Technical Data acc. to DIN 32878		DRS60/DRS61 blind hollow shaft		Flange type					
		blind							
Hollow shaft diameter	6, 8, 10, 12, 15 mm, 1/4", 3/8", 1/2"								
Number of lines per revolution	00001 up to 08192, see order info								
Electrical Interface	TTL/RS 422, 6-channel								
	HTL/push-pull, 6-channel								
Mass ¹⁾	Approx. 0.3 kg								
Moment of inertia of the rotor	See Fig. 1								
Measuring step	90°/number of lines								
Reference signal									
Number	1								
Position ²⁾	90° or 180°								
Error limits									
binary number of lines	0.035°								
non-binary number of lines	0.046°								
Measuring step deviation									
binary number of lines	0.005°								
non-binary number of lines	0.016°								
Max. output frequency									
TTL	820 kHz								
HTL	200 kHz								
Operating torque max.	3,000 min ⁻¹								
Max. angular acceleration	5 x 10 ⁵ rad/s ²								
Operating torque	Typ. 0.4 Ncm								
Start up torque	Typ. 0.6 Ncm								
Permissible movement of the drive element									
radial static/dynamic movement	± 0.3/± 0.1 mm								
axial static/dynamic movement	± 0.5/± 0.2 mm								
Bearing lifetime	3.6 x 10 ⁹ revolutions								
Working temperature range	- 20 ... + 85 °C								
Storage temperature range	- 40 ... + 100 °C								
Permissible relative humidity ³⁾	90 %								
EMC ⁴⁾									
Resistance									
to shocks ⁵⁾	50/11 g/ms								
to vibration ⁶⁾	20/10 ... 2000 g/Hz								
Protection class IEC 60529									
Connector outlet ⁷⁾	IP 65								
Cable outlet	IP 66								
Operating voltage range									
Load current TTL/RS 422, 4.5 ... 5.5 V Max. 20 mA									
TTL/RS 422, 10 ... 32 V Max. 20 mA									
HTL/push-pull, 10 ... 32 V Max. 60 mA									
No-load operating current									
at 10 ... 32 V	Typ. 100 mA								
at 5 V	Typ. 120 mA								
Operation of zero-set ⁸⁾	≥ 100 ms								
Initialisation time after power on	40 ms								

¹⁾ Concerning encoder with connector

²⁾ Electrical, logically linked to A and B

³⁾ Condensation of the optical scanning not permitted

⁴⁾ To DIN EN 61000-6-2 and DIN EN 61000-6-3

⁵⁾ To DIN EN 60068-2-27

⁶⁾ To DIN EN 60068-2-6

⁷⁾ With mating connector fitted

⁸⁾ Only with shaft stationary

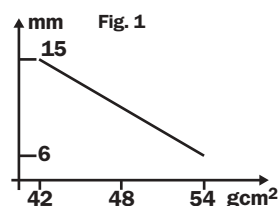

Number of lines
1 up to 8,192

Incremental Encoder

- Connector or cable outlet
- Protection class up to IP 66
- Electrical interfaces
TTL and HTL
- Zero-Pulse-Teach via pressing a button
- DRS61: number of lines and zero pulse width can be freely programmed by the customer

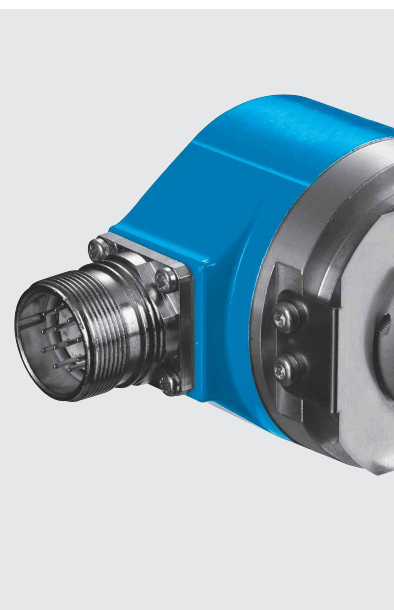

Incremental pulse diagram

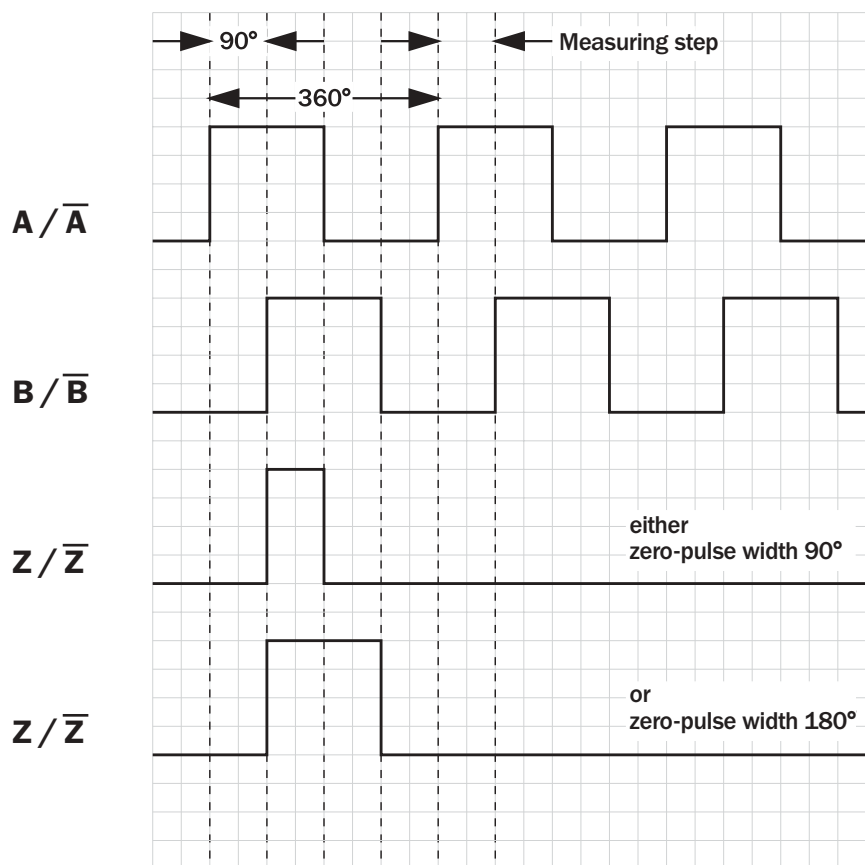

Electrical interface			
Supply voltage	4.5 ... 5.5 V	10 ... 32 V	10 ... 32 V
Interfaces/drivers	TTL (RS 422)	TTL (RS 422)	HTL (push-pull)

Connection type			
Cable radial	Cable axial	Connector radial	Connector axial

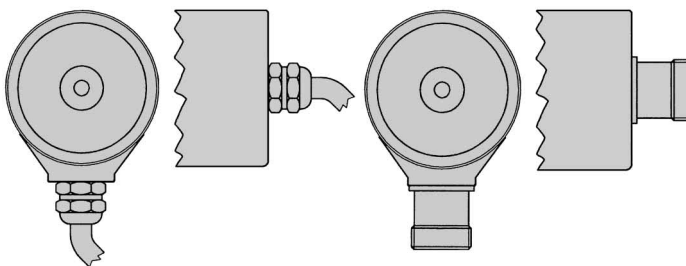

Accessories
Connection systems
Mounting systems
Collets
Programming Tool



Order information

Incremental Encoder DRS60, blind hollow shaft

Point 1	Point 2	Point 3	Point 4	Point 5	Point 6	Point 7	Point 8	Point 9	Point 10	Point 11	Point 12	Point 13	Point 14
D	R	S	6	0	-		A						

<p>Electrical interface</p> <p>4.5 ... 5.5 V, TTL/RS 422 Zero-pulse width 90° = A</p> <p>4.5 ... 5.5 V, TTL/RS 422 Zero-pulse width 180° = B</p> <p>10 ... 32 V, TTL/RS 422 Zero-pulse width 90° = C</p> <p>10 ... 32 V, TTL/RS 422 Zero-pulse width 180° = D</p> <p>10 ... 32 V, HTL/push-pull Zero-pulse width 90° = E</p> <p>10 ... 32 V, HTL/push-pull Zero-pulse width 180° = F</p>	<p>Mechanical interface</p> <p>Blind hollow shaft¹⁾ = A</p> <p>¹⁾ Collets for 6, 8, 10, 12 mm and 1/4", 3/8" and 1/2" as accessories, separate order item (see below). For 15 mm shaft diameter, collet is not needed.</p>	<p>Connection type</p> <p>Connector M23, 12 pin, radial = A</p> <p>Connector M23, 12 pin, axial = B</p> <p>Cable 11 core, radial 1.5 m = K</p> <p>Cable 11 core, radial 3 m = L</p> <p>Cable 11 core, radial 5 m = M</p> <p>Cable 11 core, radial 10 m = N</p> <p>Cable 11 core, axial 1.5 m = R</p> <p>Cable 11 core, axial 3 m = S</p> <p>Cable 11 core, axial 5 m = T</p> <p>Cable 11 core, axial 10 m = U</p>	<p>Number of lines</p> <p>Each number of lines from 00001 up to 08192 possible. Always 5 characters in clear text.</p>
---	--	--	---

Order example Incremental Encoder DRS60

4.5 ... 5.5 V, TTL/RS 422 zero-pulse width 90°; blind hollow shaft; connector M23, 12 pin, radial; number of lines: 360

Point 1	Point 2	Point 3	Point 4	Point 5	Point 6	Point 7	Point 8	Point 9	Point 10	Point 11	Point 12	Point 13	Point 14
D	R	S	6	0	-	A	A	A	0	0	3	6	0



Incremental-Encoder DRS61 blind hollow shaft (number of lines and zero pulse width can be freely programmed by the customer) ¹

Point 1	Point 2	Point 3	Point 4	Point 5	Point 6	Point 7	Point 8	Point 9	Point 10	Point 11	Point 12	Point 13	Point 14
D	R	S	6	1	-		A		0	8	1	9	2

<p>Electrical interface</p> <p>4.5 ... 5.5 V, TTL/RS 422 = A</p> <p>10 ... 32 V, TTL/RS 422 = C</p> <p>10 ... 32 V, HTL/push-pull = E</p>	<p>Mechanical interface</p> <p>Blind hollow shaft¹⁾ = A</p> <p>¹⁾ Collets for 6, 8, 10, 12 mm and 1/4", 3/8" and 1/2" as accessories, separate order item (see below). For 15 mm shaft diameter, collet is not needed.</p>	<p>Connection type</p> <p>Connector M23, 12 pin, radial = A</p> <p>Connector M23, 12 pin, axial = B</p> <p>Cable 11 core, radial 1.5 m = K</p> <p>Cable 11 core, axial 1.5 m = R</p>	<p>Number of lines</p> <p>Factory-programmed to 8,192.</p>
---	--	---	---

Order example Incremental Encoder DRS61

4.5 ... 5.5 Volt, TTL/RS 422; blind hollow shaft; connector M23, 12 pin, radial; number of lines: 8,192 (factory-programmed)

Point 1	Point 2	Point 3	Point 4	Point 5	Point 6	Point 7	Point 8	Point 9	Point 10	Point 11	Point 12	Point 13	Point 14
D	R	S	6	1	-	A	A	A	0	8	1	9	2

¹ Please order programming tool separately (see accessories page 18)

Blind hollow shaft collets

Type	Part no.	Shaft diameter
SPZ-006-AD-A	2029174	6 mm
SPZ-1E4-AD-A	2029175	1/4"
SPZ-008-AD-A	2029176	8 mm
SPZ-3E8-AD-A	2029177	3/8"
SPZ-010-AD-A	2029178	10 mm
SPZ-012-AD-A	2029179	12 mm
SPZ-1E2-AD-A	2029180	1/2"

Dimensional drawing through hollow shaft radial

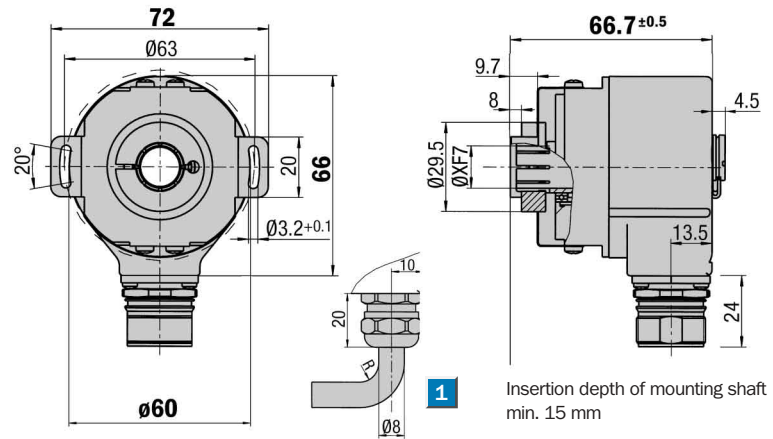

1 R = bending radius min. 40 mm

General tolerances according to DIN ISO 2768-mk

Number of lines
1 up to 8,192

Incremental Encoder

- Connector or cable outlet
- Protection class up to IP 66
- Electrical interfaces
TTL and HTL
- Zero-Pulse-Teach via
pressing a button
- DRS61: number of lines and
zero pulse width can be freely
programmed by the customer

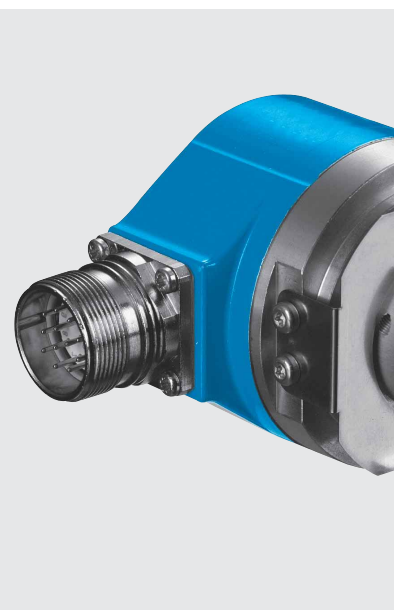

PIN and wire allocation/cable 11 core

PIN	Signal	Wire colour (Cable outlet)	Explanation
1	\bar{B}	black	Signal line
2	Sense +	grey	Connected internally to U_s
3	Z	lilac	Signal line
4	\bar{Z}	yellow	Signal line
5	A	white	Signal line
6	\bar{A}	brown	Signal line
7	N. C.	orange	Not connected
8	B	pink	Signal line
9	Screen		Housing potential
10	GND	blue	Zero volt connected to the encoder
11	Sense -	green	Connected internally to GND
12	U_s	red	Supply voltage ¹⁾

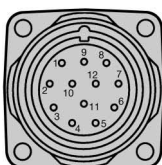

View of the connector M23 fitted to the encoder body

¹⁾ Potential free to housing
N. C. =
Not connected



Accessories

- Connection systems
- Mounting systems
- Collets
- Programming Tool

Technical Data acc. to DIN 32878		DRS60/DRS61 through hollow shaft		Flange type						
				through						
Hollow shaft diameter	6, 8, 10, 12 mm and 1/4", 3/8", 1/2"									
Number of lines per revolution	00001 up to 08192, see order info									
Electrical Interface	TTL/RS 422, 6-channel									
	HTL/push-pull, 6-channel									
Mass ¹⁾	Approx. 0.3 kg									
Moment of inertia of the rotor	See Fig. 1									
Measuring step	90°/number of lines									
Reference signal										
Number	1									
Position ²⁾	90° or 180°									
Error limits										
binary number of lines	0.035°									
non-binary number of lines	0.046°									
Measuring step deviation										
binary number of lines	0.005°									
non-binary number of lines	0.016°									
Max. output frequency										
TTL	820 kHz									
HTL	200 kHz									
Operating torque max.	3,000 min ⁻¹									
Max. angular acceleration	5 x 10 ⁵ rad/s ²									
Operating torque	Typ. 1.6 Ncm									
Start up torque	Typ. 2.2 Ncm									
Permissible movement of the drive element										
radial static/dynamic movement	± 0.3/± 0.1 mm									
axial static/dynamic movement	± 0.5/± 0.2 mm									
Bearing lifetime	3.6 x 10 ⁹ revolutions									
Working temperature range	- 20 ... + 85 °C									
Storage temperature range	- 40 ... + 100 °C									
Permissible relative humidity ³⁾	90 %									
EMC ⁴⁾										
Resistance										
to shocks ⁵⁾	5/11 g/ms									
to vibration ⁶⁾	20/10 ... 2000 g/Hz									
Protection class IEC 60529										
Connector outlet ⁷⁾	IP 64									
Cable outlet	IP 64									
Operating voltage range										
Load current TTL/RS 422, 4.5 ... 5.5 V	Max. 20 mA									
TTL/RS 422, 10 ... 32 V	Max. 20 mA									
HTL/push-pull, 10 ... 32 V	Max. 60 mA									
No-load operating current										
at 10 ... 32 V	Typ. 100 mA									
at 5 V	Typ. 120 mA									
Operation of zero-set ⁸⁾	≥ 100 ms									
Initialisation time after power on	40 ms									

¹⁾ Concerning encoder with connector

²⁾ Electrical, logically linked to A and B

³⁾ Condensation of the optical scanning not permitted

⁴⁾ To DIN EN 61000-6-2 and DIN EN 61000-6-2

⁵⁾ To DIN EN 60068-2-27

⁶⁾ To DIN EN 60068-2-6

⁷⁾ With mating connector fitted

⁸⁾ Only with shaft stationary

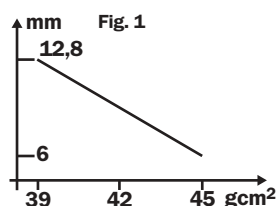

Number of lines
1 up to 8,192

Incremental Encoder

- Connector or cable outlet
- Protection class up to IP 66
- Electrical interfaces
TTL and HTL
- Zero-Pulse-Teach via pressing a button
- DRS61: number of lines and zero pulse width can be freely programmed by the customer

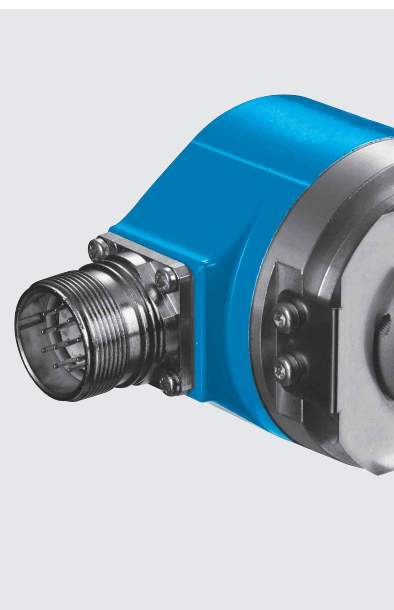

Incremental pulse diagram

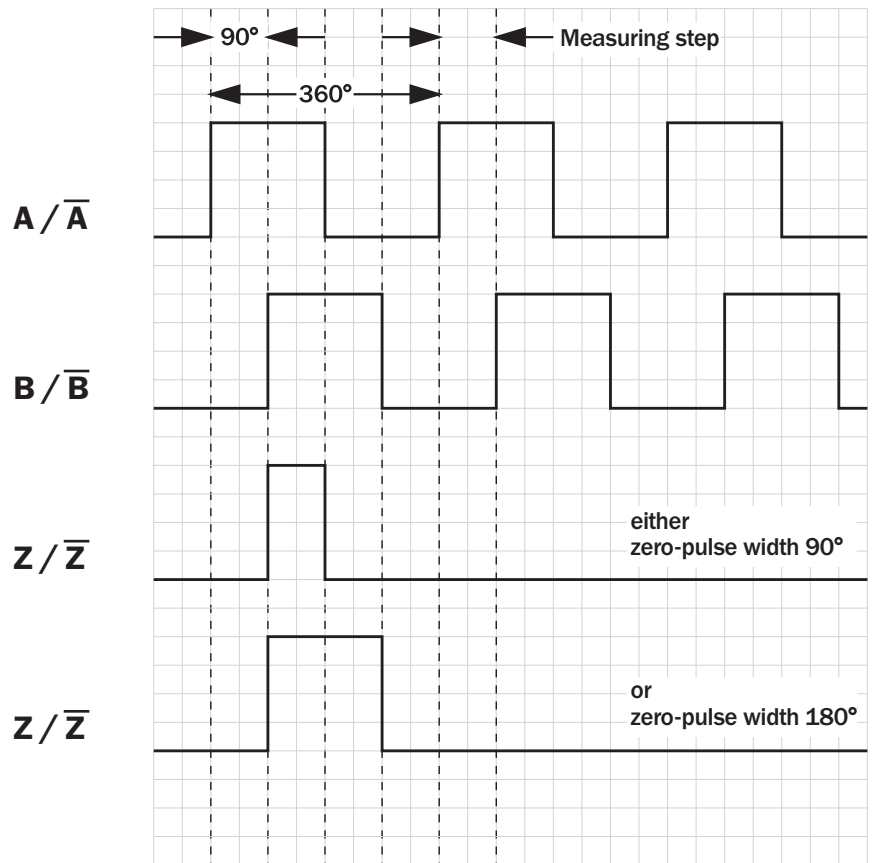

Electrical interface

Supply voltage	4.5 ... 5.5 V	10 ... 32 V	10 ... 32 V
Interfaces/drivers	TTL (RS 422)	TTL (RS 422)	HTL (push-pull)

Connection type

Cable radial

Connector radial

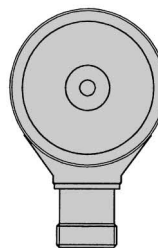
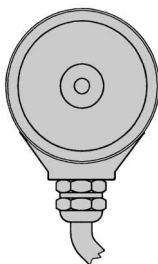

Accessories

- Connection systems
- Mounting systems
- Collets
- Programming Tool



Order information

Incremental Encoder DRS60, through hollow shaft

Point 1	Point 2	Point 3	Point 4	Point 5	Point 6	Point 7	Point 8	Point 9	Point 10	Point 11	Point 12	Point 13	Point 14
D	R	S	6	0	-		D						

Electrical interface 4.5 ... 5.5 V, TTL/RS 422 Zero-pulse width 90° = A 4.5 ... 5.5 V, TTL/RS 422 Zero-pulse width 180° = B 10 ... 32 V, TTL/RS 422 Zero-pulse width 90° = C 10 ... 32 V, TTL/RS 422 Zero-pulse width 180° = D 10 ... 32 V, HTL/push-pull Zero-pulse width 90° = E 10 ... 32 V, HTL/push-pull Zero-pulse width 180° = F	Mechanical interface Through hollow shaft ¹⁾ = D ¹⁾ Collets for 6, 8, 10, 12 mm and 1/4", 3/8" and 1/2" as accessories, separate order item (see below).	Connection type Connector M23, 12 pin, radial = A Cable 11 core, radial 1.5 m = K Cable 11 core, radial 3 m = L Cable 11 core, radial 5 m = M Cable 11 core, radial 10 m = N	Number of lines Each number of lines from 00001 up to 08192 possible. Always 5 characters in clear text.
--	--	---	---

Order example Incremental Encoder DRS60

4.5 ... 5.5 V, TTL/RS 422 zero-pulse width 90°; through hollow shaft; connector M23, 12 pin, radial; number of lines: 360

Point 1	Point 2	Point 3	Point 4	Point 5	Point 6	Point 7	Point 8	Point 9	Point 10	Point 11	Point 12	Point 13	Point 14
D	R	S	6	0	-	A	D	A	0	0	3	6	0



Incremental-Encoder DRS61 through hollow shaft (number of lines and zero pulse width can be freely programmed by the customer) ¹

Point 1	Point 2	Point 3	Point 4	Point 5	Point 6	Point 7	Point 8	Point 9	Point 10	Point 11	Point 12	Point 13	Point 14
D	R	S	6	1	-		D		0	8	1	9	2

Electrical interface 4.5 ... 5.5 V, TTL/RS 422 = A 10 ... 32 V, TTL/RS 422 = C 10 ... 32 V, HTL/push-pull = E	Mechanical interface Through hollow shaft ¹⁾ = D ¹⁾ Collets for 6, 8, 10, 12 mm and 1/4", 3/8" and 1/2" as accessories, separate order item (see below).	Connection type Connector M23, 12 pin, radial = A Cable 11 core, radial 1.5 m = K	Number of lines Factory-programmed to 8,192.
--	--	--	--

Order example Incremental Encoder DRS61

4.5 ... 5.5 Volt, TTL/RS 422; through hollow shaft; connector M23, 12 pin, radial; number of lines: 8,192 (factory-programmed)

Point 1	Point 2	Point 3	Point 4	Point 5	Point 6	Point 7	Point 8	Point 9	Point 10	Point 11	Point 12	Point 13	Point 14
D	R	S	6	1	-	A	D	A	0	8	1	9	2

¹ Please order programming tool separately (see accessories page 18)

Through hollow shaft collets		
Type	Part no.	Shaft diameter
SPZ-006-AD-D	2029192	6 mm
SPZ-1E4-AD-D	2029193	1/4"
SPZ-008-AD-D	2029194	8 mm
SPZ-3E8-AD-D	2029195	3/8"
SPZ-010-AD-D	2029196	10 mm
SPZ-012-AD-D	2029197	12 mm
SPZ-1E2-AD-D	2029198	1/2"

Dimensional drawings and order information

Programming Tool (USB version) for DRS61

Type	Part no.
PGT-05-S	1035342



Screw-in system M23, 12 pin

Cable connector M23 female, 12 pin, straight, screened

Type	Part no.	Contacts
DOS-2312-G	6027538	12

Cable connector M23, 12 pin, straight, screened

Type	Part no.	Contacts
STE-2312-G	6027537	12

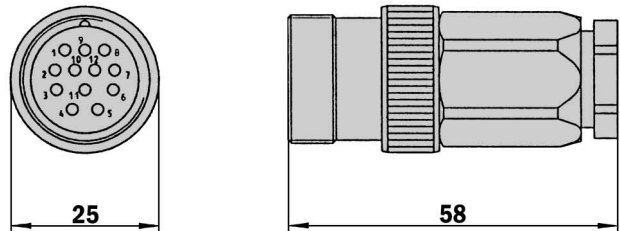
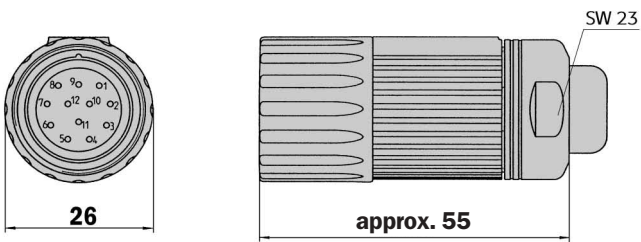

Connector M23 female, 12 pin, straight, cable 12 cores, 4 x 2 x 0.25 + 2 x 0.5 + 2 x 0.14 mm² with screening, capable of being dragged, cable diameter 7.8 mm

Type	Part no.	Contacts	Cable length
DOL-2312-G1M5MA3	2029212	12	1.5 m
DOL-2312-G03MMA3	2029213	12	3.0 m
DOL-2312-G05MMA3	2029214	12	5.0 m
DOL-2312-G10MMA3	2029215	12	10.0 m
DOL-2312-G20MMA3	2029216	12	20.0 m
DOL-2312-G30MMA3	2029217	12	30.0 m

Dimensional drawings and order information

Cable 8 core, per meter, 4 x 2 x 0.15 mm² with screening, cable diameter 5.6 mm

Type	Part no.	Wires
LTG-2308-MWENC	6027529	8

Cable 11 core, per meter, 4 x 2 x 0.25 + 2 x 0.5 + 1 x 0.14 mm² with screening, cable diameter 7.5 mm

Type	Part no.	Wires
LTG-2411-MW	6027530	11

Cable 12 core, per meter, 4 x 2 x 0.25 + 2 x 0.5 + 2 x 0.14 mm² with screening, capable of being dragged, cable diameter 7.8 mm

Type	Part no.	Wires	Explanation
LTG-2512-MW	6027531	12	
LTG-2612-MW	6028516	12	UV and salt water resistant

Couplings

Bellows coupling, max. shaft offset radial ± 0.3 mm, axial 0.4 mm, angle ± 4 degrees, torsion spring stiffness 120 Nm/rad, bellows of stainless steel, hubs of aluminium

Type	Part no.	Shaft diameter
KUP-0606-B	5312981	6 mm ... 6 mm
KUP-0610-B	5312982	6 mm ... 10 mm
KUP-1010-B	5312983	10 mm ... 10 mm
KUP-1012-B	5312984	10 mm ... 12 mm

Cheese-head screw
M2,5x8 DIN912 A2

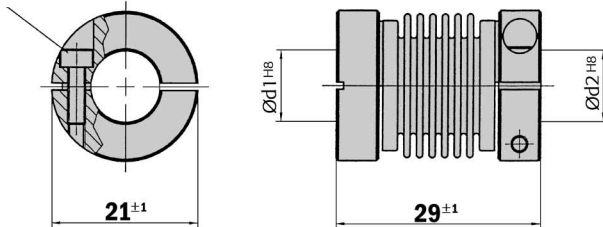

Spring-disc coupling, max. shaft offset radial ± 0.3 mm, axial 0.4 mm, angle ± 2.5 degrees, torsion spring stiffness 50 Nm/rad, flange of aluminium, spring-discs of glass-fibre-reinforced plastic

Type	Part no.	Shaft diameter
KUP-0610-F	5312985	6 mm ... 10 mm
KUP-1010-F	5312986	10 mm ... 10 mm

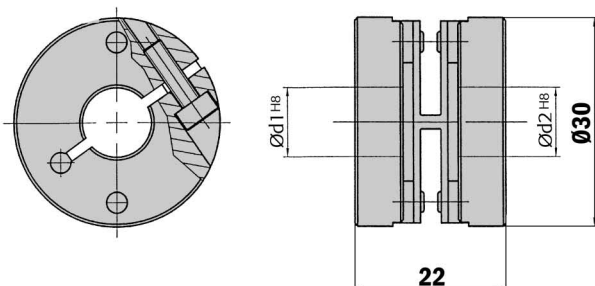

General tolerances according to DIN ISO 2768-mk

Dimensional drawings and order information

Mechanical Adaptors

Mounting bell incl. fixing set for encoder with servo flange

Type	Part no.	Flange spigot
BEF-MG-50	5312987	Diameter 50 mm

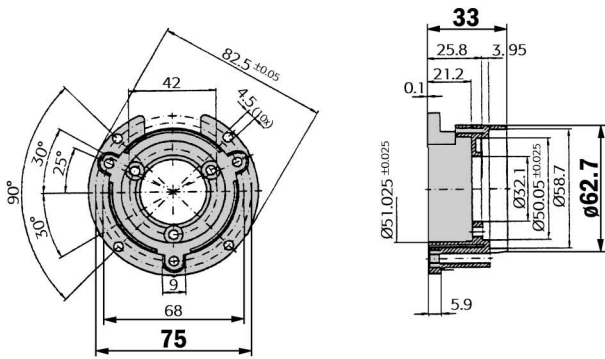

Mounting angle incl. fixing set for encoder with face mount flange

Type	Part no.	Flange spigot
BEF-WF-36	2029164	Diameter 36 mm

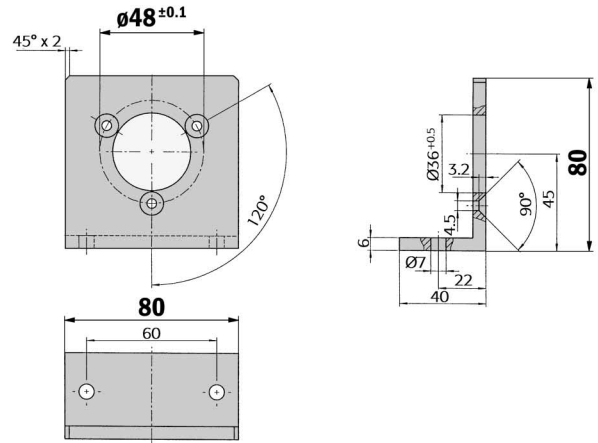

Servo clamps half ring, Set (comprises 2 pieces) for servo flanges with spigot diameter 50 mm

Type	Part no.
BEF-WG-SF050	2029165

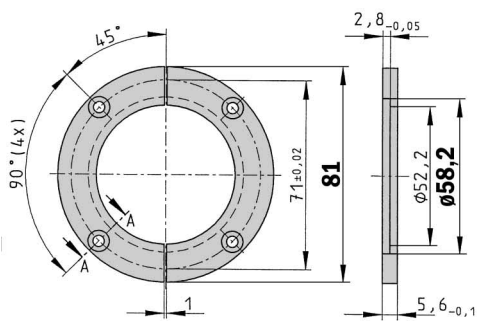

Servo clamps small, Set (comprises 3 pieces) for servo flanges

Type	Part no.
BEF-WK-SF	2029166

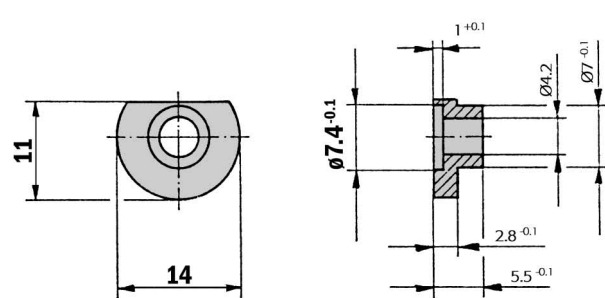

Dimensional drawings and order information

Mechanical Adaptors

Measuring wheel for encoder shafts with diameter 10 mm, type material plastic (Hytrel), wheel material plastic with aluminium hub

Type	Part no.	Circumference
BEF-MR-010020	5312988	0.2 m

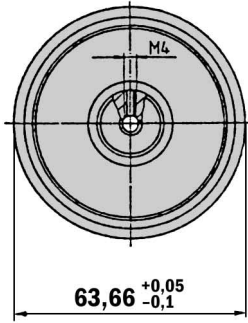

Measuring wheel for encoder shafts with diameter 10 mm, type material plastic (Hytrel), wheel material plastic with aluminium hub

Type	Part no.	Circumference
BEF-MR-010050	5312989	0.5 m

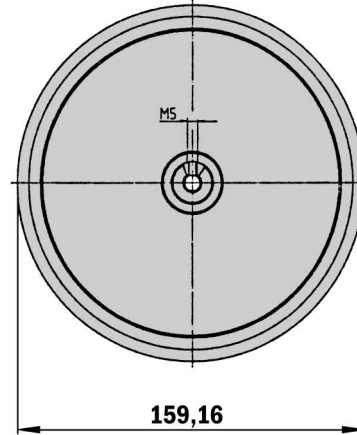

Collets

Collets for blind hollow shaft encoder

Type	Part no.	Shaft diameter
SPZ-006-AD-A	2029174	6 mm
SPZ-1E4-AD-A	2029175	1/4"
SPZ-008-AD-A	2029176	8 mm
SPZ-3E8-AD-A	2029177	3/8"
SPZ-010-AD-A	2029178	10 mm
SPZ-012-AD-A	2029179	12 mm
SPZ-1E2-AD-A	2029180	1/2"

Collets for through hollow shaft encoder

Type	Part no.	Shaft diameter
SPZ-006-AD-D	2029192	6 mm
SPZ-1E4-AD-D	2029193	1/4"
SPZ-008-AD-D	2029194	8 mm
SPZ-3E8-AD-D	2029195	3/8"
SPZ-010-AD-D	2029196	10 mm
SPZ-012-AD-D	2029197	12 mm
SPZ-1E2-AD-D	2029198	1/2"

Contact:

Australia

Phone +61 3 9497 4100
1800 33 48 02 – tollfree
E-Mail sales@sick.com.au

Belgium / Luxembourg

Phone +32 (0)2 466 55 66
E-Mail info@sick.be

Brasil

Phone +55 11 5091-4900
E-Mail sac@sick.com.br

Ceská Republika

Phone +420 2 57 91 18 50
E-Mail sick@sick.cz

China

Phone +852-2763 6966
E-Mail ghk@sick.com.hk

Danmark

Phone +45 45 82 64 00
E-Mail sick@sick.dk

Deutschland

Phone +49 (0)2 11 53 01-250
E-Mail info@sick.de

España

Phone +34 93 480 31 00
E-Mail info@sick.es

France

Phone +33 1 64 62 35 00
E-Mail info@sick.fr

Great Britain

Phone +44 (0)1727 831121
E-Mail info@sick.co.uk

India

Phone +91 (11)2696 7651
E-Mail ayograj@tecnovaglobal.com

Italia

Phone +39 011 79 79 65
E-Mail info@sick.it

Japan

Phone +81 (0)3 3358 1341
E-Mail info@sick.jp

Korea

Phone +82-2 786 6321/4
E-Mail kang@sickkorea.net

Netherlands

Phone +31 (0)30 229 25 44
E-Mail info@sick.nl

Norge

Phone +47 67 81 50 00
E-Mail austefjord@sick.no

Österreich

Phone +43 (0)22 36 62 28 8-0
E-Mail office@sick.at

Polska

Phone +48 22 837 40 50
E-Mail info@sick.pl

Republika Slovenija

Phone +386 (0)1-47 69 990
E-Mail selanm@sick.com

Russia

Phone +7 95 775 05 30
E-Mail info@sick-automation.ru

Schweiz

Phone +41 41 619 29 39
E-Mail contact@sick.ch

Singapore

Phone +65 6744 3732
E-Mail admin@sicksgp.com.sg

Suomi

Phone +358-9-25 15 800
E-Mail sick@sick.fi

Sverige

Phone +46 8 680 64 50
E-Mail info@sick.se

Türkiye

Phone +90 216 388 95 90 pbx
E-Mail info@sick.com.tr

Taiwan

Phone +886 2 2365-6292
E-Mail sickgrc@ms6.hinet.net

USA

Phone +1 937-454-1956
E-Mail sales@stegmann.com

More representatives and agencies
in all major industrial nations at
www.sick.com

SICK | STEGMANN

SICK AG • Industrial Sensors • Waldkirch • Germany • www.sick.com
SICK STEGMANN GmbH • Donaueschingen • Germany • www.sick-stegmann.de