

## Usage of the D6T-44L / D6T-8L Thermal sensor

--- Connection and Getting data ---

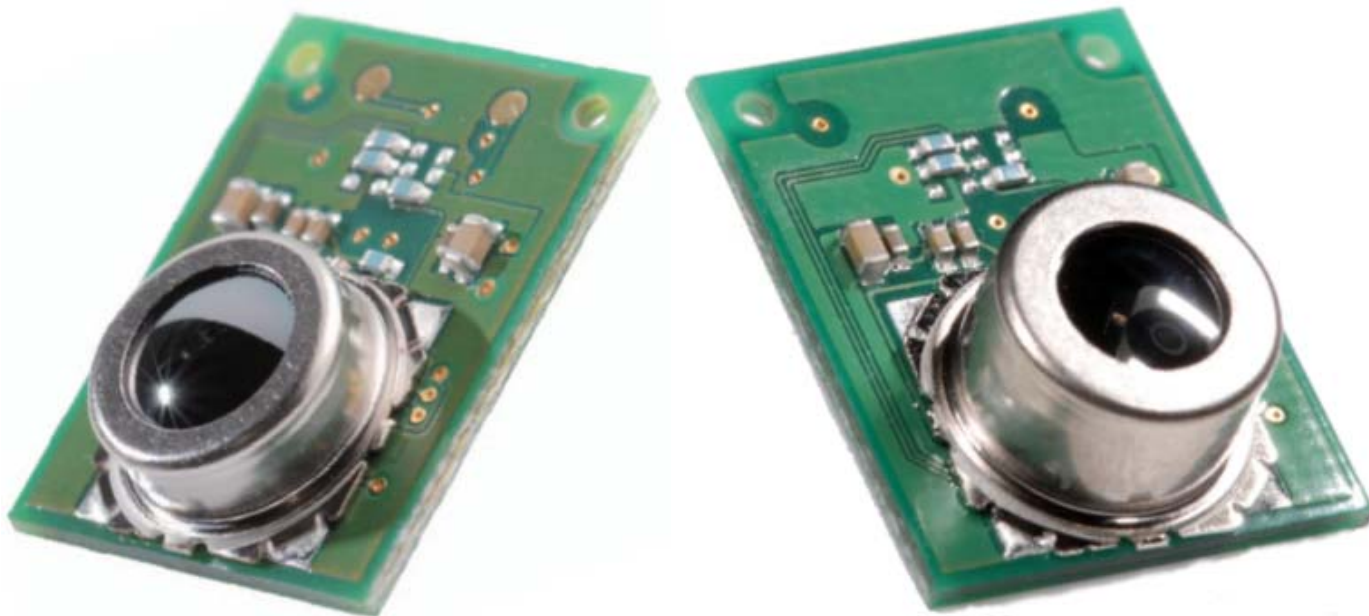

MDMK-12-0244

## Outer view

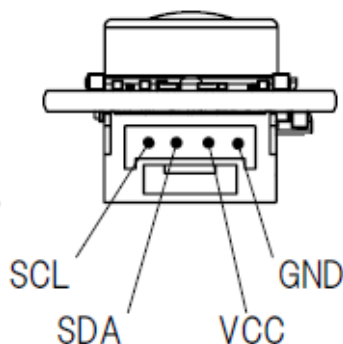
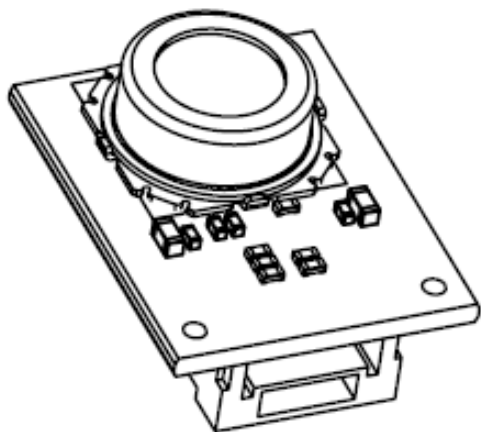

D6T-44L

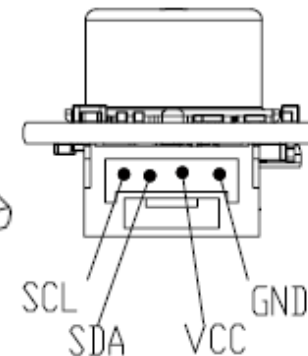
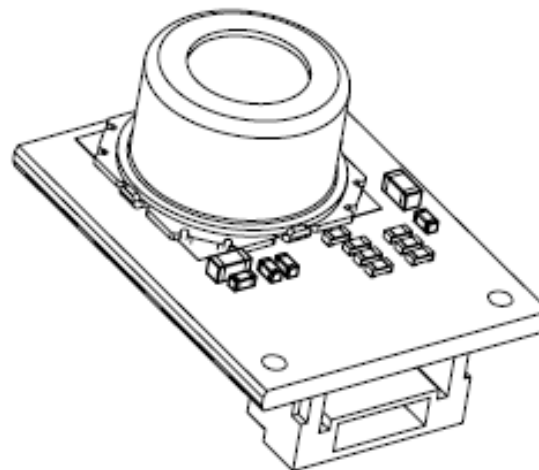

D6T-8L

Connector parts : SM04B-GHS-TB(JST)

## I/O pin

GND	ground
VCC	5V +/-10%
SDA	I2C(5V) Data line
SCL	I2C(5V) Clock line

## Connector [JST]

Contact parts : 4pcs  
SSH1-002T-P0.2

Housing parts :  
GHR-04V-S



## Electrical Connection 1

### Case1: 5V MCU (Direct)

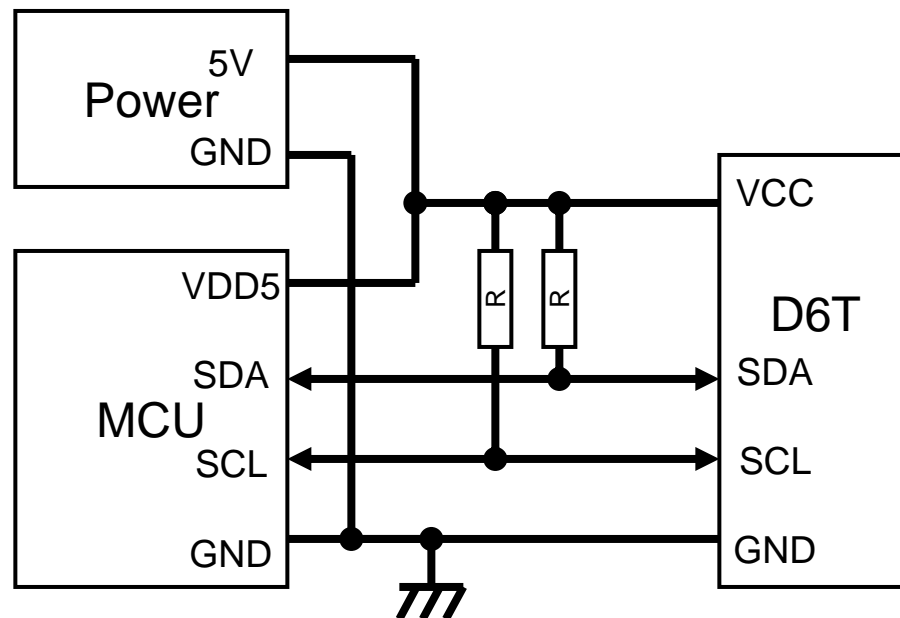

### Case2: 3V MCU (5V tolerant I2C port) Direct connect

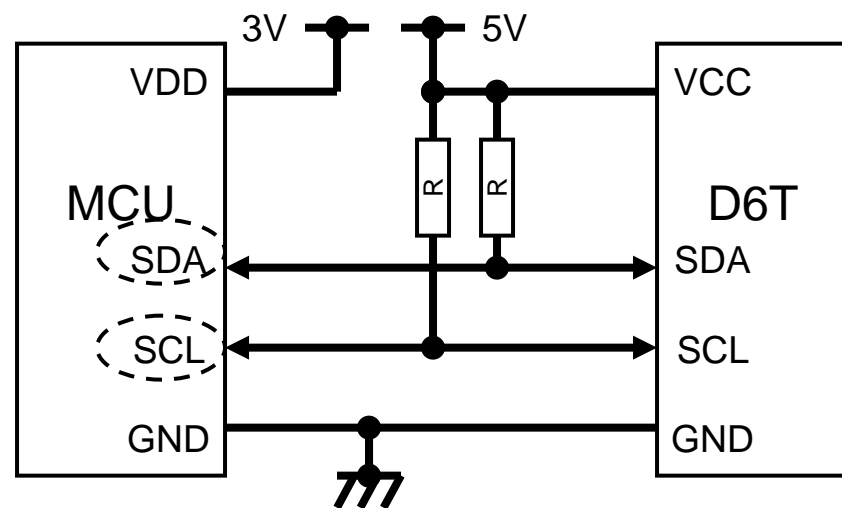

#### Pull-up Resister :

Impedance value is decided by user.  
(see I2C[100kHz] specification note.)  
(Most case : About 3k to 10k ohm)

## Electrical Connection 2

### Case3: Using I2C converter

(no 5V tolerant port)  
(other LV I2C device is exist)

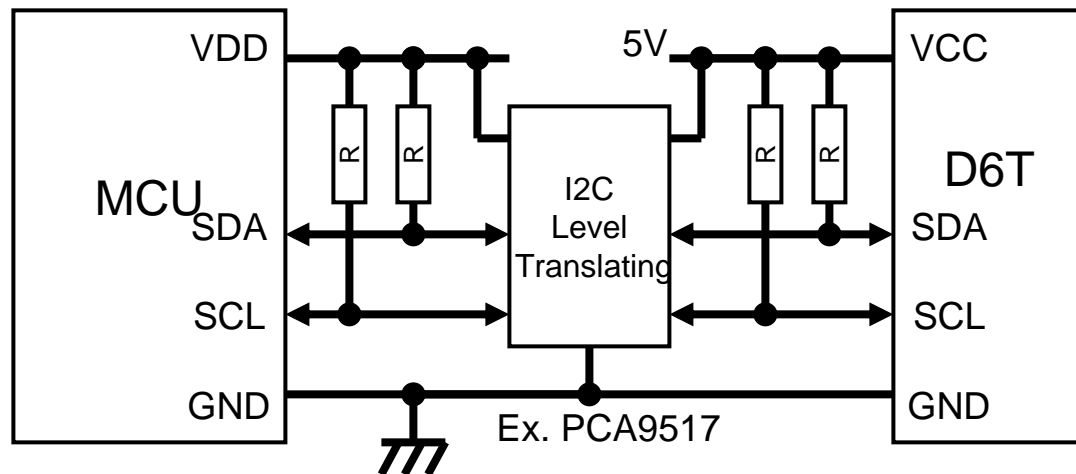

### Case4: Software I2C using Bi-directional Open Drain ports

(MCU have no inside I2C module)

Note. Wait routine for Clock-Stretching  
is required to prepare by user.

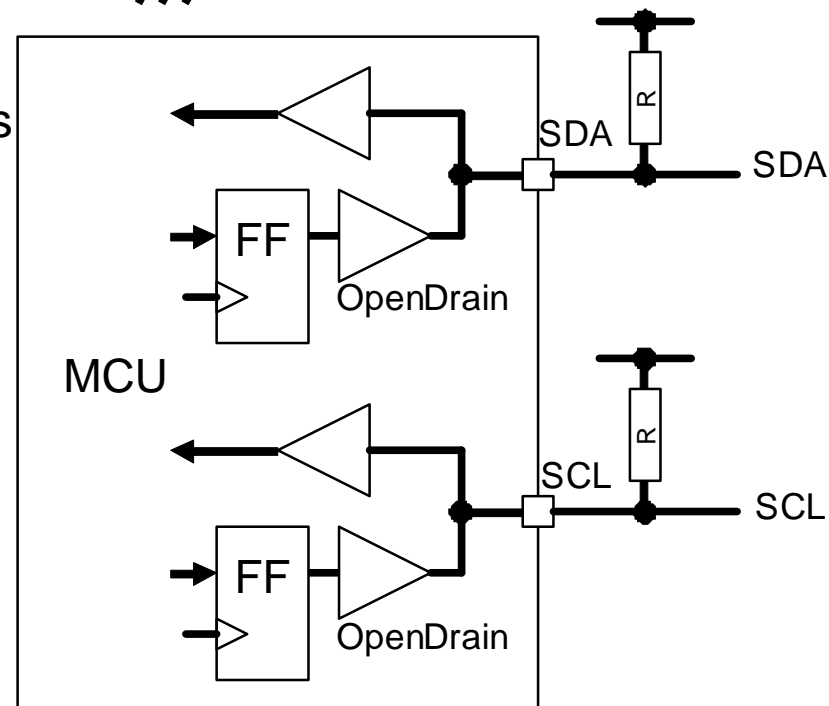

## Electrical Connection 3

Case5: Using I2C switch  
(multiple D6Tsensor)

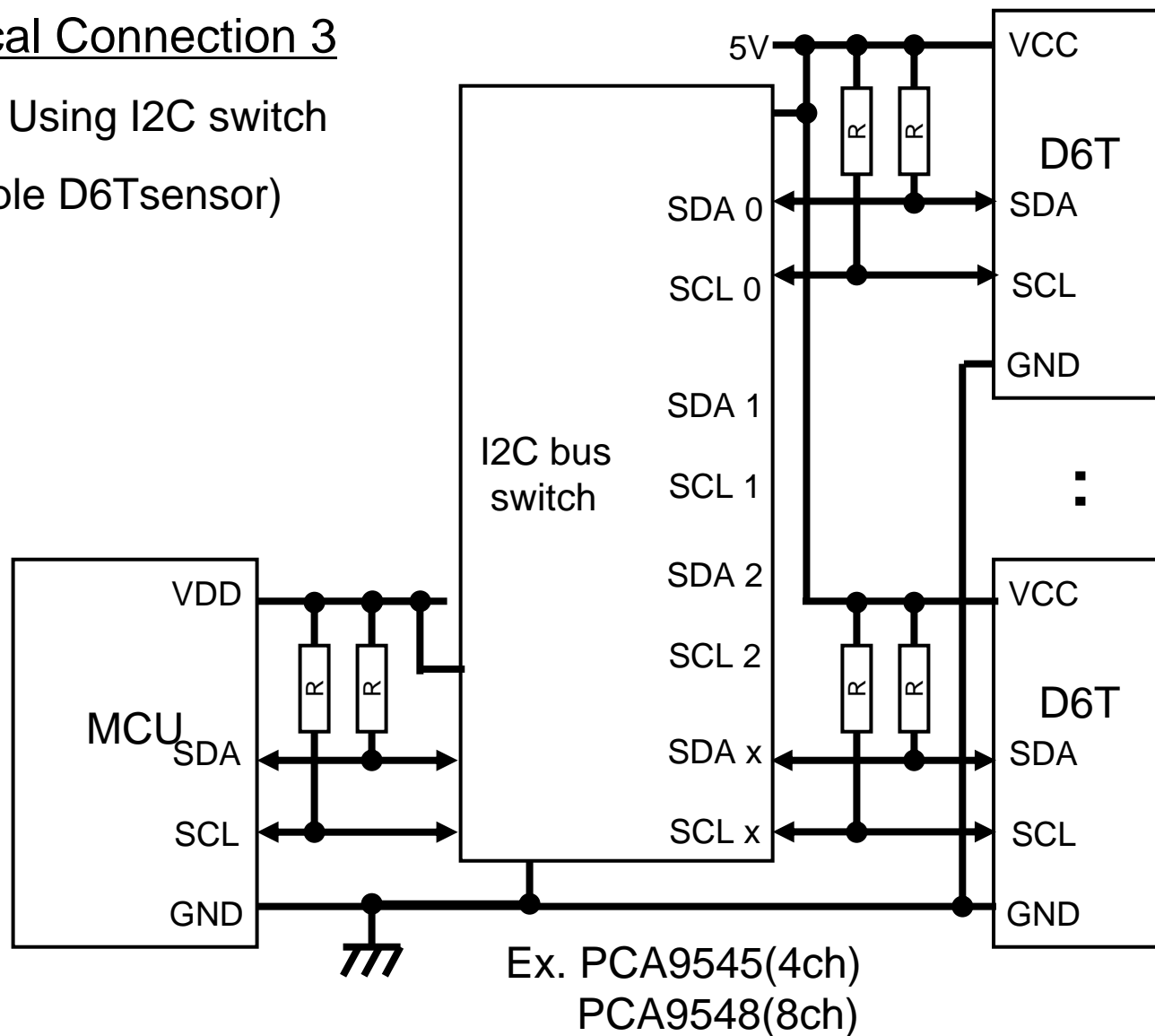

## I2C port condition setting

Device Address	7bit : 0001_010b
	8bit (with R/W bit) Read : 15h , Write : 14h
Data bit width	8bit (MSB-first)
Clock Frequency	max 100kHz
Control for Clock-stretching	On (Auto waiting)

## Port-data chart

### Case 16ch (D6T-44L)

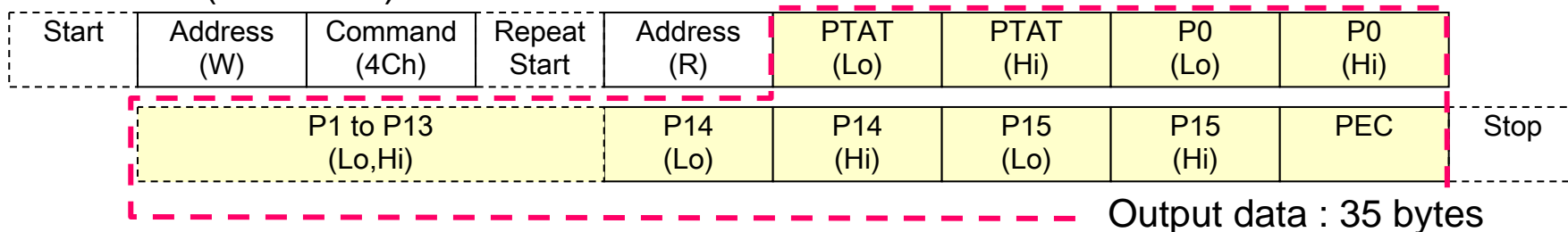

### Case 8ch (D6T-8L)

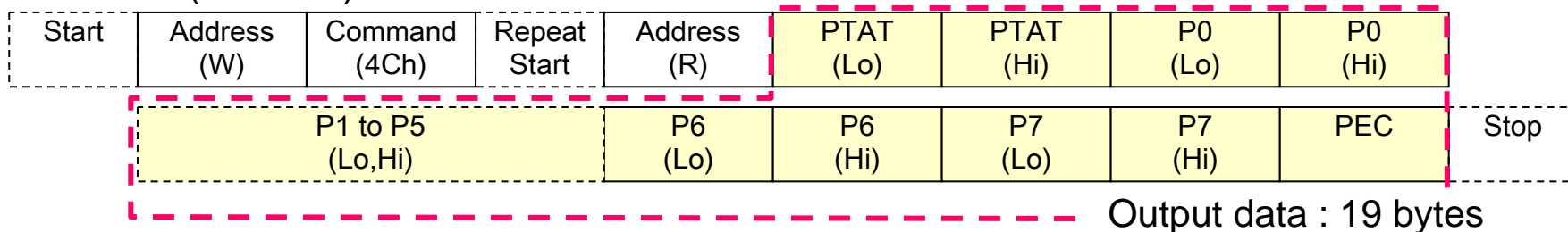

## Output Data Format

1. PTAT : It is the value of the reference temperature, inside the sensor module.

Temperature data ( PTAT & Pn ) is 16bit-width, signed, 10 times value of degC.  
Example : 12.7 degC = 007Fh(127) , 25.8 degC = 0102h(258)

2. P0 to P7(D6T-8L-06) , P0 to P15(D6T-44L-06)

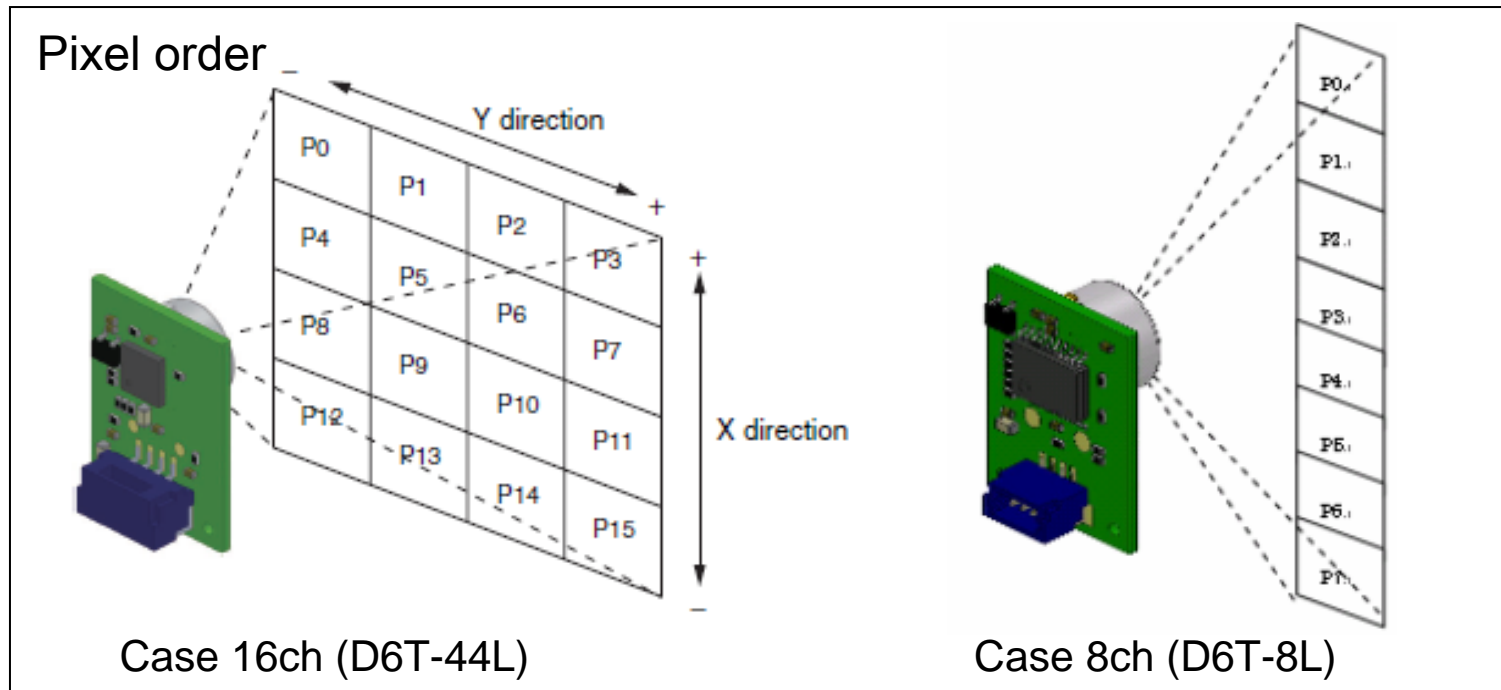

3. PEC : Packet error check code. Based on the “SM bus” specification.

## Signal chart

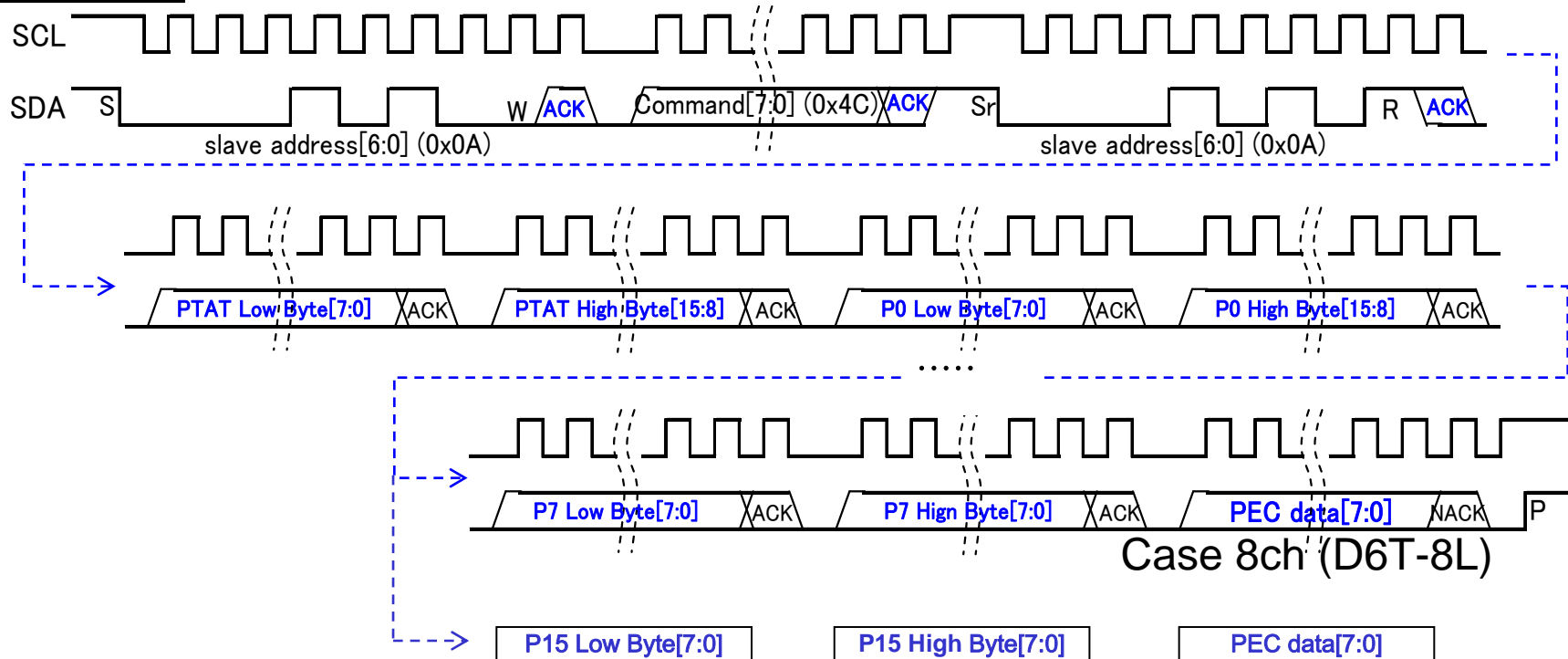

- “S” : Start Condition
- “Sr” : Repeat Start Condition
- “P” : Stop Condition
- “W/R” : Write (Lo) / Read (Hi)
- “ACK” : Acknowledge reply
- “NACK” : No-acknowledge reply

Case 8ch (D6T-8L)

Case 16ch (D6T-44L)



## Example Getting the measurement value. (1/2)

```
// I2C communication functions
extern void I2C_start(); // Send Start condition
extern void I2C_repeatstart(); // Send Repeat Start condition
extern void I2C_stop(); // Send Stop condition
extern void I2C_send1( char addr8 , char cmd ); // Send 1 byte
extern void I2C_getx( char addr8 , char buff[] , int length ); // Get n bytes
extern int D6T_checkPEC( char buf , int pPEC );
// Global var.
extern char readbuff[35];
extern int tPTAT;
extern int tP[16];
extern int tPEC;
```

```
int D6T_getvalue()
{
```

```
    I2C_start();
    I2C_send1( 0x14 , 0x4C ); // 14h = { 0Ah(Addr7) : Write(0b) }
```

**Case 16ch (D6T-44L)**

```
    I2C_repeatstart();
    I2C_getx( 0x15 , readbuff , 35 ); // 15h = { 0Ah(Addr7) : Read(1b) } , 35 = 2*(1+16)+1
```

```
    I2C_stop();
    If(!D6T_checkPEC(readbuff, 34)) {
        return -1; // error
    }
```

```
    tPTAT = 256*readbuff[1] + readbuff[0];
    tP[0] = 256*readbuff[3] + readbuff[2];
```

```
    tP[1] = 256*readbuff[5] + readbuff[4];
    tP[2] = 256*readbuff[7] + readbuff[6];
```

```
    tP[3] = 256*readbuff[9] + readbuff[8];
    tP[4] = 256*readbuff[11] + readbuff[10];
```

```
    tP[5] = 256*readbuff[13] + readbuff[12];
    tP[6] = 256*readbuff[15] + readbuff[14];
```

```
    I2C_getx( 0x15 , readbuff , 19 ); // 19 = 2*(1+8)+1
    I2C_stop();
    If(!D6T_checkPEC(readbuff, 18)) {
        return -1; // error
    }
```

**Case 8ch (D6T-8L)**

## Example Getting the measurement value. (2/2)

```

tP[7] = 256*readbuff[17] + readbuff[16];
tP[8] = 256*readbuff[19] + readbuff[18];
tP[9] = 256*readbuff[21] + readbuff[20];
tP[10] = 256*readbuff[23] + readbuff[22];
tP[11] = 256*readbuff[25] + readbuff[24];
tP[12] = 256*readbuff[27] + readbuff[26];
tP[13] = 256*readbuff[29] + readbuff[28];
tP[14] = 256*readbuff[31] + readbuff[30];
tP[15] = 256*readbuff[33] + readbuff[32];
tPEC = readbuff[34];
return 1;
}

```

```

measure()
{
    n = 0;
    do{
        status = D6T_getvalue();
        n++;
    }while(status < 0 && n < LOOPLIMIT);
    if(status < 0){
        // error operation.
    }
    printf( "%d, %d, %d, %d, %d, %d, %d, %d, %d, %d, %d, %d, %d, %d, %d, %d, %d, %d, %d , %d¥n" ,
        tPTAT, tP[0], tP[1], tP[2], tP[3], tP[4], tP[5], tP[6], tP[7],
        tP[8], tP[9], tP[10], tP[11], tP[12], tP[13], tP[14], tP[15], tPEC);
}

```

```

tP[7] = 256*readbuff[17] + readbuff[16];
tPEC = readbuff[18];
return 1;
}

```

Case 8ch (D6T-8L)

Case 16ch (D6T-44L)

### Output Example

```

223 , 224, 224, 273, 335, 239, 221, 240, 297 , 264, 232, 221, 254, 299, 258, 229, 233 , 80
223 , 271, 261, 265, 304, 284, 270, 264, 274 , 302, 285, 271, 260, 319, 304, 286, 269 , 193
223 , 296, 273, 285, 311, 306, 291, 281, 301 , 311, 310, 293, 296, 312, 322, 311, 302 , 83

```

Case 16ch (D6T-44L)  
PTAT , 16 data , PEC

## Example PEC check routine

Using PEC value, user can check data validity. (see SMBus specification).

```
unsigned char  calc_crc( unsigned char  data )
{
    int  index;
    unsigned char  temp;

    for(index=0;index<8;index++){
        temp = data;
        data <<= 1;
        if(temp & 0x80) data ^= 0x07;
    }
    return data;
}
```

```
int  D6T_checkPEC( char buf , int pPEC );
{
    unsigned char  crc;
    int  i;

    crc = calc_crc( 0x14 );
    crc = calc_crc( 0x4C ^ crc );
    crc = calc_crc( 0x15 ^ crc );
    for(i=0;i<pPEC;i++){
        crc = calc_crc( readbuff[i] ^ crc );
    }
    return (crc == readbuff[pPEC]);
}
```

```
int  D6T_checkPEC( char buf , int pPEC );
{
    unsigned char  crc;
    int  i;

    crc = calc_crc( 0x15 );
    for(i=0;i<pPEC;i++){
        crc = calc_crc( readbuff[i] ^ crc );
    }
    return (crc == readbuff[pPEC]);
}
```

**Case A : Repeat Start Condition**

**Case B : Start Condition (after stopped)**

# Application Note [D6T FAQ Usage]

Example Detect routine of wait status (Clock-stretching)  
For Software-I2C using Bidirectional OpenDrain ports

Wait request from Slave(Sensor) to Master(MCU).

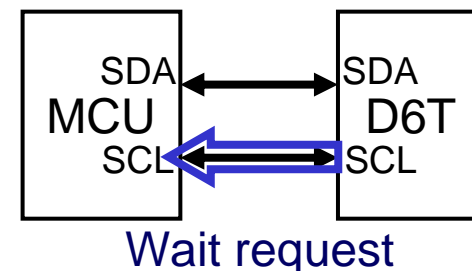

Master	Slave (Sensor)
a) SCL drive to Lo for Ack.	Checking SCL status.(Lo)
c) SCL output change to Hi-Z. SCL I/O mode change to Input	b) SCL drive to Lo for Wait. Wait ...
d) Checking SCL status.(Hi) Checking ...	Wait finish
f) Finish Detected.	e) SCL output change to Hi-Z.
g) Next operation.	

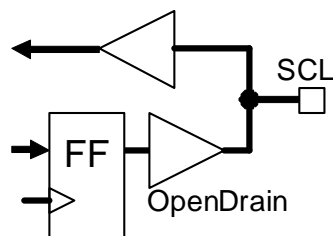

Bi-directional OpenDrain ports

