



USER MANUAL



UNIVERSAL TRANSDUCER

AR593



CE

*Thank you for choosing our product.
This user manual will tell you how to use the transducer in a correct and safe way.
Please read it carefully before installing the transducer.
If you have any questions, please contact our technical department.*

CONTENTS

1.	SAFETY PRECAUTIONS	2
2.	INSTALLATION INSTRUCTIONS	2
3.	TRANSDUCER CHARACTERISTICS	2
4.	TECHNICAL SPECIFICATIONS	3
5.	INSTALLATION DETAILS AND HOUSING DIMENSIONS	4
6.	CLAMP RAIL AND ELECTRICAL CONNECTORS DESCRIPTION	5
7.	FRONT PANEL DESCRIPTION	5
8.	CONFIGURATION PARAMETERS PROGRAMMING	6
9.	OUTPUT CONFIGURATION	7
10.	MEASUREMENT ERRORS INDICATION	8
11.	OWN NOTES	8

1. SAFETY PRECAUTIONS

- **Please read this user manual carefully before using the transducer.**
- To avoid instrument damage, check if all connections are correct before turning on the transducer.
- Use the transducer in appropriate conditions only (supply voltage, humidity and temperature).
- Before making any changes in electrical connections, please turn off power supply of the transducer.

2. INSTALLATION INSTRUCTIONS

This instrument has been designed to ensure the proper level of resistance to most noises, which can appear in industry environment. It is recommended to apply precautions listed below while working in environment where the level of disturbance is unknown:

- Do not connect the transducer to the same line with other high power devices without appropriate line filters.
- Use shielded power supply cables, sensor cables and signal cables. Shield grounding should be on one side of the cable, as close to the instrument as possible.
- Avoid placing measurement (signal) cables close to and in parallel with power cables.
- It's recommended to twist signal cables in pairs.
- Use cables with the same parameters for resistance sensors with 3 wire connection.
- Avoid placing transducer close to remotely controlled devices, electromagnetic meters, high power loads, loads with phase or common power regulation and other devices with high pulse noises.
- Connect metal rails with devices to ground or zero wire.

3. TRANSDUCER CHARACTERISTICS

- Linear transformation of measured temperature or other signal to current or voltage signal.
- Universal input:
 - Thermo-resistance.....Pt100, Ni100
 - Thermocouple.....J, K, S, B, R, T
 - Analog.....0/4÷20mA, 0÷10V, 0÷60mV, resistance
- Two independent outputs (current 0/4÷20mA and voltage 0÷10V, measurement retransmission or programmable alarm)
- Triple galvanic isolation (input / output / supply)
- Slim housing for TS35 (DIN) rail installation
- Transformation range, input type and other parameters configurable with AR950 programmer or AR955 programmer set.
- Programmed alarms for preset value exceeding with hysteresis.
- LED indication for transformation range exceeding, sensor error or alarm output status (on – off type).
- High accuracy and noise resistance.

4. TECHNICAL SPECIFICATIONS

Universal input (programmable), full measurement range:

RTD:	- Pt100 (3 or 2 wires).....	-200 ÷ 850°C (input default value)
	- Ni100 (3 or 2 wires).....	-50 ÷ 170°C
Thermocouple:	- J type.....	0 ÷ 800°C
	- K type.....	0 ÷ 1200°C
	- S type.....	0 ÷ 1600°C
	- B type.....	300 ÷ 1800°C
	- R type.....	0 ÷ 1600°C
	- T type.....	0 ÷ 350°C
	- Electronic temperature compensation for cold thermocouple ends	
Analog:	- current (Rwe = 110Ω).....	0 ÷ 20mA, 4÷20mA
	- voltage (Rwe = 100kΩ).....	0 ÷ 10V
	- voltage (Rwe > 5MΩ).....	0 ÷ 60mV
	- resistance.....	0 ÷ 1000Ω
Allowed leads resistance for resistance inputs (RTD, 0÷1kΩ).....		Rd < 30Ω (3 wires, for each wire)
Resistance input current (RTD, 0÷1kΩ).....		~250µA
Transformation ranges (2 independent).....		0 ÷ 500°C (programmed within input measurement range)
Outputs (programmable)		
	- current.....	0/4÷20mA, 20÷4/0mA
	- load resistance.....	Ro ≤ 500Ω
	- resolution.....	2.6µA
	- voltage.....	0÷10V, 10÷0V
	- load resistance.....	Rw > 2.5kΩ
	- resolution.....	1.3mV
Main transformation error (25°C).....		≤0.1% of full input measurement range ± 1 transformation range step
Additional error for thermocouple inputs		<2°C (cold ends temperature)
Additional error from temperature changes		≤0.01% of transformation range/°C
Temperature measurement resolution		0.1°C
Response time (10÷90%).....		360ms, programmed with 1 FILE parameter from 240 to 1600ms
Power supply		24V AC/DC (18÷50V DC, 14÷35V AC)
- power consumption.....		< 850mW

Isolation (input/output/supply)	1.5kV, 50Hz, 1min
Error indication	Red LED (A1, A2) and output signals (3.8mA(1), 21mA(1), 21.25mA(2), 10.625V(3))
Operating temperature	0 ÷ 65°C
Relative humidity range	0 ÷ 90% RH (non condensed)
Protection class	IP20
Working position	Any
Weight	~95g
Electromagnetic compatibility (EMC)	
- resistance : according to PN-EN 61000-6-2:2002(U)	
- emissivity : according to PN-EN 61000-6-4:2002(U)	
Transmission parameters for AR955 programmer..	2400bit/s, address MODBUS=1

Notes:

- (1) – for 4 ÷ 20mA output
- (2) – for 0 ÷ 20mA output
- (3) – for 0 ÷ 10V output

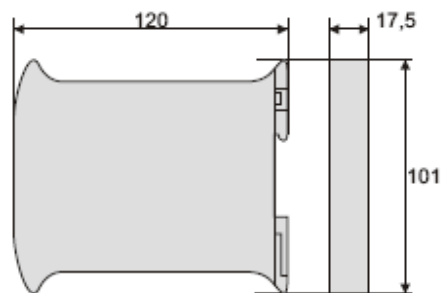

5. INSTALLATION DETAILS AND HOUSING DIMENSIONS

Dimensions	17.5 x 120 x 101mm
Installation	On TS35 (DIN EN 50022-35) rail
Material	Polycarbonate, ABS UL 94V-0

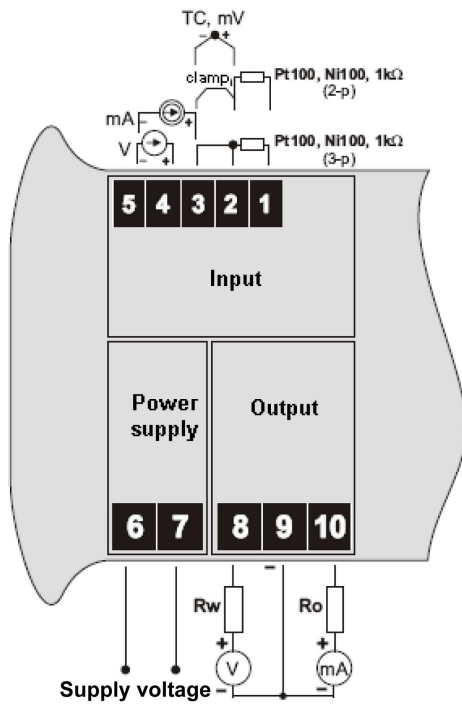

6. CLAMP RAIL AND ELECTRICAL CONNECTORS DESCRIPTION



Clamps	Description
1-2-3	Pt100, Ni100 input, resistance 0÷1kΩ (2 and 3 wires)
2-3	Thermocouple TC (J, K, S, B, R, T) and voltage (0÷60mV) input
3-5	Current input (0/4÷20mA)
4-5	Voltage input (0÷10V)
6-7	Power supply input (24V AC/DC)
8-9	Analog output 1 (0÷10V)
9-10	Analog output 2 (0/4 ÷ 20mA)
Ro, Rw	Measurement instrument load resistances
	Milliammeter
	Voltmeter

7. FRONT PANEL DESCRIPTION



AR593

Item	Description
PR	Programming socket
A1	LED indication for transformation range exceeding, sensor error or alarm output status (on – off type) for output 1 (0÷10V)
A2	LED indication for transformation range exceeding, sensor error or alarm output status (on – off type) for output 2 (0/4÷20mA)



CAUTION:

Connecting instruments other than AR950 programmer or AR955 programmer to PR socket may cause damage to connected instrument and AR593 transducer.

8. CONFIGURATION PARAMETERS PROGRAMMING

- To set configuration parameters, perform steps below:
 - Turn on the transducer power supply,
 - Open the front transparent transducer cover,
 - Connect AR950 or AR955 programmer to PR socket (2400bit/s, address MODBUS=1)
 - Proceed according to the programmer user manual instructions.
- After turning the transducer on for the first time, LED indication for transformation range exceeding or sensor error may occur. This error can occur when the sensor is not connected or other than default sensor is connected – you should connect the correct sensor, the analog input or change the configuration setup.

Table 1. Configuration parameters

No.	Item	Param.	Parameter Value and Range	Factory	User	
0	inP	Input (sensor) type	RTD	0=Pt100, 1=Ni100	0=Pt100	
			Thermocouple	2=J, 3=K, 4=S, 5=B, 6=R, 7=T		
			Current	8=4÷20mA, 9=0÷20mA		
			Voltage	10=0÷10V, 11=0÷60mV		
			Resistance	12=0÷1000Ω		
1	FiLE	Filter level (3)	0÷10	4		
2	doE (2)	Display resolution	0=1°C, 1=0.1°C	1=0.1°C		
		or decimal point position (1)	0=0, 1=0.0, 2=0.00, 3=0.000			
3	Abot	Input scale beginning (1)	1999÷9999 (for 0mA, 4mA, 0V, 0Ω)	00		
4	Atop	Input scale end (1)	1999÷9999 (for 20mA, 10V, 60mV, 1000Ω)	5000		
5	out1	Output 1 characteristic (0÷10V), (see section 9)	0=measurement retransmission, 1=inversion (heating), 2=direct (cooling)	0		
6	SEt1	Output 1 alarm value (0÷10V)	Within input measurement range	500°C		
7	Hi	Output 1 hysteresis	00÷9999°C or 0÷9999 units (1)	10°C		
8	bot1	Output 1 scale beginning (for 0V)	Within input measurement range	00°C		
9	top1	Output 1 scale end (for 10V)	Within input measurement range	5000°C		
10	tyP2	Output 2 type (0/4÷20mA)	0=4÷20mA, 1=0÷20mA	0		
11	out2	Output 2 characteristic (0/4÷20mA), (see section 9)	0=measurement retransmission, 1=inversion (heating), 2=direct (cooling)	0		
12	SEt2	Output 2 alarm value (0/4÷20mA)	Within input measurement range	500°C		
13	Hi2	Output 2 hysteresis	00÷9999°C or 0÷9999 units (1)	10°C		
14	bot2	Output 2 scale beginning (for 0mA or 4mA)	Within input measurement range	00°C		

15	LoP2	Output 2 scale end (for 20mA)	Within input measurement range	5000°C	
16	ARLo	Zero shift	1000 ÷ 1000 °C or 1000 ÷ 1000 units (1)	00°C	
17	ARL0	Amplification	-85.0 ÷ 115.0%	100.0%	

Notes:

- (1) for analog inputs (mA, V, mV, Ω)
- (2) only for data displaying in the connected programmer (AR950, AR955),
- (3) for **FILt = 1** response time is about 0.24s, for **FILt = 10** response time is about 1.6s. Higher filtration level gives smoother measurement value and longer response time.

9. OUTPUT CONFIGURATION

Output characteristic type is set by parameter 5: **out1** (for output 0÷10V) and 11: **out2** (for output 0/4÷20mA), see section 8, table 1. In measurement retransmission mode, the output signal is proportional to the signal measured in the range set by parameter 8: **bot1**, 9: **top1**, 14: **bot2** and 15: **top2**. When parameter 5: **out1**, 11: **out2** equals **1** or **2** corresponding output is switched to the alarm mode with ON-OFF type. The alarm mode is controlled by parameter 6: **Set1**, 7: **H1**, 12: **Set2** and 13: **H2** and output status is indicated by A1 and A2 LED.

Independent operation of each output allows configuring two different transformation ranges, operation modes, alarm values and hysteresis.

Operating principle of analog outputs for each operation mode is shown below.

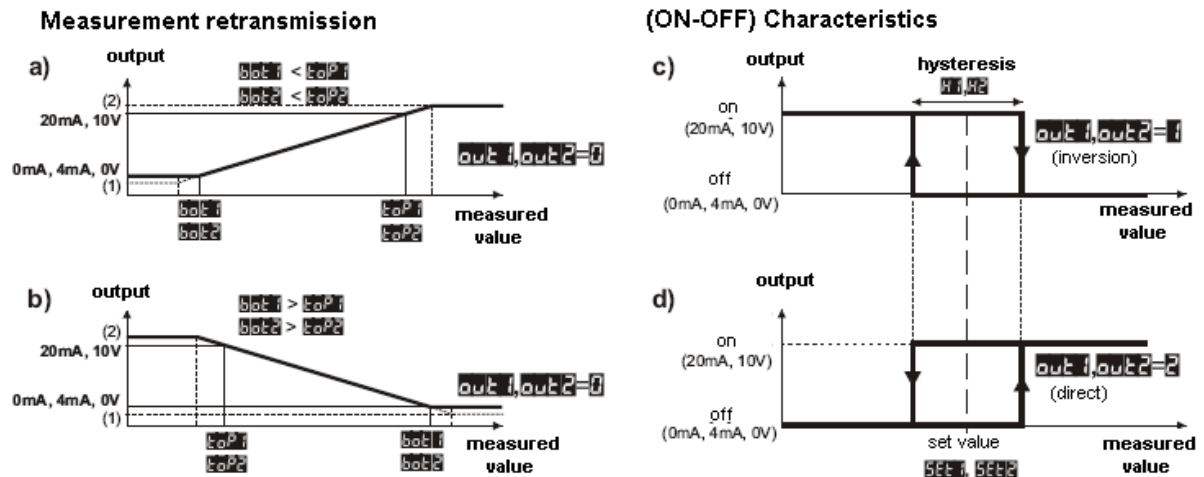

- (1) – 3.8mA – spreading from proportionality range bottom for output 4÷20mA
- (2) 21mA, 21.25mA, 10.625V – spreading from proportionality range top for outputs 4÷20mA, 0÷20mA and 0÷10V

Illustration (Analog output working characteristics):

- a) measurement retransmission – direct
- b) measurement retransmission – inverted

- c) alarm output – inverted
- d) alarm output – direct

10. MEASUREMENT ERROR INDICATION

Transducer indicates the following measurement errors:

- exceeding transformation range (up or down)
- connected sensor or input signal other than defined in configuration parameters
- sensor circuit malfunction

Measurement error indication:

- A1 or A2 LED blinking (only in the measurement retransmission mode)

11. OWN NOTES